



---

**Maestro Graphics  
System  
Version 3**

**Commissioning  
Manual**





# Maestro Graphics System Commissioning Manual

Document no. 1277

Issue 03

Published 10 January 2005

<b>ISSUE HISTORY</b>			
<b>Issue</b>	<b>Date</b>	<b>Version</b>	<b>Details</b>
1	01/04/2001	1.09	Maestro Commissioning manual 1st issue
2	01/10/2004		
3	10/01/2005		

# Maestro Graphics System Commissioning Manual

Document no. 1277

Issue 03

Published 10 January 2005

This document is copyright by Ziton, and all rights are reserved. It may not be photocopied, translated, or reduced to a machine readable form, in whole or in part, without the prior written consent of Ziton Ltd. It may not be distributed with changes or omissions, which have not been authorized by Ziton Ltd.

Although Ziton has reviewed and checked this documentation, and believes it to be accurate, Ziton gives no warranty or representation, either expressed or implied, with respect to accuracy, completeness, or errors.

For further information, please contact Customer Support at one of the following Ziton Centres.

---

Ziton Ltd  
8 Newmarket Court  
Chippenham Drive, Kingston  
Milton Keynes MK10 0AQ  
United Kingdom

Ziton (Pty) Ltd  
555 Voortrekker Road  
Maitland  
7405  
South Africa

Telephone: +44 (0)1908 281981  
Fax: +44 (0)1908 282554  
Email: [zitonuk@ziton.spx.com](mailto:zitonuk@ziton.spx.com)

Telephone: +27 (0)21 506 6000  
Fax: +27 (0)21 506 6050  
Email: [zitonsa@ziton.spx.com](mailto:zitonsa@ziton.spx.com)

---

# Maestro Graphics System

## Commissioning Manual

---

### Table of Contents

#### Introduction

1.1.	System overview .....	1
1.2.	System features .....	2
1.3.	Manual contents .....	3
1.4.	System architecture .....	3
1.5.	Workstation hardware specifications .....	4
1.6.	Workstation software specification.....	5
1.7.	Publications referred to in this guide.....	5

#### Installing the Maestro Package

2.1.	Introduction .....	1
2.2.	Preliminary operations - Windows 2000 .....	2
2.3.	Maestro installation - introduction .....	3
2.3.1.	Upgrade – using the restore option.....	3
2.3.2.	New installation .....	14
2.3.3.	Upgrade – using the install shield .....	22
2.4.	Changing default configurations and regional settings .....	27
2.5.	Dongle installation .....	27

#### Maestro Communications Interface

3.1.	Communications introduction and overview .....	1
3.1.1.	Accessing the communications interface .....	1
3.2.	Communication interface screens.....	1
3.3.	Communications screens toolbar functions .....	2
3.4.	Drop down menus .....	3
3.4.1.	File.....	3
3.4.2.	Comms .....	9
3.4.4.	Setup panels .....	21
3.5.	Diagnostic messages screen .....	23
3.6.	Panel configuration screen .....	24
3.6.1.	Fetch new panel data box .....	25
3.7.	Device analogs screen.....	26
3.7.1.	Fetch new analogue data box .....	28
3.8.	Device configuration screen.....	29
3.8.1.	Fetch new device data box .....	31
3.9.	Initial functional test.....	32
3.10.	Communications interface set up sequence .....	32
3.11.	Maestro Comms Planner Jobs.....	33

## Map Preparation

4.1.	Introduction .....	1
4.2.	Map structure .....	1
4.3.	Building zones .....	1
4.4.	Map levels .....	2
4.5.	Developing the map structure .....	4
4.6.	Drawing Maps .....	5
4.7.	Producing drawing files .....	7

## Maestro Database

5.1.	Introduction .....	1
5.1.1.	Accessing the database screens .....	1
5.2.	Tag database .....	3
5.2.1.	Tagging .....	3
5.2.2.	Tag database input screen .....	4
5.2.3.	Alarm state information .....	6
5.2.4.	Tag index list .....	8
5.2.5.	Navigation and editing toolbar .....	9
5.2.6.	Tag Creation Wizard .....	10
5.2.7.	Exit from the database .....	11
5.3.	Map database .....	12
5.3.1.	Map database input screen .....	13
5.3.2.	Map input .....	14
5.3.3.	Maps, icons and navigation buttons .....	16
5.3.4.	Map navigation and editing toolbar .....	25
5.3.5.	Commissioning Tools – grid setting .....	26
5.3.6.	Exit from the database .....	27
5.4.	Panel database .....	28
5.4.1.	Panel database input screen .....	28
5.4.2.	Panel controls input .....	29
5.4.3.	Exit from the database .....	31
5.5.	Icon database .....	32
5.5.1.	Icon database input screen .....	32
5.5.2.	Main icon screen .....	33
5.5.3.	Icon index .....	34
5.5.4.	Device property editor .....	35
5.5.5.	Zone property editor .....	38
5.5.6.	Custom icons .....	39
5.5.7.	Navigation and editing toolbar .....	41
5.5.8.	Exit from the database .....	42
5.6.	User database .....	42
5.6.1.	User database input screen .....	42
5.6.2.	User information .....	44
5.6.3.	Navigation toolbar .....	45
5.6.4.	Exit from the database .....	45
5.7.	Miscellaneous Settings .....	46
5.7.1.	Diagnostics tag edit .....	46
5.7.2.	Database input screen .....	47
5.7.3.	Exit from the database .....	51
5.8.	Database input sequence .....	52

**Setup**

6.1. Site set up and testing.....1  
6.1.1. Off site preparations.....1  
6.1.2. On site activity.....1  
6.1.3. Hardware connections .....2

**Maintenance**

7.1. System update and maintenance .....1

**Appendix A**

Appendix A1: Alarm state control code numbers .....1

**Appendix B**

Appendix B1: Preliminary operations - Windows NT .....1  
Appendix B2: Changing default configurations .....3  
Appendix B3: Windows regional settings .....4





# Maestro Graphics System Commissioning Manual

## Section 1 Introduction

UD1277.1  
Issue 3  
10/01/2005



# Maestro Graphics System

## Introduction

### 1.1. System overview

MAESTRO graphics system is a sophisticated software package providing comprehensive control and information interfaces for Ziton fire detection and alarm systems. Running on a computer workstation and interfacing directly to ZP fire detection systems, it provides the user with a central control facility, graphically displaying alarms and events.

The primary function of MAESTRO is system alarm management. In emergencies, individual alarms are usually easily handled, multiple alarms occurring simultaneously, or within short time periods are usually more difficult to assess. The immediate and correct handling of multiple alarms in fire situations can often be critical to both life safety and property loss.

MAESTRO simplifies the handling of multiple alarm situations, presenting information to the operator by clear, unambiguous maps and diagrams to enable fast and accurate decision making.

Alarms are graphically represented by maps. These are diagrams representing the floor areas and layouts of buildings, upon which the location and status of all devices connected to the fire alarm system are shown.

Alarms are brought to the attention of the MAESTRO operator both visually and audibly by means of an alarm banner display, prominently indicating the source of the alarm condition.

All devices throughout the building are represented on the map displays by icons, which change colour or appearance to indicate the precise sensor or callpoint originating the alarm or fault condition. Navigation tools provide rapid and easy movement through a variety of map structures, allowing the operator to handle multi alarm situations. A summary of all current alarms is displayed on screen at all times.

Complete ZP fire detection networks, can be controlled directly from the MAESTRO workstation, including the acceptance of active alarms, activating and silencing alarm sounders, panel resetting after fire events have been cleared and disabling and enabling individual devices.

All events and operator actions are saved to an event log, which can be viewed on screen and printed out to produce a range of event reports.

Users of the MAESTRO system are required to log on under password control. Passwords are task oriented and can be selected to suit individual operator responsibilities.

MAESTRO is simple to use and operate, providing comprehensive facilities for all aspects of fire detection and alarm system management.

# Maestro Graphics System

## Introduction

### 1.2. System features

#### What it does

The full list of facilities is extensive; therefore in this introduction only the main features have been included.

The primary function of the MAESTRO system is alarm management, displaying alarms and events in a manner that enables them to be processed and handled efficiently.

Alarms and system events are received from fire alarm and other systems and presented to the operator in order of importance, for appropriate action to be taken.

Events requiring action are treated as alarms and presented to the user visually, by means of an alarm banner display and audibly by an alert tone. The source of the alarm is confirmed by a text description and the device in alarm visually displayed on a map showing its exact location.

Information only events, demanding no immediate operator action are displayed and logged for future scrutiny if required. All events are saved to current and archive event log files, from where they can be printed out in a variety of report formats.

The main features of the MAESTRO system are as follows -

- Graphic alarm display by map, showing site, zone and device.
- Alarm banner with alert tone.
- Alarm lists showing all current alarms and events categorised by type.
- Information and handling instructions for each alarm.
- Ability to operate fire panels direct from the MAESTRO workstation.
- Disablement and enablement of sensors, sounders, zones direct from the MAESTRO workstation.
- View and operate controls on the panel fascia from the workstation screen.
- Four access groups with user defined authority for each operator.
- Historical archive of all events, unlimited length.
- Ability to produce reports by event type, time period or other parameters
- Event logbook allows the operator to record all actions taken.
- Built in telephone directory of emergency numbers.

# Maestro Graphics System

## Introduction

### 1.3. Manual contents

The publication is intended to provide the information necessary for fire alarm engineers and system designers to develop the databases required for MAESTRO systems of any size, set up and commission the communications between the fire detection and alarm panel and provide support services throughout the active life of the system.

The two major areas covered in detail are the development of the main database structures and the selection and installation of the communications interfaces between the fire alarm system and the MAESTRO workstation.

Guidelines are also included on the production of maps, which form the main visible element of the MAESTRO product and as such are most important both to operational efficiency and user acceptance.

All workstation screen displays, active menus and information windows are detailed. Users with a working knowledge of MS Windows 2000 or Windows NT, the ZP fire detection and alarm system and the particular site being protected should, with some patience, be able to complete a working MAESTRO system and subsequently provide all necessary maintenance support and site updates.

The sections in the document cover four main areas -

- Section 2** - outlines the method of installing the MAESTRO package onto the workstation computer.
- Section 3** - describes setting up the communications interface between the fire alarm system and the workstation.
- Section 4** - provides guidelines and suggestions for producing map structures.
- Section 5** - covers the MAESTRO databases.

Although references are made to multi workstations, client/server systems this guide is intended for sites featuring single MAESTRO workstations only.

Guidelines are also provided for ongoing system update and maintenance and the initial hand over to clients on site.

### 1.4. System architecture

The MAESTRO system is designed to be connected to ZP3 fire detection and alarm control panels, in systems of any size. The facilities are similar regardless of whether the workstation is supervising a single panel system, or forms the central control point of large, peer to peer networks connecting up to 64 control panels.

The MAESTRO workstation is seen within the network as another control panel. Full details of Z-NET Peer to Peer multi panel systems is provided in Publication UD 1160 Issue 1f, ZP3 Fire Detection and Alarm Control Panel.

Details of wiring connections between workstation and control panel are included in Section 6.1.3.

# Maestro Graphics System

## Introduction

### 1.5. Workstation hardware specifications

The MAESTRO main operating programme, its databases and communication interface must be run on PC workstation hardware of the following minimum specification.

- Intel Pentium Class Processor, 1 Ghz or higher
- Microsoft Windows 2000 Professional SP2
- 256Mb RAM (512Mb recommended).
- 32 Mb Graphics Card
- 10Gb Hard Drive (20Gb recommended)
- 1.44 Mb Floppy Drive
- PS2 Keyboard
- PS2 Mouse
- Sound Card
- 17inch Monitor, 0.2in pixel or better
- RS232 Port
- Parallel Printer Port
- PCI RS485 Card - required if connecting to ZP-NET or, Z6485 – ISA slot machine or,
- PCI Quatech 200/300 card (contact Ziton for availability)
- CD Rom Drive

#### Optional accessories

- CD Writer
- Sound Card and Speakers
- Dot Matrix Printer
- Inkjet or Laser Printer

# Maestro Graphics System

## Introduction

### 1.6. Workstation software specification

It is recommended that all new systems are run on workstations operating one of the following Windows service packs.

- i. Microsoft Windows NT4 SP5
- ii. Microsoft Windows 2000 Professional SP3
- iii. Microsoft Windows XP Professional SP1
- Screen resolution: 1024 x 768
- Screen colours: 256 or better

### 1.7. Publications referred to in this guide

The following publications are referred to in this guide.

1. **BS 5389 : Part 1 :1988.** British Standard Fire detection and alarm systems for buildings. Code of practice for system design, installation and servicing.
2. **EN54.** European Standard for fire detection and fire alarm systems.
3. **Ziton Publication UD 1160 Issue 01f.** ZP3 Fire detection and alarm control panel. Installation, operation and maintenance manual.
4. **Ziton Publication UD 1265 Issue 01.** MAESTRO graphics system. Users guide.
5. **Ziton Publication UD GA280 Issue 02.** ZCP2 Communications Protocol.





# Maestro Graphics System Commissioning Manual

## Section 2 Installing the Maestro Package

UD1277.2  
Issue 3  
10/01/2005



# Maestro Graphics System

## Installing the Maestro Package

### 2.1. Introduction

The MAESTRO software package is distributed in CD-ROM form including an Installation Utility. The files and utility, set up and install all the necessary data files, for a fully operational MAESTRO system.

The following section explains in detail the stages to follow to successfully install the MAESTRO package. Section 2.2 details stages to create a New User for workstations operating on Windows 2000. Section 2.3 covers the installation of a new MAESTRO system onto a workstation and Section 2.4 details upgrading of existing MAESTRO installations.

The instructions must be read in conjunction with the Installation Utility and it is assumed that the installer has the necessary knowledge to carry out the non-automatic operations. The operating system must already be successfully installed on the workstation machine.

# Maestro Graphics System

## Installing the Maestro Package

### 2.2. Preliminary operations - Windows 2000

This section details the sequence of operations, prior to installing the MAESTRO programme. For workstations running Windows NT, similar information is provided in Appendix B1.

1. Create a NEW USER, which will be the usual Windows 2000 Logon user.

Logon as "Administrator" with the appropriate password.

Select and Run : Start Menu / Administrative Tools (Common) / User Manager.

Select : User / New user.

Enter a new user name, e.g. "Operator". If this user is always required to logon to Windows 2000 with a Password, then enter the initial logon password.

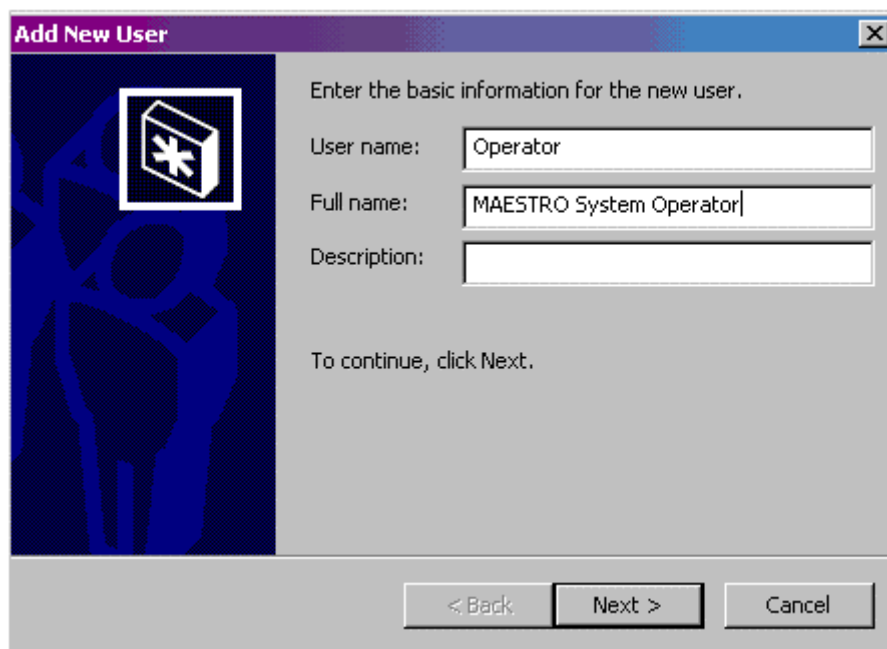

Set "User Must Change Password at Next Logon", "User Cannot Change Password", "Password Never Expires" and "Account Disabled" as required. The actual requirements for these settings will be determined by the policies enforced on each particular installation site.

Select : "Groups".

Confirm that the new user belongs only to the group "Users".

# Maestro Graphics System

## Installing the Maestro Package

2. Select : "Okay". (twice)

**Note - The creation of this user is only for the purpose of starting up the Windows 2000 workstation operating programme. The MAESTRO programme will then be started automatically. If this feature is not required, then special additional steps will need to be taken after MAESTRO has been installed.**

This user need not be the same user who will ultimately logon to the MAESTRO system.

3. Select : Start menu / Shut Down / Close all programs and logon as a different user.
4. Logon as "Operator", using the password which was specified in stage 1. (if any).

### 2.3. Maestro installation – introduction

There are 3 installation options:

1. Upgrade – using the restore option
2. New installation
3. Upgrade – using the install shield

Either option 1 or option 3 may be used when doing an upgrade. Option 1 is recommended when doing an upgrade on a PC which does not have Maestro installed.

#### 2.3.1. Upgrade – using the restore option

The peer-to-peer protocol caters for 64 panels. The user will have to configure how many panels are on the network.

Follow this procedure if you are upgrading from a previous version of Maestro.

1. **Backup** the current installation of Maestro
  - 1.1. Backup the current Maestro database using the Maestro backup facility. Proceed as follows.
  - 1.2. Navigate to File\backup (commissioning tools).

- 1.3. Backup the following Maestro databases:

- Tag Database
- Map Database
- Panel Database
- Icon Database
- User Database
- Network Database
- Settings Database
- Diagnostic Database
- Events Database

This procedure must be repeated for each database to be backed up.

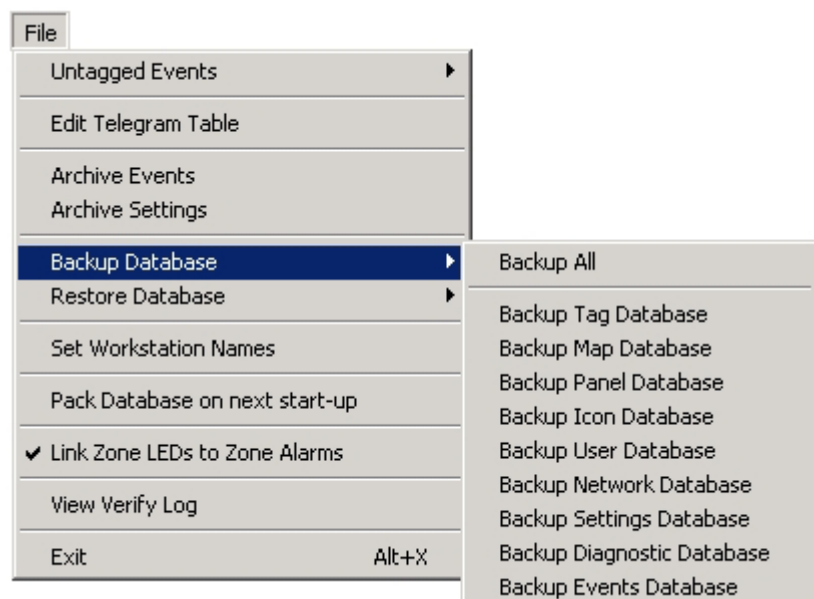

# Maestro Graphics System

## Installing the Maestro Package

- 1.4. Click on the OK button to confirm the backup path.

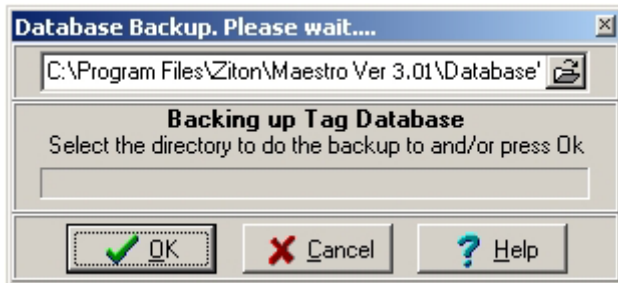

- 1.5. Click on the Yes button when prompted for confirmation. Repeat steps 1.2 to 1.5 for each database to be backed up.

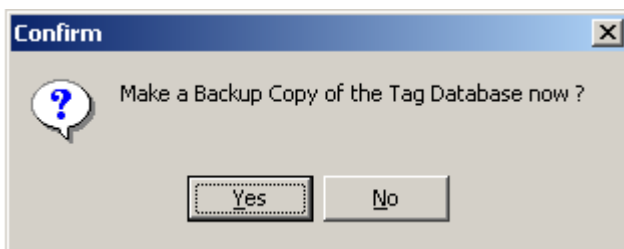

- 1.6. Using windows explorer, copy the maps to the map folder in the new installation directory structure.
2. Uninstall the current installation of Maestro using windows add/remove programs. Follow the on-screen prompts.
3. Installation wizard
- 3.1. Run setup.exe (Maestro installation CD) to launch the installation wizard.

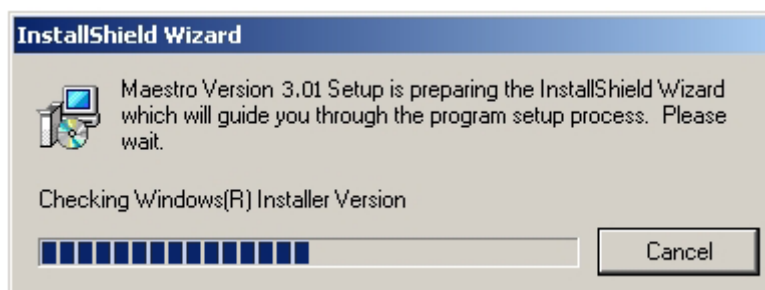

# Maestro Graphics System

## Installing the Maestro Package

3.2. Select "Install new Version" and follow the prompts.

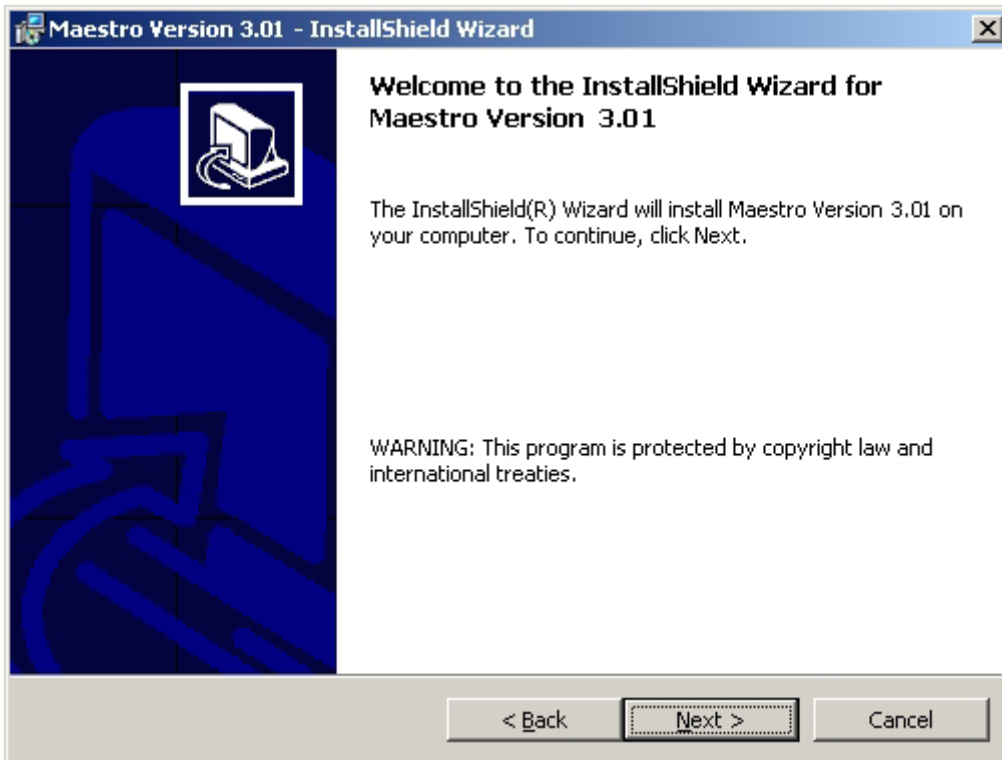
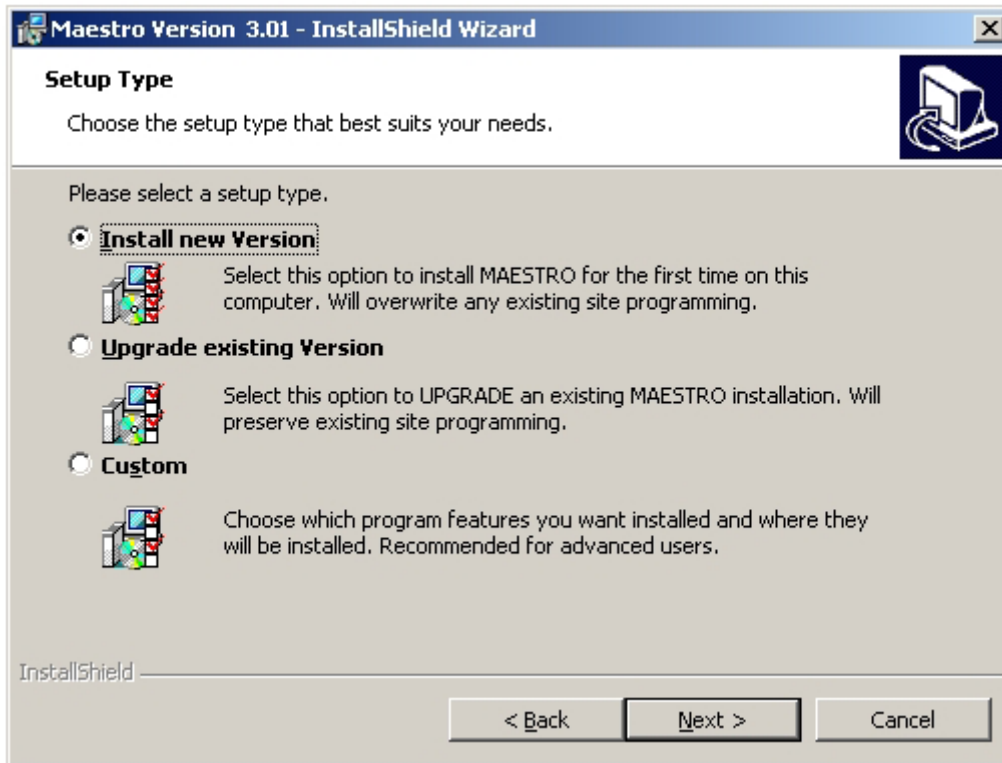

# Maestro Graphics System

## Installing the Maestro Package

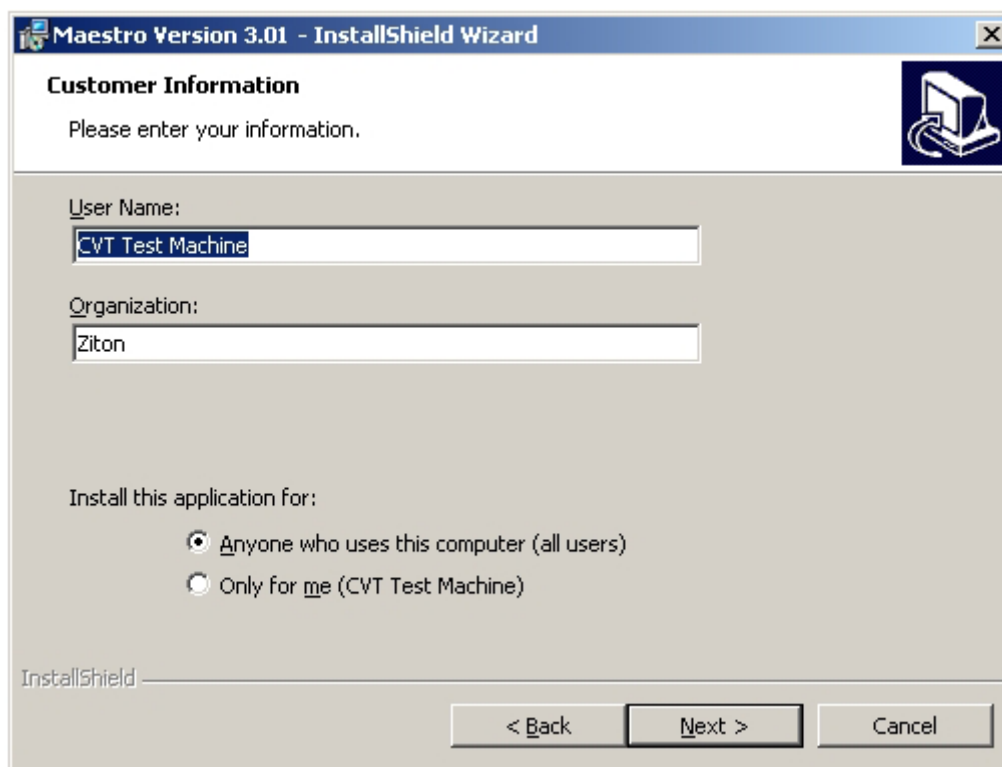

Note: The option for 'all users' is recommended.

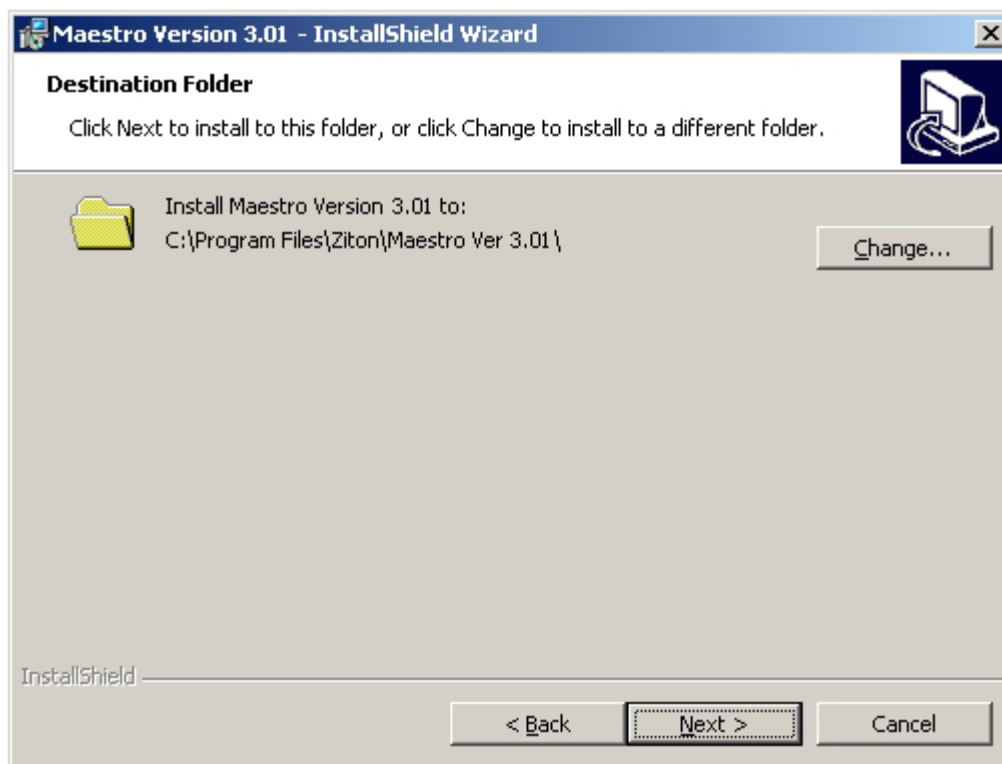



# Maestro Graphics System

## Installing the Maestro Package

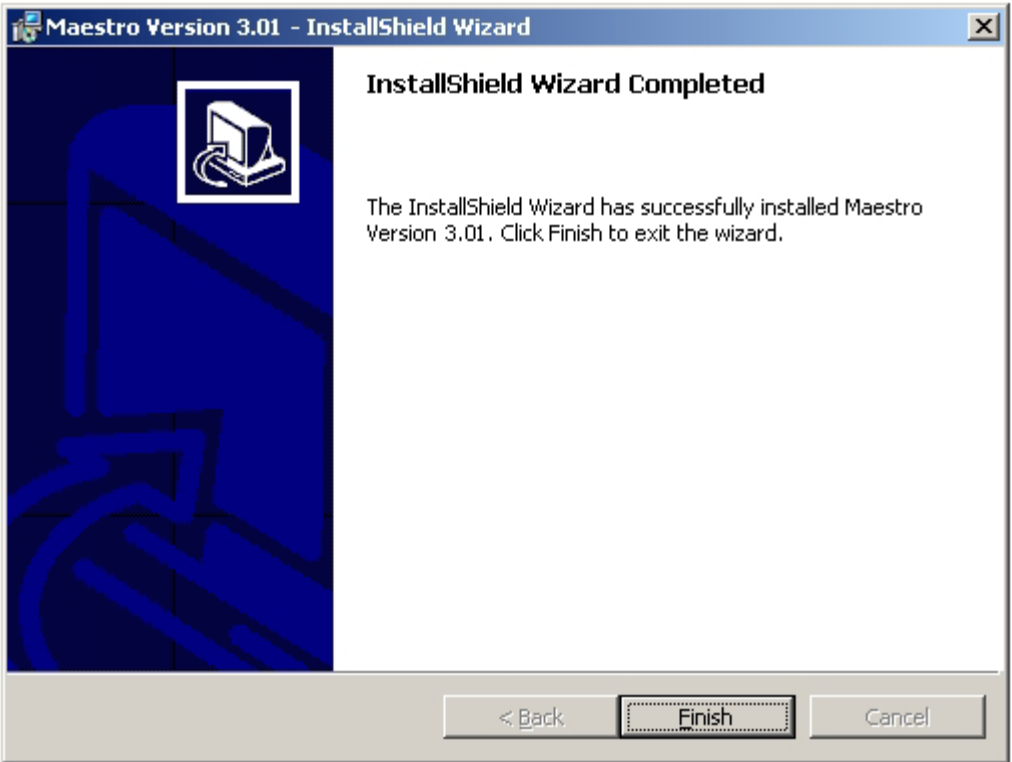
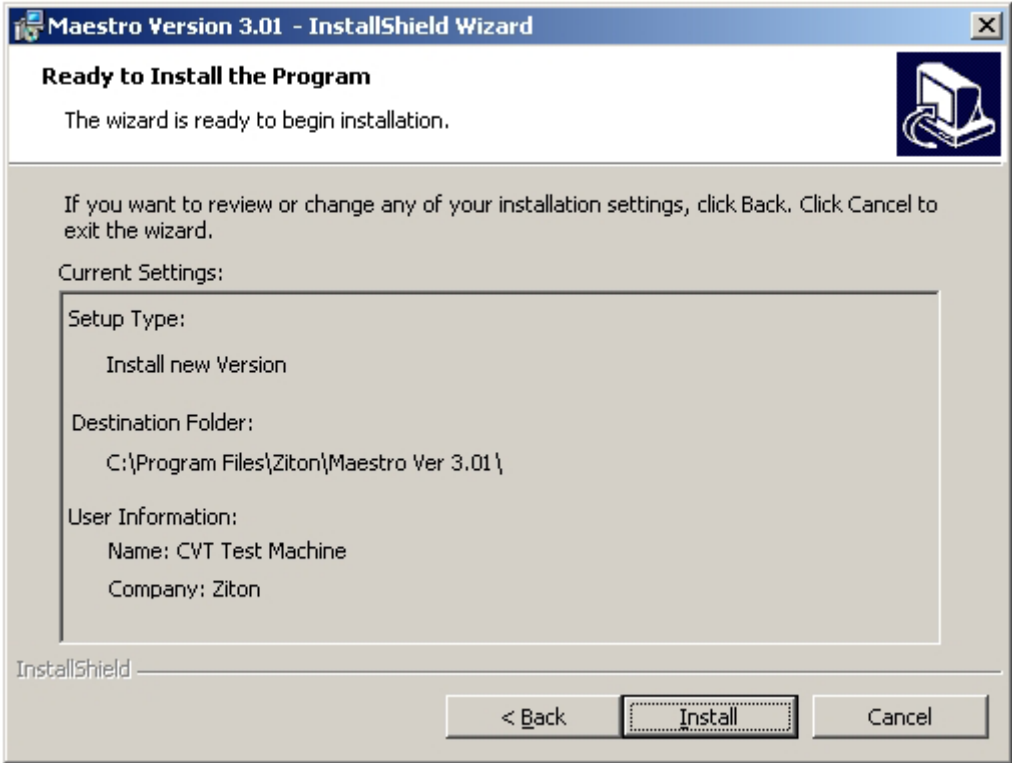

# Maestro Graphics System

## Installing the Maestro Package

4. Maestro Comms Setup. After the Install wizard setup is completed the comms settings must be configured. Two setup options are available.

### 4.1 Option 1 (recommended)

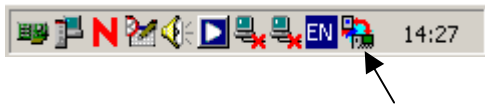

4.1.1 Open Maestro Comms by right clicking on the Maestro icon (bottom, right taskbar).

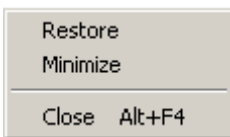

4.1.2. Select the restore option.

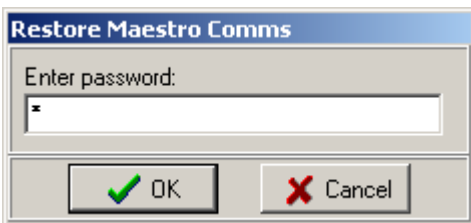

4.1.3. Enter the user password at the prompt. The initial password after installing Maestro is "install"

4.1.4. Click on Comms\Setup Communications to display the communication channels setup form.

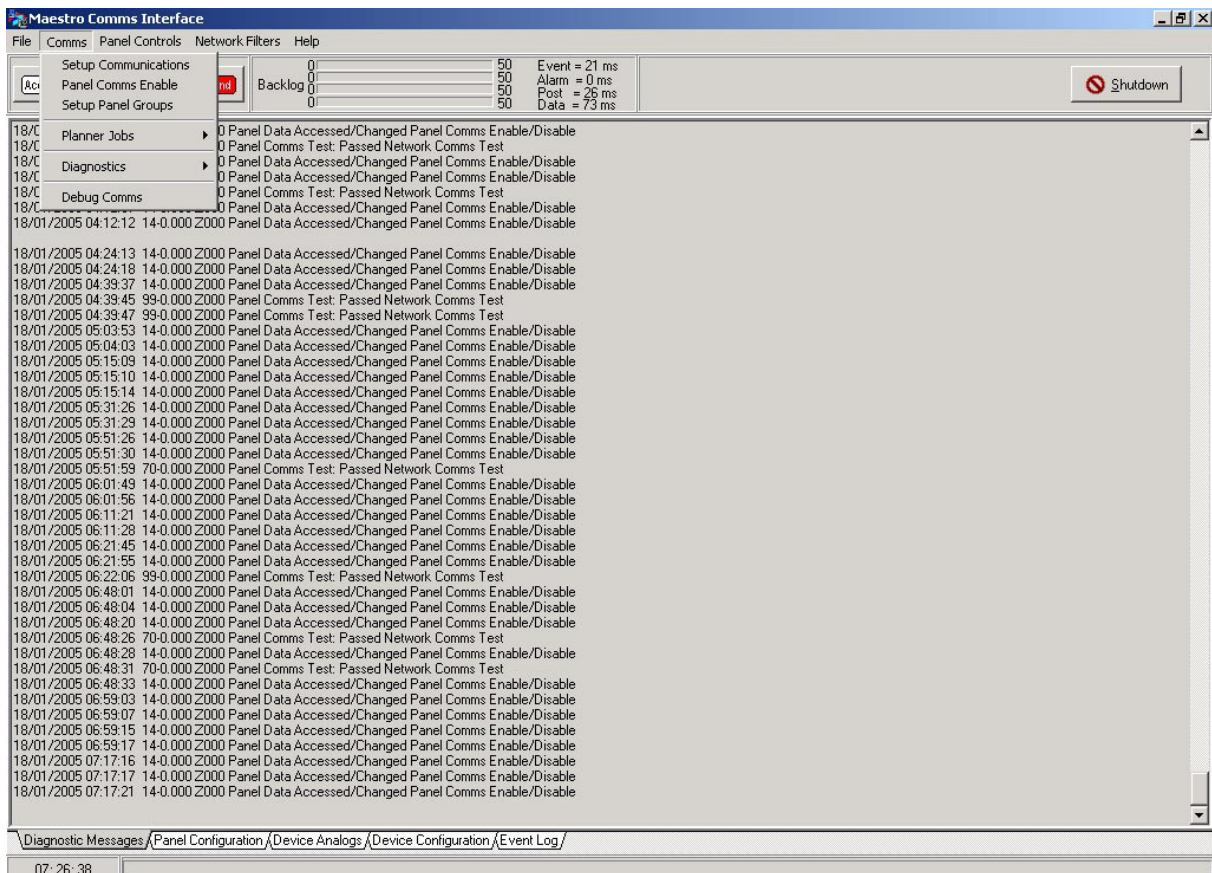

# Maestro Graphics System

## Installing the Maestro Package

4.1.5. Edit the relevant COM port settings.

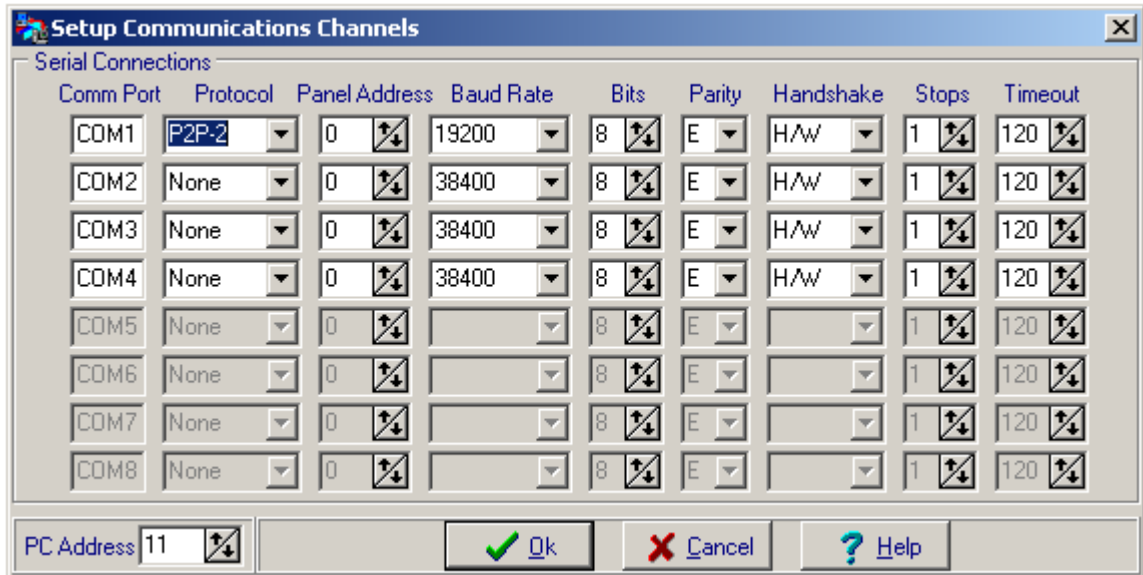

4.1.6. **Panel Comms Enable function.** This feature provides for temporarily disabling a node from the network, typically used during commissioning of the system or of a panel being added to the network. When disabled, a node no longer receives nor sends any messages into the network, and all other nodes in the network do not expect the disabled node to be present. Navigate to Maestro Comms\Comms\Panel comms enable. When selected, a dialog is displayed from which nodes may be selected to be present or otherwise. Controls to select all, none or reverse a selection are provided. When the Send button is clicked, a message is sent to all nodes in the network to affect the settings chosen. A panel disabled in this way will remain isolated from the network communications until it is reinstated. A warning light on the panel is illuminated, and Maestro will show the panel as Offline, with a disabled message in the Information category.

**Note:** *Panel comms must be selected and sent to established comms.*

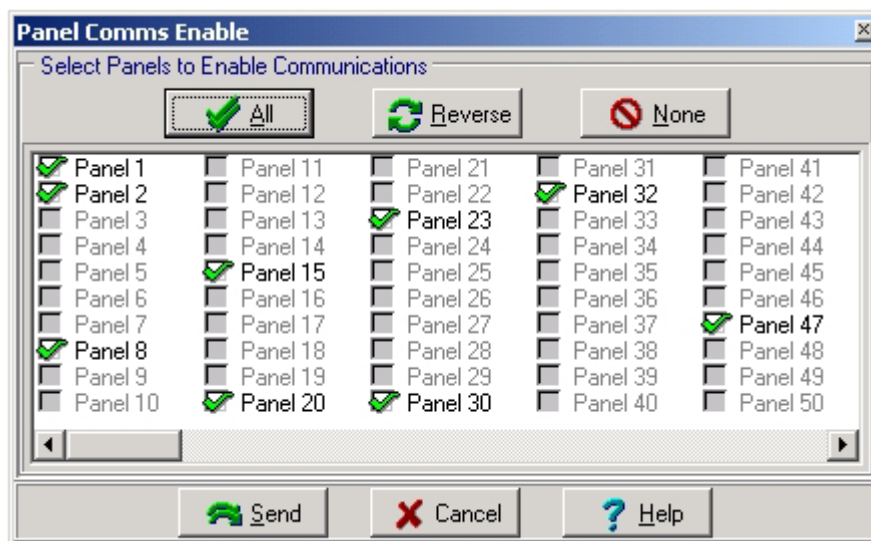

# Maestro Graphics System

## Installing the Maestro Package

### 4.2 Option 2 (advanced users) - Regedit option for restore comms settings

- 4.2.1. Ensure both Maestro and MaestroComms are shut down.
- 4.2.2. Ensure there are no other applications running on the PC, especially any that may be using the Borland Database Engine (BDE).
- 4.2.3. Make a Backup! Prior to commencing installation of this version of Maestro it is imperative to make a complete backup of the existing Maestro Database. This may be accomplished by making a copy of the Maestro Database folder using Windows Explorer. This directory and all it's contained files should be copied to a convenient folder located either on the same drive, or to a zip drive if one is available.
- 4.2.4. Un-install Maestro by selecting Add/Remove Programs from the Settings/Control Panel window. This step is required if installation of the new version is to proceed.
- 4.2.5. Insert the CD into the appropriate drive on the PC. The Maestro Setup application should start up automatically, alternatively, select Start/Run and enter D:\Setup and press enter.
- 4.2.6. Follow the screen prompts, installing Maestro into the same folder as it previously was.
- 4.2.7. If prompted to re-start the computer at the end of the installation process, this may indicate a problem installing the Borland Database Engine, or merging the required setup parameters into the BDE configuration file. If possible do not select the restart option now, it may be done later.
- 4.2.8. Start MaestroComms to verify that all the data tables have been installed correctly. Note that the installation will contain no site data. Shut down MaestroComms once startup has completed.
- 4.2.9. Start Maestro and login using the password 'install'. Open the Commissioning Tools window.
- 4.2.10. Select "File\Restore\Restore Tag Database" and navigate to the folder where the backup of the site data was made, and restore the tag database from that folder.
- 4.2.11. Repeat the above exercise for each of the Map, Panel, User and Icon Databases.
- 4.2.12. Select the Icon Database tab to open the Icon Editor screen.
- 4.2.13. Select Restore Defaults on the Icon Editor screen to set the default icons to the (new) default values.
- 4.2.14. Once the above restore operations have been completed, the Maestro installation will have the same site data as before commencing the installation. Shut down Maestro.
- 4.2.15. Confirm that the BDE configuration settings are correct by starting up the BDE Administrator utility from the Settings/Control Panel window. If in any doubt, the correct configuration file is available on the CD under D:\Common\Borland Shared\BDE\ldapi32.cfg. Shutdown BDE Administrator and copy the file from the CD to the folder C:\Program Files\Common Files\Borland Shared\BDE.
- 4.2.16. If it is required to preserve the original site Event log and Event Archive log, the files Event.\* and EventArchive.\* should be copied using Windows Explorer from the backup folder to the Maestro database folder.
- 4.2.17. If the registry was not previously saved, the settings for the communications protocol(s) for each channel will have been lost and need to be re-entered before MaestroComms will function normally. To do this, start MaestroComms, bring the application to the desktop (double-click the MaestroComms Tray Icon and enter the password 'install'), select 'Comms Settings' and enter the appropriate settings for protocol, baud rate, timeout and PC number'.

# Maestro Graphics System

## Installing the Maestro Package

Close the dialog and confirm that all the selected channels have startup up and that normal communications between Maestro and the Panel network(s) has been initiated.

- 4.2.18. Shutdown and reboot the PC. On startup, MaestroComms and Maestro should automatically start up and run normally with the original configuration data.

### 5. Restore Maestro database

This procedure should be followed after setting up Maestro Comms. Once the restore procedure has been completed Maestro Comms will update the installation to the latest format.

#### Procedure

- 5.1. Close Maestro Comms. Choose Yes when prompted for confirmation.

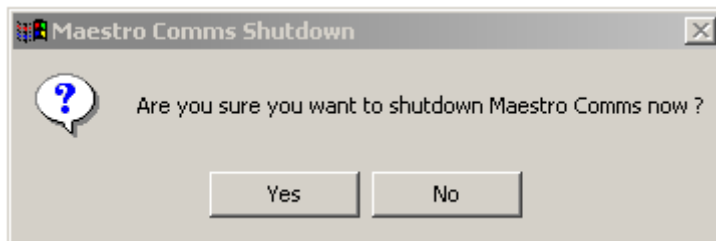

- 5.2. Open the Maestro GUI. At this stage the form will not contain any icon information.
- 5.3. Click the Commission Tools Icon. Enter the password "install" when prompted.
- 5.4. Navigate to File\Restore (Commissioning details) and select a database to be restored. Repeat steps 5.4 to 5.6 for each database to be restored.

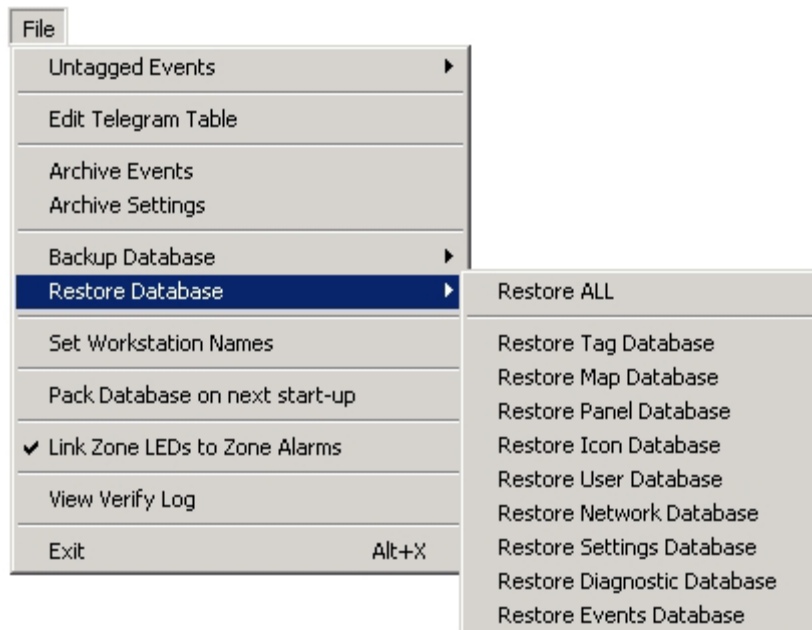

# Maestro Graphics System

## Installing the Maestro Package

- 5.5. The following warning message will be displayed when a restore option is selected. Click on the OK button to proceed.

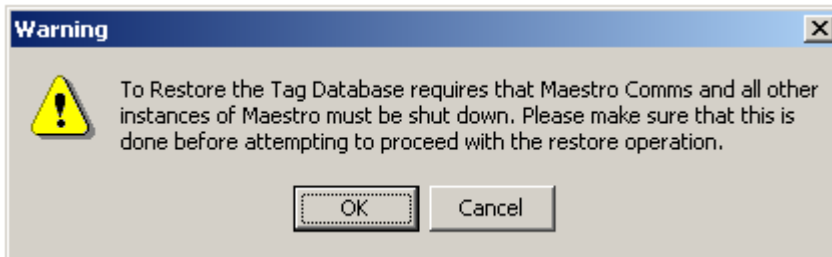

- 5.6. Select the database to restore using the file open dialog box.

The following files should be restored:

- database (tag.db)
- map (page.db)
- panel (panel.db)
- icon (icon.db)
- user (password.db)

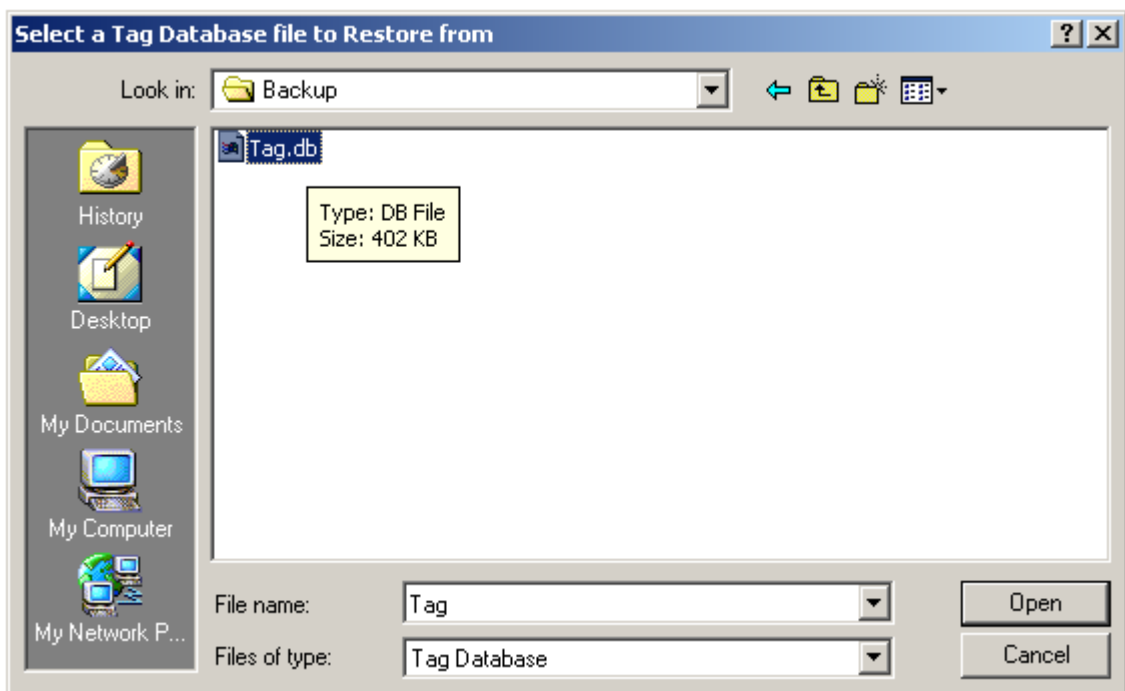

- 5.7. Close the commissioning module after all the backup databases have been restored.

# Maestro Graphics System

## Installing the Maestro Package

### 6. Verifying the panel configuration

Once the panel configuration has been completed, the settings must be verified using the following procedure. Note: the Configure Panels form may also be used to edit the configuration of single panels.

- 6.1 Click on "Network Filters" (Maestro Comms Interface, main toolbar) to launch Configure Panels form.

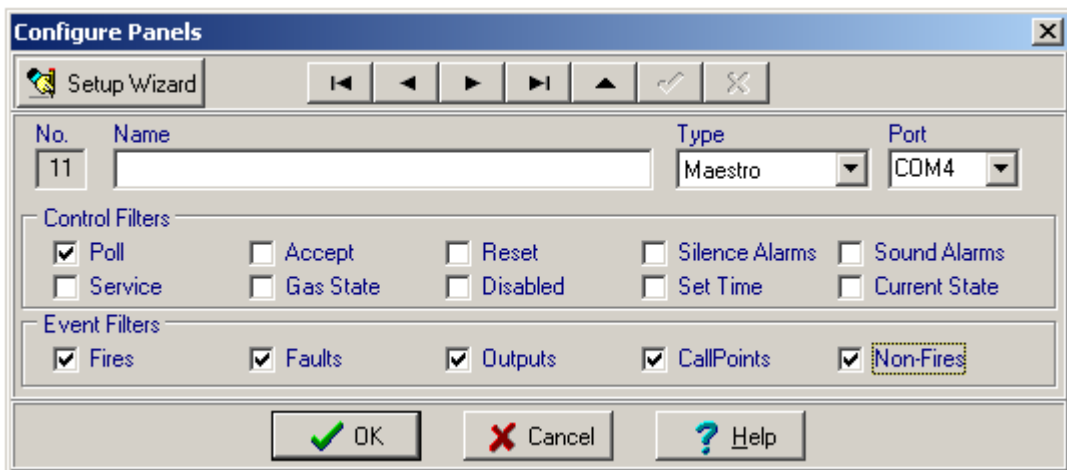

- 6.2 Set Type to ZP3 and scroll through the panel settings using the play button to check that the filter settings for each panel are correct.
- 6.3 Set Type to Maestro and scroll through the panel settings using the play button to check that the Maestro settings for the relevant Maestro workstations are correct.
7. Open comms\setup communication filters. Ensure that the COM port setting is correct as the hardware on the database backup may have been set differently.
8. Open Maestro Comms.
9. Open the Maestro GUI.
10. Maestro site commissioning may now be done.

# Maestro Graphics System

## Installing the Maestro Package

### 2.3.2. New installation

The user will have to configure how many panels are on the network. Following this procedure if Maestro has not previously been installed.

1. Installation wizard
  - 1.1. Run setup.exe (Maestro installation CD) to launch the installation wizard.

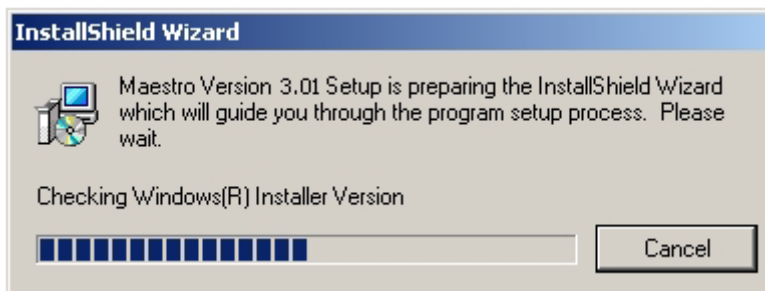

- 1.2. Select Install new Version and follow the prompts.

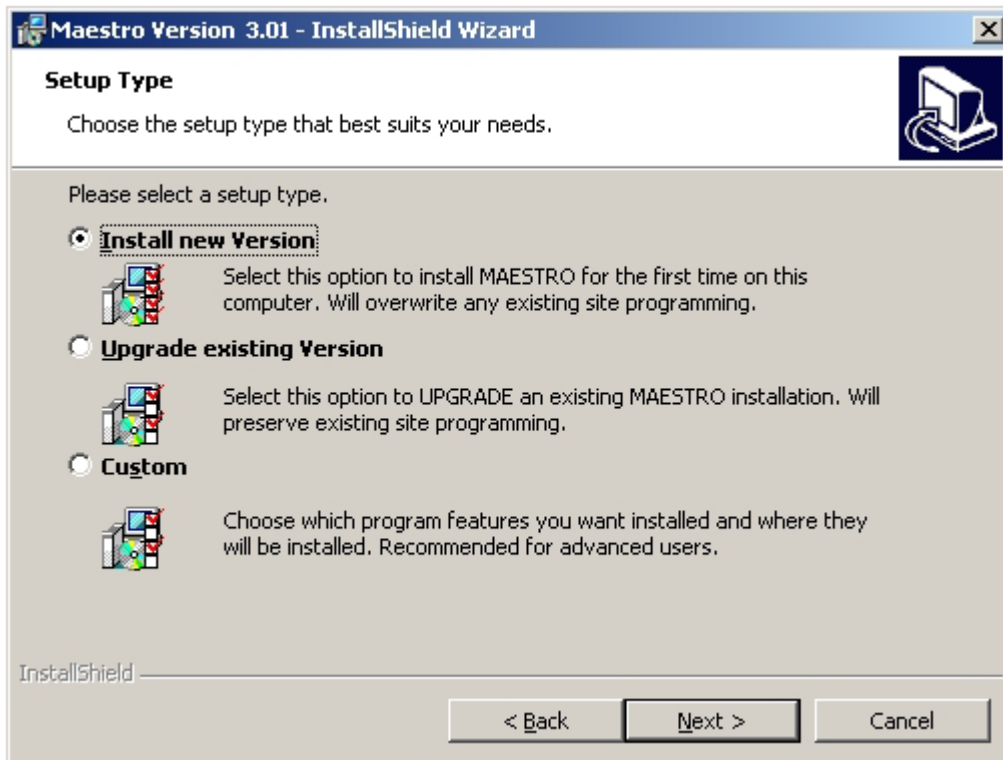



# Maestro Graphics System

## Installing the Maestro Package

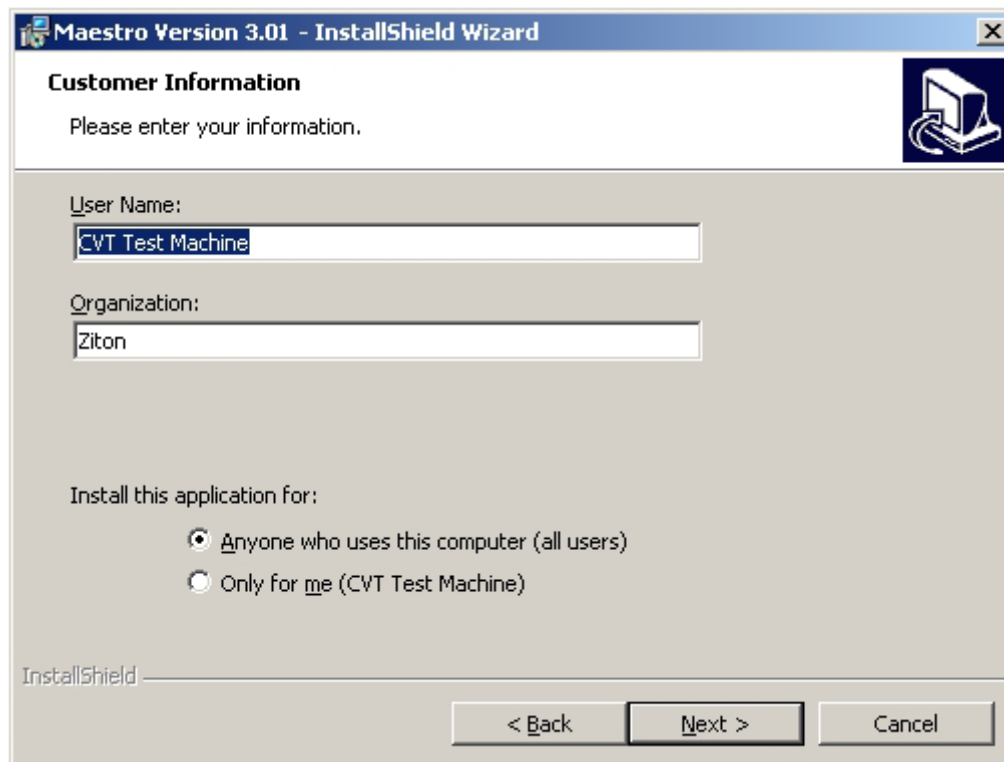
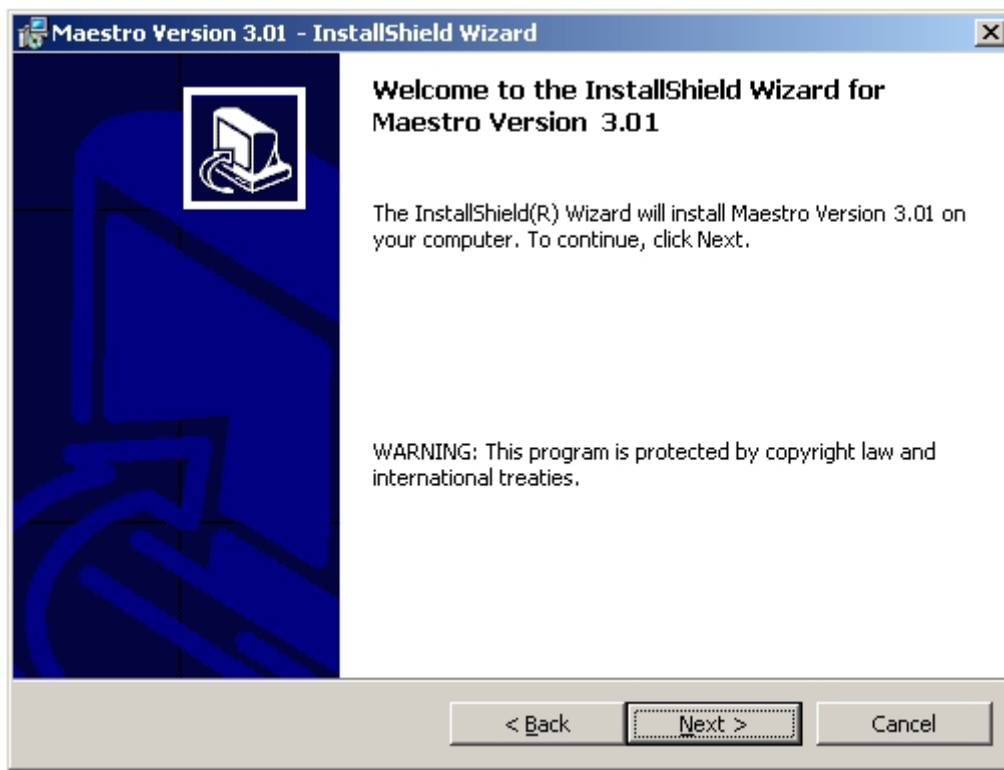

Note: The option for 'all users' is recommended.

# Maestro Graphics System

## Installing the Maestro Package

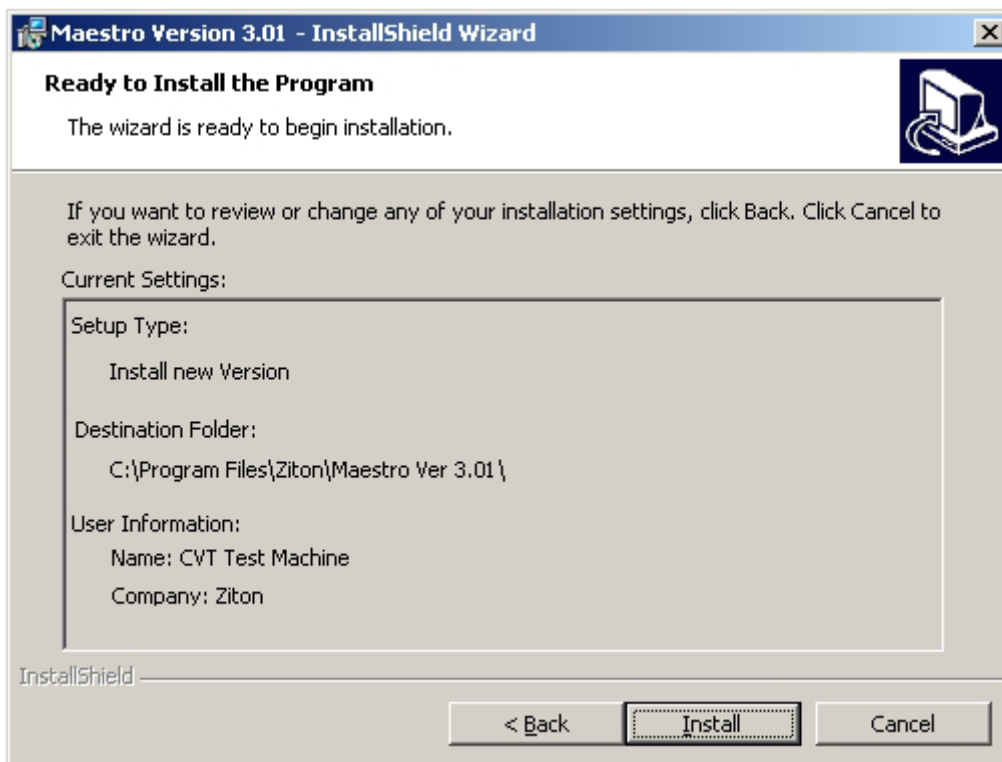
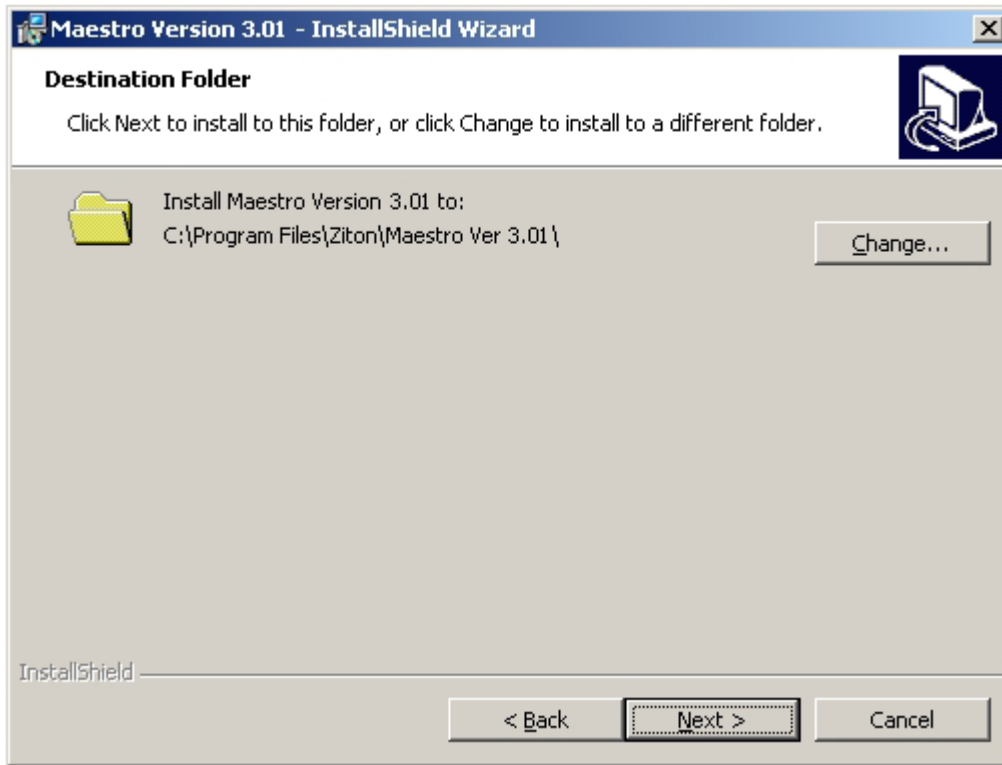

# Maestro Graphics System

## Installing the Maestro Package

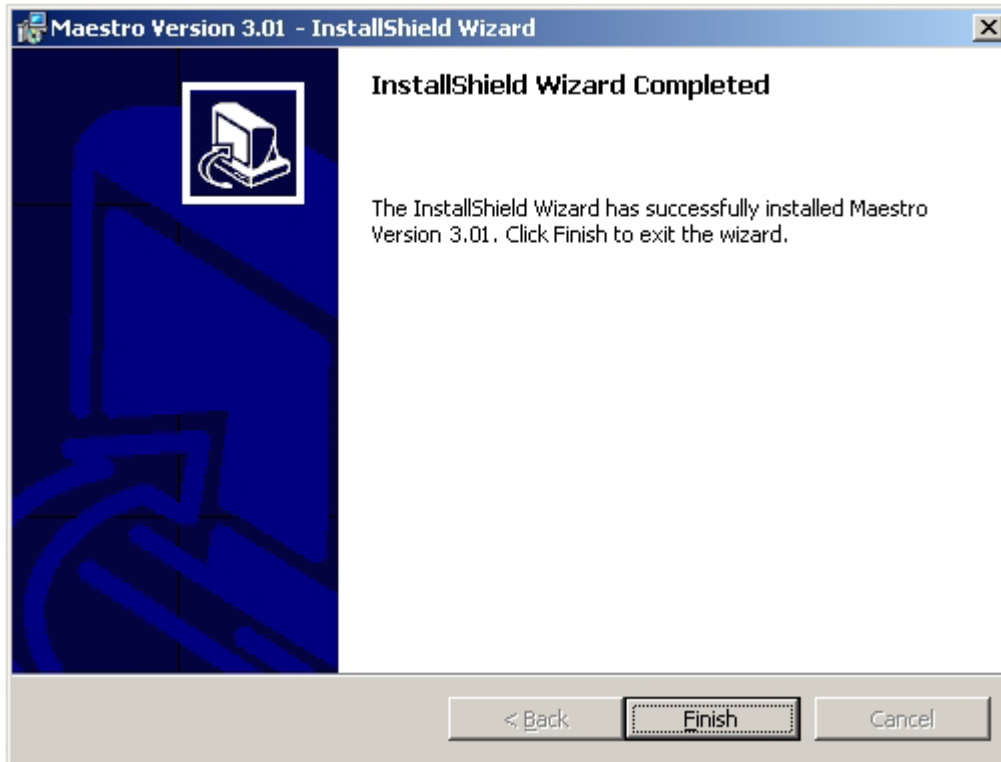

2. Maestro Comms Setup. After the Install wizard setup is completed the Comms settings must be configured.  
Two setup options are available.

**2.1 Option 1 (recommended)**

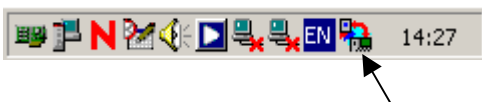

- 2.1.1 Open Maestro Comms by right clicking on the Maestro icon (bottom, right taskbar).

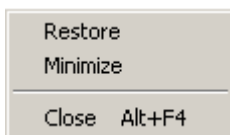

- 2.1.2 Select the restore option.

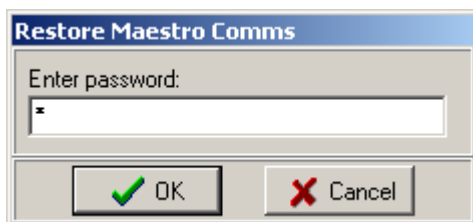

- 2.1.3 Enter the user password at the prompt. The initial password after installing Maestro is "install"

# Maestro Graphics System

## Installing the Maestro Package

2.1.4 Click on Comms\Setup Communications to display the communication channels setup form.

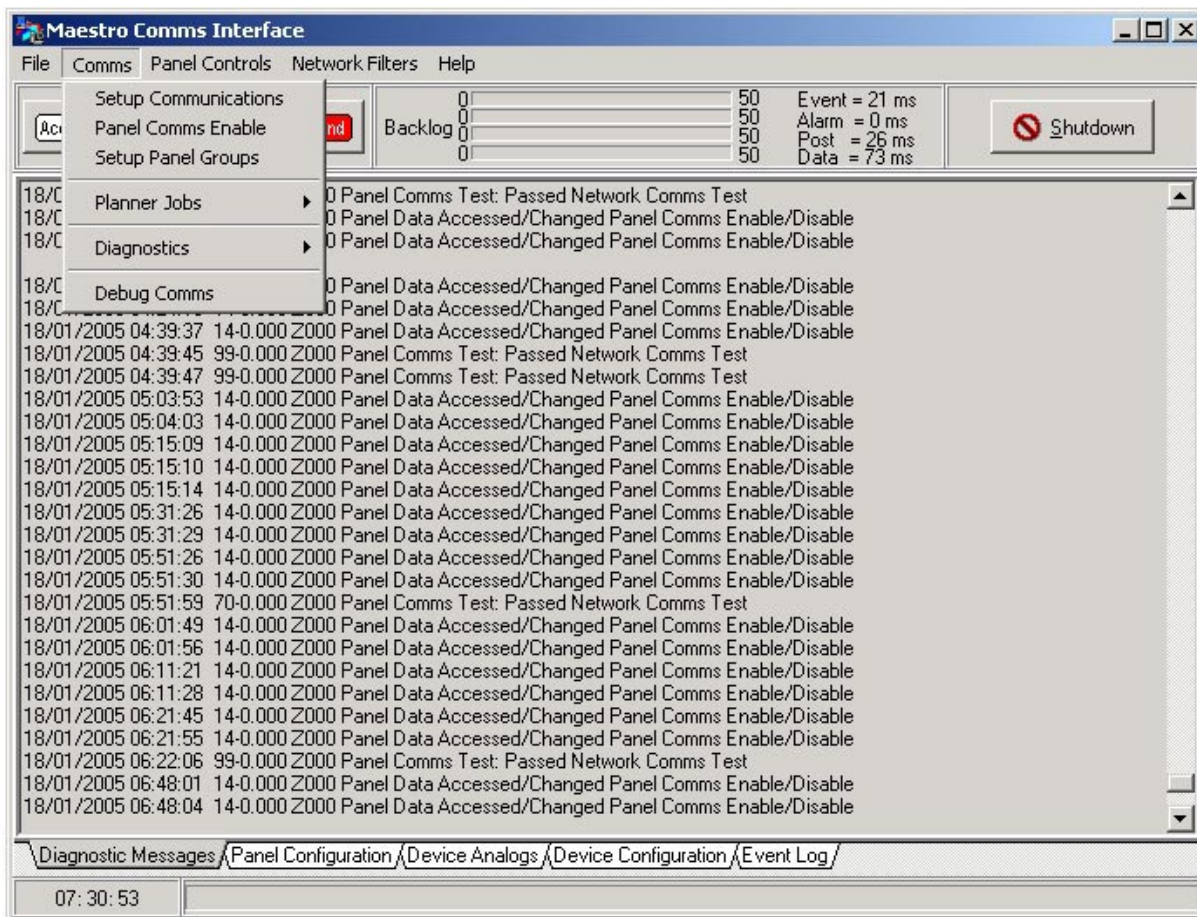

2.1.5 Edit the relevant COM port settings.

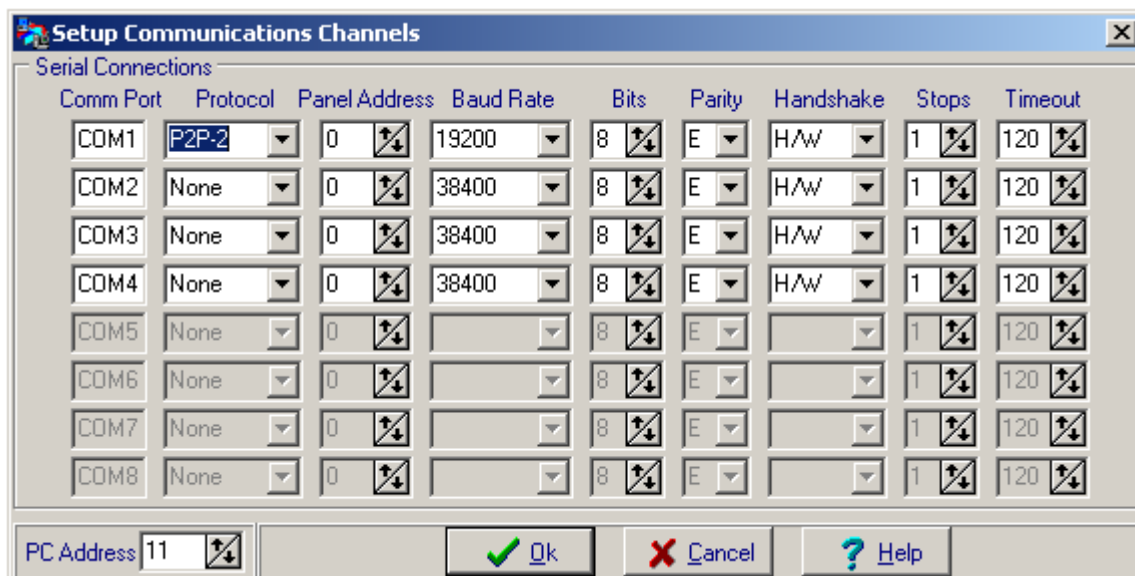

# Maestro Graphics System

## Installing the Maestro Package

- 2.1.6. **Panel Comms Enable function.** This feature provides for temporarily disabling a node from the network, typically used during commissioning of the system or of a panel being added to the network. When disabled, a node no longer receives nor sends any messages into the network, and all other nodes in the network do not expect the disabled node to be present. Navigate to Maestro Comms\Comms\Panel comms enable. When selected, a dialog is displayed from which nodes may be selected to be present or otherwise. Controls to select all, none or reverse a selection are provided. When the Send button is clicked, a message is sent to all nodes in the network to affect the settings chosen. A panel disabled in this way will remain isolated from the network communications until it is reinstated. A warning light on the panel is illuminated, and Maestro will show the panel as Offline, with a disabled message in the Information category.

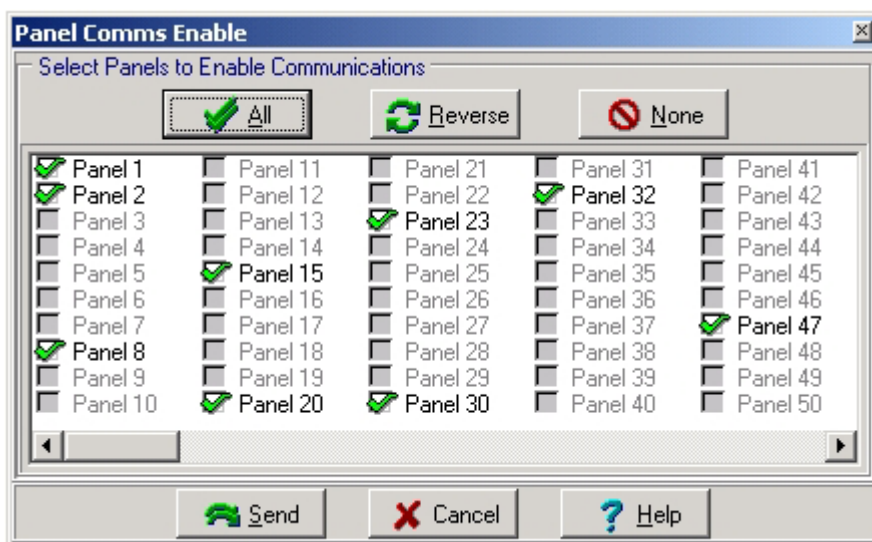

- 2.2 Option 2 (advanced users) - Regedit option for restore Comms settings
- 2.2.1. Ensure both Maestro and MaestroComms are shut down.
- 2.2.2. Ensure there are no other applications running on the PC, especially any that may be using the Borland Database Engine (BDE).
- 2.2.3. Make a backup of the relevant entries in the Windows System Registry for the key HKEY\_LOCAL\_MACHINE\SOFTWARE\Ziton\Maestro. To do this, select Start/Run... and enter REGEDIT in the dialog and press enter. Locate the key HKEY\_LOCAL\_MACHINE\SOFTWARE\Ziton\Maestro, then select Export Registry File. Enter a suitable folder name and file name where the registry branch should be saved. (this step is optional)
- 2.2.4. If installation of the new version is to proceed then un-install Maestro by selecting Add/Remove Programs from the Settings/Control Panel window.
- 2.2.5. Insert the CD into the appropriate drive on the PC. The Maestro Setup application should start up automatically, alternatively, select Start/Run and enter D:\Setup and press enter.
- 2.2.6. Follow the screen prompts, installing Maestro into the same folder as it previously was.

# Maestro Graphics System

## Installing the Maestro Package

- 2.2.7. If prompted to re-start the computer at the end of the installation process, this may indicate a problem installing the Borland Database Engine, or merging the required setup parameters into the BDE configuration file. If possible do not select the restart option now, it may be done later.
- 2.2.8. Start MaestroComms to verify that all the data tables have been installed correctly. Note that the installation will contain no site data. Shut down MaestroComms once startup has completed.
- 2.2.9. Start Maestro and login using the password 'install'. Open the Commissioning Tools window.
- 2.2.10. Select "File\Restore\Restore Tag Database" and navigate to the folder where the backup of the site data was made, and restore the tag database from that folder.
- 2.2.11. Repeat the above exercise for each of the Map, Panel, User and Icon Databases.
- 2.2.12. Select the Icon Database tab to open the Icon Editor screen.
- 2.2.13. Select Restore Defaults on the Icon Editor screen to set the default icons to the (new) default values.
- 2.2.14. Once the above restore operations have been completed, the Maestro installation will have the same site data as before commencing the installation. Shut down Maestro.
- 2.2.15. Confirm that the BDE configuration settings are correct by starting up the BDE Administrator utility from the Settings/Control Panel window. If in any doubt, the correct configuration file is available on the CD under D:\Common\Borland Shared\BDE\ldapi32.cfg. Shutdown BDE Administrator and copy the file from the CD to the folder C:\Program Files\Common Files\Borland Shared\BDE.
- 2.2.16. If it is required to preserve the original site Event log and Event Archive log, the files Event.\* and EventArchive.\* should be copied using Windows Explorer from the backup folder to the Maestro database folder.
- 2.2.17. If the registry was not previously saved, the settings for the communications protocol(s) for each channel will have been lost and need to be re-entered before MaestroComms will function normally. To do this, start MaestroComms, bring the application to the desktop (double-click the MaestroComms Tray Icon and enter the password 'install'), select 'Comms Settings' and enter the appropriate settings for protocol, baud rate, timeout and PC number'. Close the dialog and confirm that all the selected channels have startup up and that normal communications between Maestro and the Panel network(s) has been initiated.
- 2.2.18. Shutdown and reboot the PC. On startup, MaestroComms and Maestro should automatically start up and run normally with the original configuration data.

# Maestro Graphics System

## Installing the Maestro Package

### 3. Configuring the panel network filters using the Panel Setup Wizard.

The Panel Setup Wizard will be used to configure the panel network filters.

- 3.1. Launch the Panel Setup Wizard by clicking on the Setup Wizard button on the Configure Panels form.

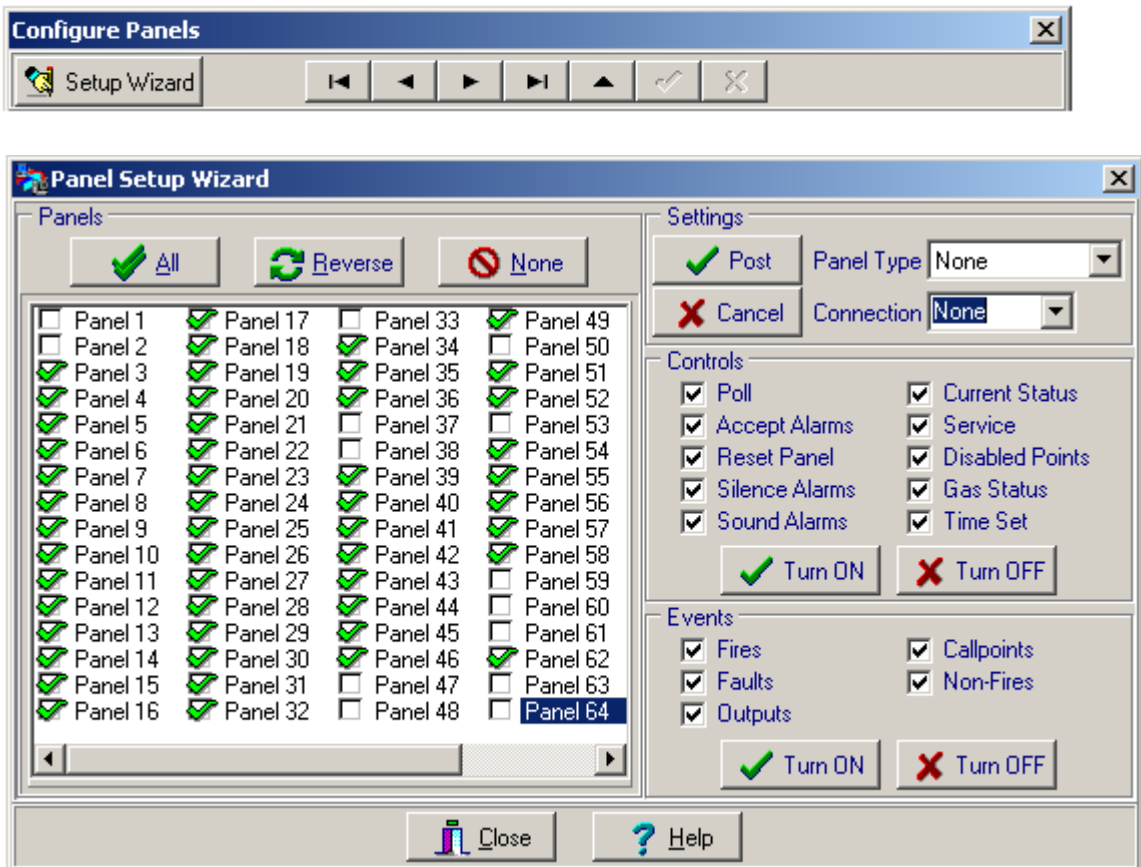

- 3.2. Select the COM port from the Connection dropdown menu.

- 3.3. Select the panels in the network to be configured.

- i. Select the desired options for Controls and Events.
  - Point status (service) will be reported if current status is selected.
  - If the service tick box is selected then zone service conditions will be reported.
- ii. Click on the Turn ON button (Controls).
- iii. Click on the Turn ON button (Events).
- iv. Click on the Post button to apply the configuration to the panels selected in 3.3.

# Maestro Graphics System

## Installing the Maestro Package

- 3.4. Click on the Reverse button to invert the panel selection. This will select panels that are not part of the network.
  - i. Select all options for Control and Events respectively.
  - ii. Click on the Turn OFF button (Controls).
  - iii. Click on the Turn OFF button (Events).
  - iv. Set Panel Type to None.
  - v. Set Connection to None.
  - vi. Click on the Post button to apply the configuration (i to v) to the panels selected in 3.4. This will complete the panel configuration.
- 3.5. Click on the Close button to close the form.

### 4. Verifying the panel configuration

Once the panel configuration has been completed, the settings must be verified using the following procedure. Note: the Configure Panels form may also be used to edit the configuration of single panels.

- 4.1 Click on "Network Filters" (Maestro Comms Interface, main toolbar) to launch Configure Panels form.

No.	Name	Type	Port
11		Maestro	COM4

**Control Filters**

<input checked="" type="checkbox"/> Poll	<input type="checkbox"/> Accept	<input type="checkbox"/> Reset	<input type="checkbox"/> Silence Alarms	<input type="checkbox"/> Sound Alarms
<input type="checkbox"/> Service	<input type="checkbox"/> Gas State	<input type="checkbox"/> Disabled	<input type="checkbox"/> Set Time	<input type="checkbox"/> Current State

**Event Filters**

<input checked="" type="checkbox"/> Fires	<input checked="" type="checkbox"/> Faults	<input checked="" type="checkbox"/> Outputs	<input checked="" type="checkbox"/> CallPoints	<input checked="" type="checkbox"/> Non-Fires
---	--	---	--	---

- 4.2 Set Type to ZP3 and scroll through the panel settings using the play button to check that the filter settings for each panel are correct.
- 4.3 Set Type to Maestro and scroll through the panel settings using the play button to check that the Maestro settings for the relevant Maestro workstations are correct.
- 5 Run Maestro Comms.
- 6 Run the Maestro GUI.
7. Maestro site commissioning may now be done.



# Maestro Graphics System

## Installing the Maestro Package

### 2.3.3. Upgrade – using the install shield

The user will have to configure how many panels are on the network.

Follow this procedure if you are upgrading from a previous version of Maestro.

#### 1. Backup the current installation of Maestro

- 1.1. Backup the current Maestro databases using the Maestro backup facility. Proceed as follows.
- 1.2. Select File\Backup Database (MaestroComms interface).
- 1.3. Backup the following Maestro databases:

- Tag Database
- Map Database
- Panel Database
- Icon Database
- User Database
- Network Database
- Settings Database
- Diagnostic Database
- Events Database

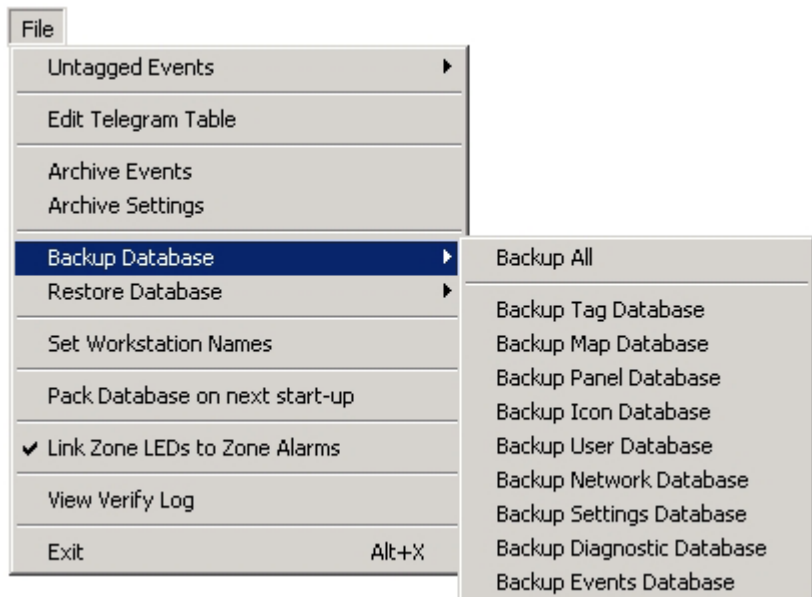

This procedure should be repeated for each database backup.

- 1.4. Click on the OK button to confirm the backup path.

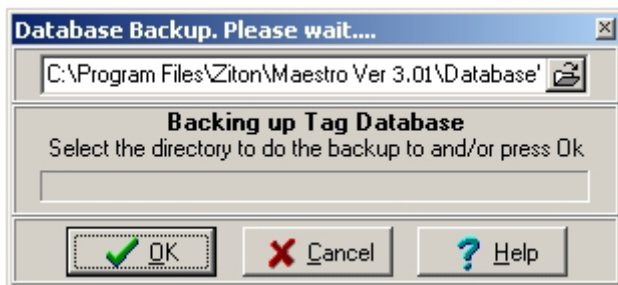

# Maestro Graphics System

## Installing the Maestro Package

- 1.5. Click on the Yes button when prompted for confirmation. If the user wants to backup individual databases they can be selected from the dropdown menu. If all the databases are to be backed up use the 'Backup All' option.

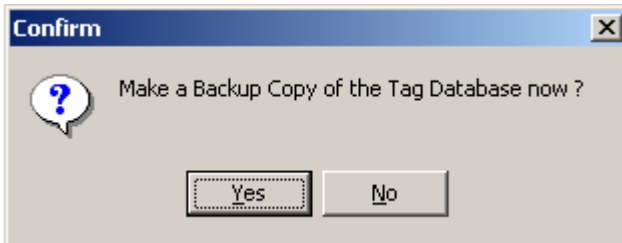

- 1.6. Using windows explorer, copy the maps to the map folder in the new installation directory structure.

### 2. Installation wizard

- 2.1. Run setup.exe (Maestro installation CD) to launch the installation wizard.

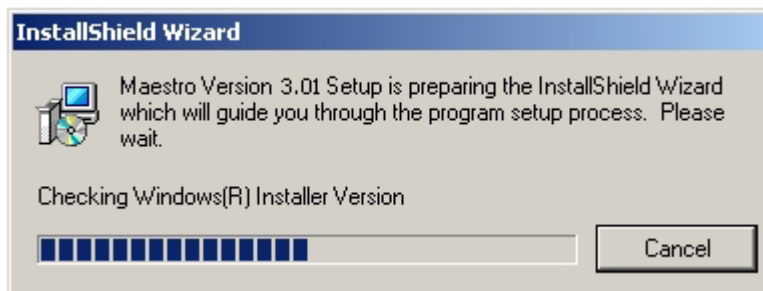

- 2.2. Select Upgrade existing Version and follow the prompts.

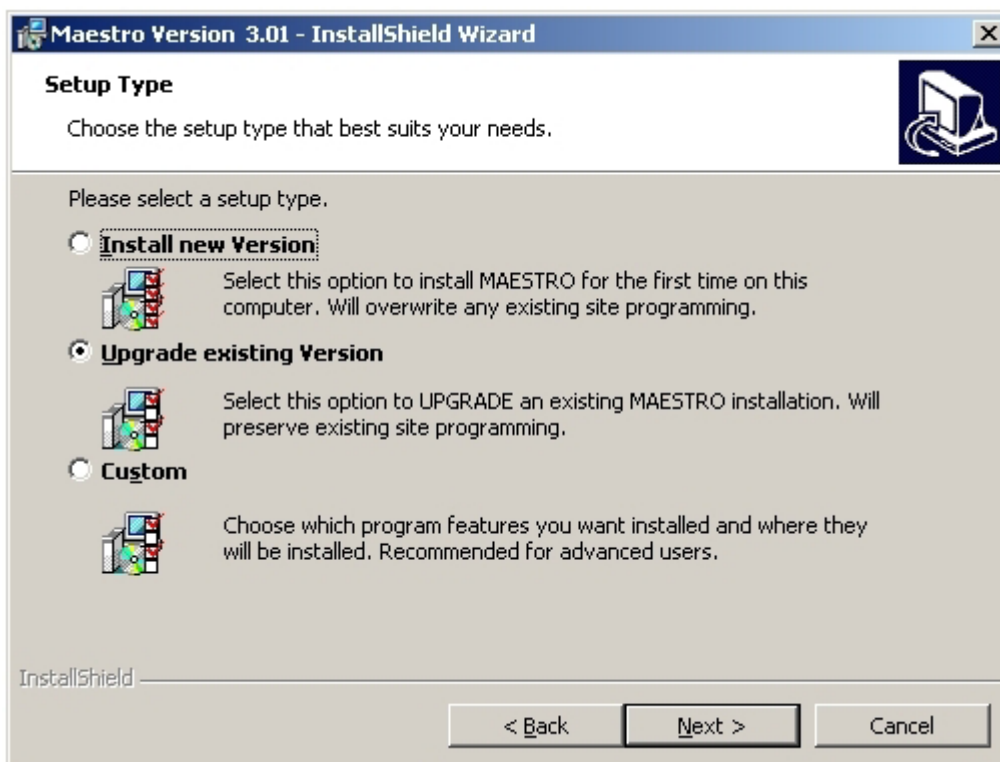

# Maestro Graphics System

## Installing the Maestro Package

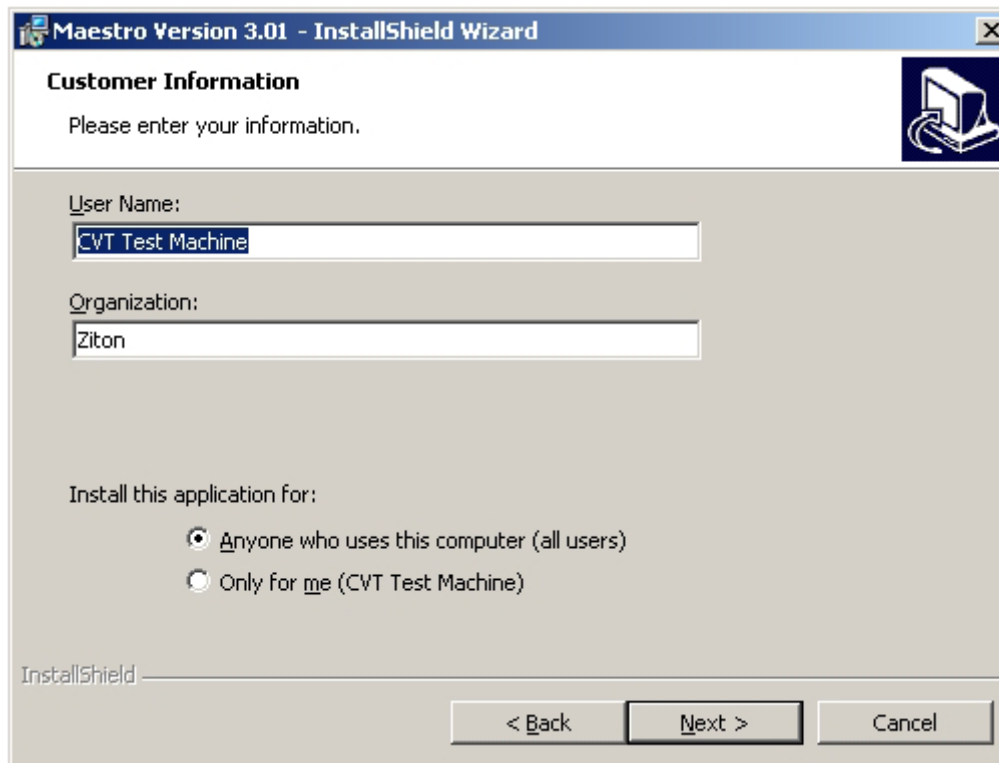
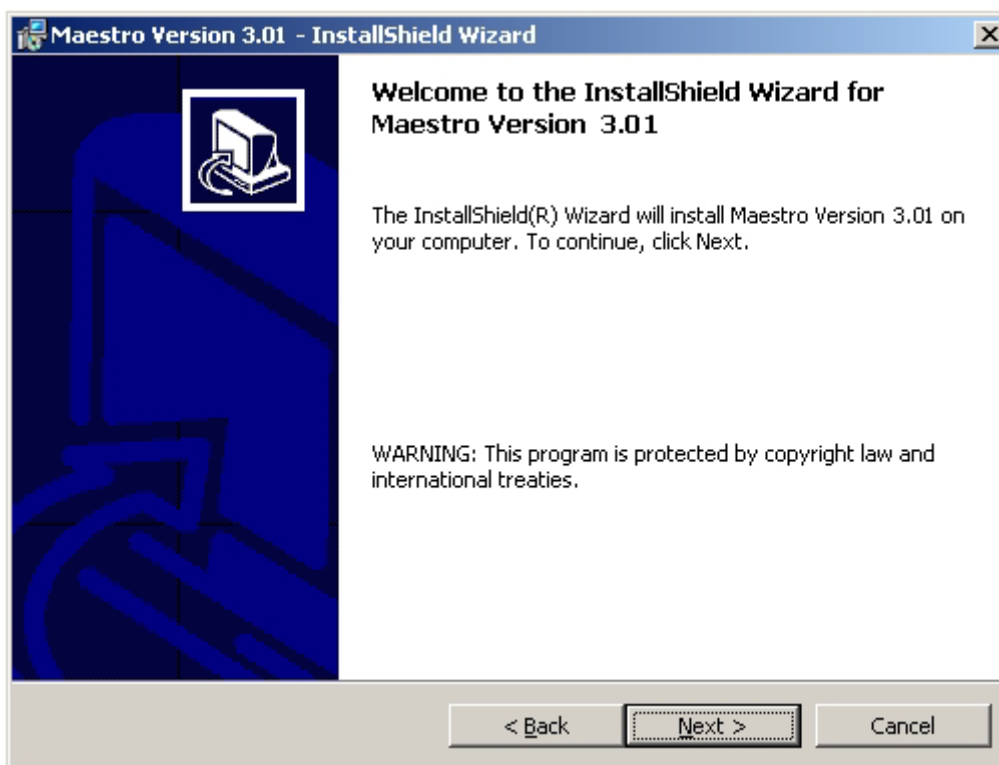

Note: The option for 'all users' is recommended.

# Maestro Graphics System

## Installing the Maestro Package

2.3 Click on the Change button and set the installation path to the current Maestro installation.

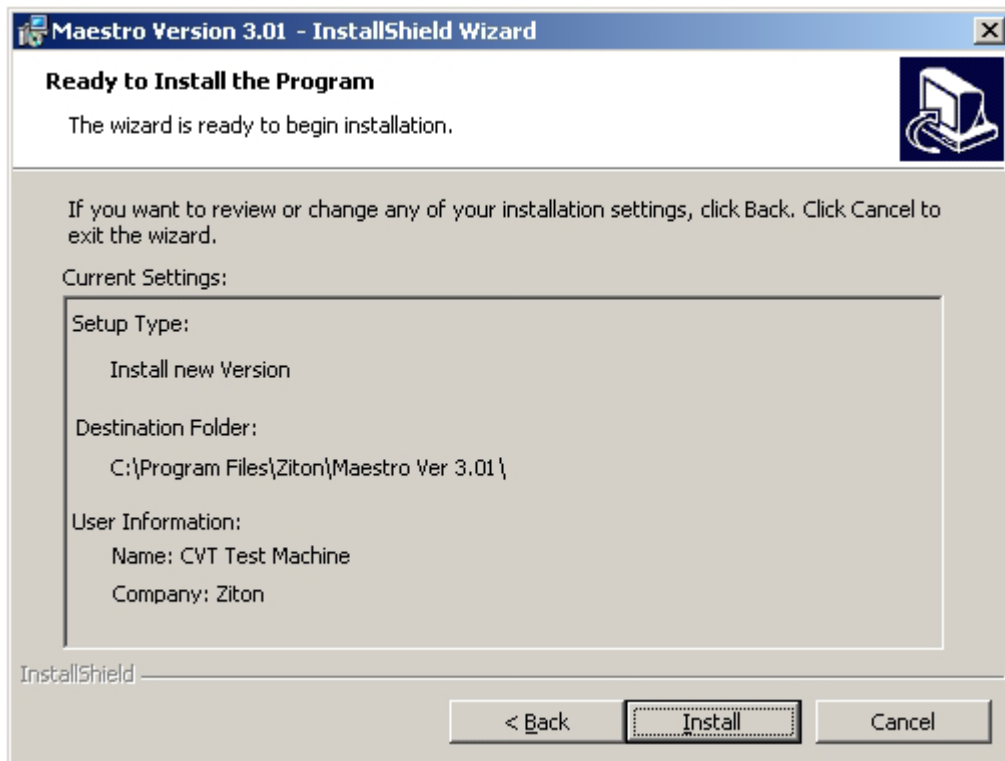
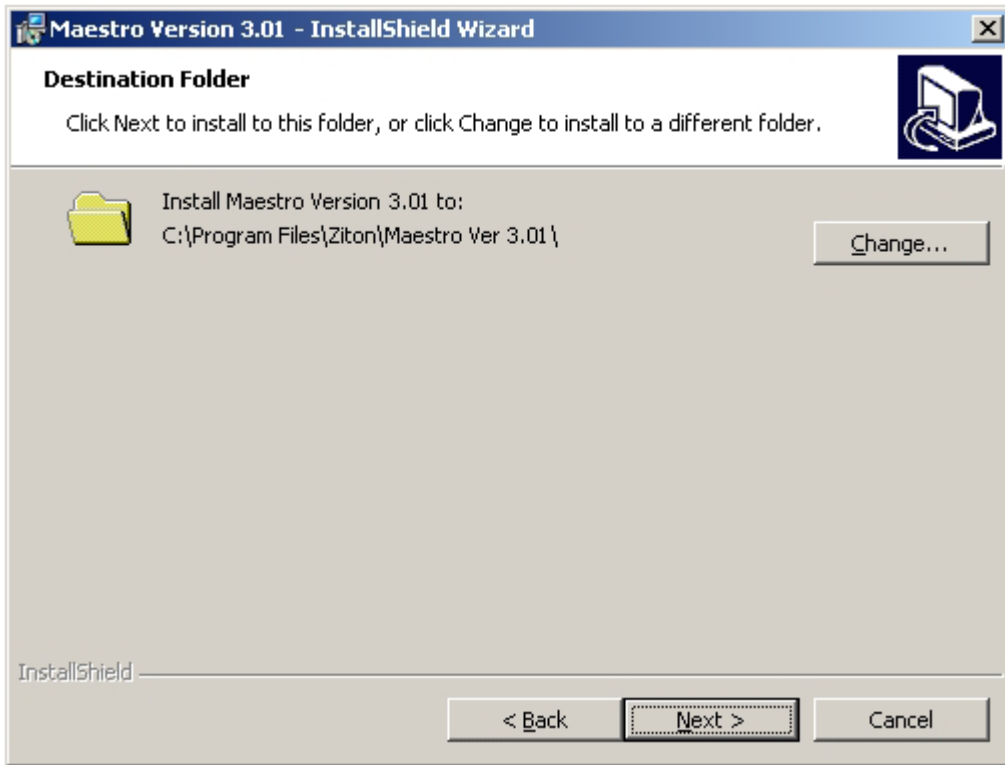

# Maestro Graphics System

## Installing the Maestro Package

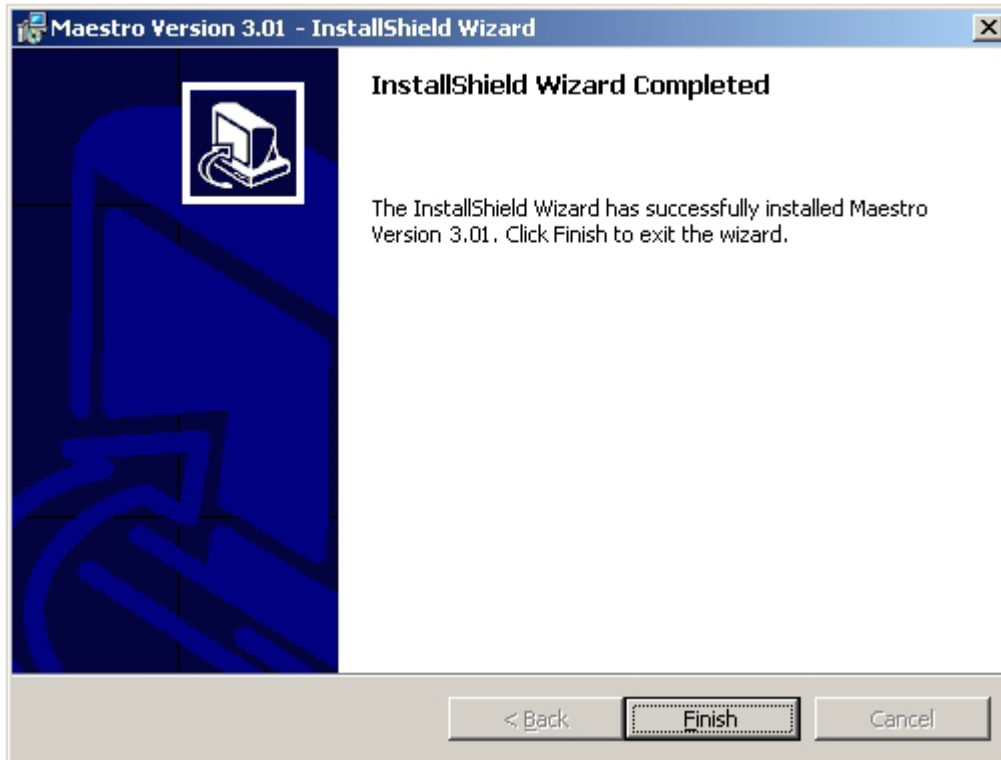

### 3. Verifying the panel configuration

Once the panel configuration has been completed, the settings must be verified using the following procedure. Note: the Configure Panels form may also be used to edit the configuration of single panels.

- 3.1 Click on "Network Filters" (Maestro Comms Interface, main toolbar) to launch Configure Panels form.

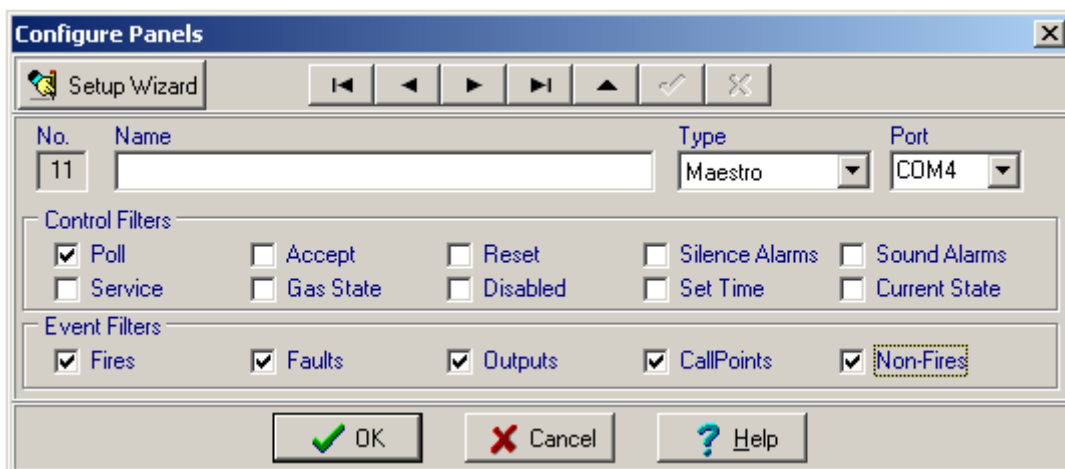

- 3.2 Set Type to ZP3 and scroll through the panel settings using the play button to check that the filter settings for each panel are correct.

# Maestro Graphics System

## Installing the Maestro Package

- 3.3 Set Type to Maestro and scroll through the panel settings using the play button to check that the Maestro settings for the relevant Maestro workstations are correct.
4. Open Comms\Setup Communication Filters. Ensure that the COM port setting is correct as the hardware on the database backup may have been set differently.
5. Run Maestro comms.
6. Run the Maestro GUI.
7. Maestro site commissioning may now be done.

## 2.4. Changing default configurations and regional settings

After the completion of the initial installation of the MAESTRO programme, the software should run trouble free, provided all the default settings have been correctly applied.

Information on changing default settings and regional options is detailed in Appendix B.

## 2.5. Dongle installation

To install the dongle, the following steps should be taken.

1. Remove the CD from the CD ROM Drive and shut down the system. Insert the dongle into the workstation parallel port and restart the workstation to reboot the system.
2. If MAESTRO and/or MAESTRO COMMS are running, they both must be shut down.
3. Open the Start Menu by clicking on the Start button and select "Run".  
Type "C:\Program files\Ziton\Maestro\HDD32.exe" and press Enter or click onto "OK".  
When prompted by the installation dialogue box, select the Typical installation to install the dongle driver.
4. Shut down the workstation again and restart it. MAESTRO COMMS and MAESTRO will restart without the "Demonstration Mode" dialogue being displayed.

# Maestro Graphics System Commissioning Manual

## Section 3 Maestro Communications Interface

UD1277.3  
Issue 3  
10/01/2005





# Maestro Graphics System

## Maestro Communications Interface

### 3.1. Communications introduction and overview

MAESTRO communicates with the fire detection and alarm system by means of the MAESTRO COMMS application. The programme file is included on the MAESTRO CD-Rom and is automatically installed with the other programme files.

The comms system simplifies the configuration and commissioning of MAESTRO systems, of any size, from a single fire alarm control panel to large multi panel networks.

Input display screens are provided, with default values, covering the standard information requirements and settings to complete successful communications between the MAESTRO workstation and the fire alarm system.

Full diagnostic facilities display continuously updated information, enabling the commissioning engineer to quickly check a wide range of values and complete fault finding.

The MAESTRO COMMS programme provides facilities to enable the system manager to monitor two way data transmission and detect and quickly rectify problems should they arise.

#### 3.1.1. Accessing the communications interface

The Installation User default password is "install". This provides initial access to all programmes, including the User Database (Section 5.6.) where passwords can be assigned to users and the default cancelled.

The Comms Interface is accessed by right hand clicking onto the Comms Icon, displayed at the bottom right of the task bar (next to the current time).

Note, access to the Comms Interface depends upon the user access, assigned to the password holder in the User Database.

### 3.2. Communication interface screens

The communications between the MAESTRO workstation and the fire alarm system is monitored by five main workstation display screens.

The screens provide information diagnosis, both during initial communications set up at the system commissioning stage and subsequently as an aid to maintenance, fault finding and future system extension and modification.

1. **Diagnostic messages screen.** This display summarises all communication messages between the MAESTRO workstation and the fire detection and alarm system. The display and its functions are fully explained in Section 3.5.
2. **Panel configuration screen.** Detailed parameters are shown for each panel connected to the MAESTRO workstation. The display and its functions are fully explained in Section 3.6.

# Maestro Graphics System

## Maestro Communications Interface

3. **Device analogues screen.** Full details of every device's analogue values are listed, providing a complete profile of every point connected to the fire alarm system. The display and its functions are fully explained in Section 3.7.
4. **Device configuration screen.** Settings for each device throughout the fire alarm system are listed, enabling the commissioning engineer to check details of each point, for example zone designation, sensitivity levels and alarm verification. The display and its functions are fully explained in Section 3.8.
5. **Event Log Screen.** This screen provides a view of recent events in the system, used as a diagnostic tool to assist tracking down problems that may have occurred.

### 3.3. Communications screens toolbar functions

The Comms screen tool bar runs along the top of the main screen display and remains in view regardless of which main screen is currently displayed.

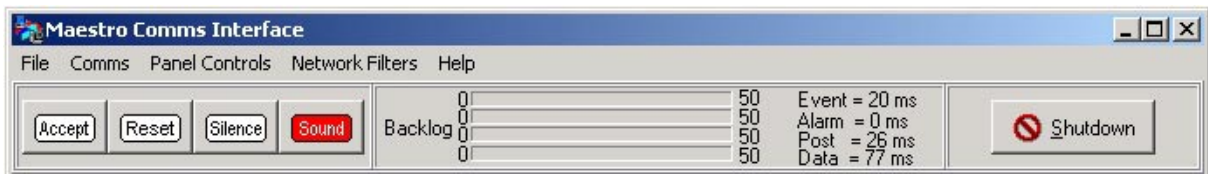

The toolbar provides the following functions.

1. **Accept, Reset, Silence Alarms and Sound Alarms buttons.** These controls can be used to test communications between the workstation and any panel. (Panels can be selected for test via the Select panels to control screen, see Section 5.4.3.)
2. **Backlog bar charts.** This shows the backlog of events already received by MAESTRO, but not yet written to the database.
3. **Events and alarms timing.** This shows the average delay time between an event arriving at MAESTRO and being written to the database.
4. **Shutdown button.** This shuts down the MAESTRO COMMS interface programme.

# Maestro Graphics System

## Maestro Communications Interface

### 3.4. Drop down menus

In conjunction with the toolbar and main screen functions, the communication interface is configured by facilities accessed via drop down menus. Menu headings are always shown along the top of the display, above the toolbar function, regardless of the screen in view.

#### 3.4.1. File

By clicking onto the File menu the following functions are accessed.

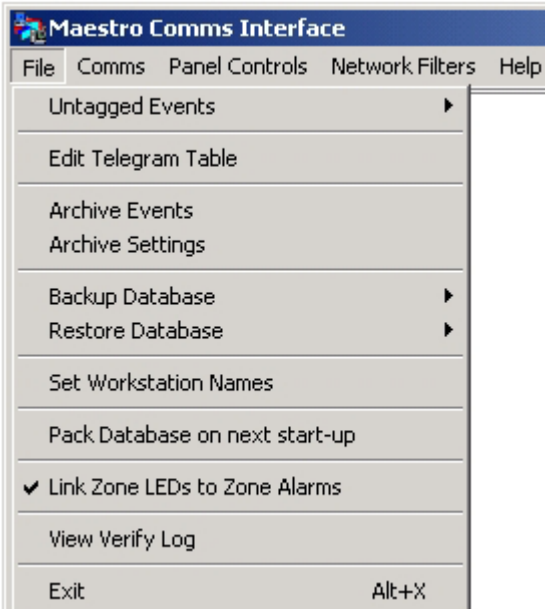

##### 3.4.1.1. Untagged events

Clicking onto the Untagged heading accesses the following sub menu.

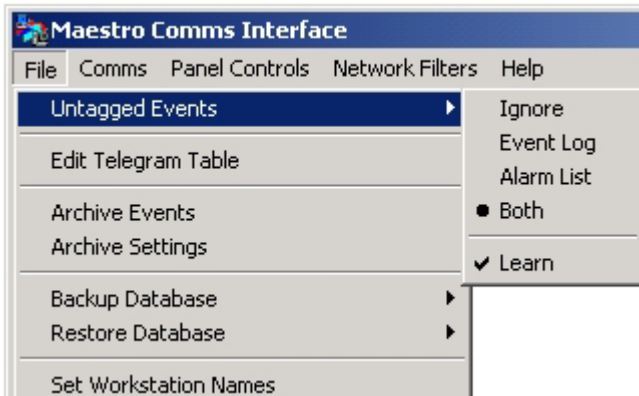

From time to time, especially during the commissioning stages of the fire alarm system installation, there may be devices added and connected to control panels which have not been tagged for incorporation into the MAESTRO system.

The Untagged events menu provides settings to allow MAESTRO to accept or ignore events from such devices.

# Maestro Graphics System

## Maestro Communications Interface

By clicking onto the appropriate heading in the menu list the following settings may be altered.

1. **Ignore.** This selection enables the workstation to ignore any untagged events. MAESTRO will make no reference or record of any event from an untagged source.
2. **Event log.** Events from untagged devices are not displayed in alarm lists, but recorded in the main system event log.
3. **Alarm list.** Events from untagged devices are displayed in alarm lists, but not recorded in the event log.
4. **Both.** Events from untagged devices are displayed in the alarm list and recorded in the event log.
5. **Learn.** The Learn function adds a tag number for the untagged device, based upon the address, loop and zone information obtained from the messages sent to MAESTRO from the panel.

Once learned, the tag number will be shown in all tag lists, alarm lists and event logs. The device will appear with a tag number, panel number, loop number, address zone number, device type (icon) and device message, but no description and location details until these are added into the tag database. Likewise it will not be shown on map displays until it has been placed on the appropriate map in the map database.

### 3.4.1.2. Archive events

The Archive Events button, is used to archive all events in the Current Event Log into the Archive Event Log and for events older than the Archive log size, from the Archive Event Log to daily event files for removal from the system into long term storage.

The total number of items archived is displayed as an event in the Event Log list.

### 3.4.1.3. Archive settings

The operation of the archive file is detailed in Section 8.1.4. of the MAESTRO users guide.

Events are filed on a daily basis.

Time periods for both the Current and Archive event files are set in the Archive settings box. The box is accessed by clicking onto the Archive Settings item.

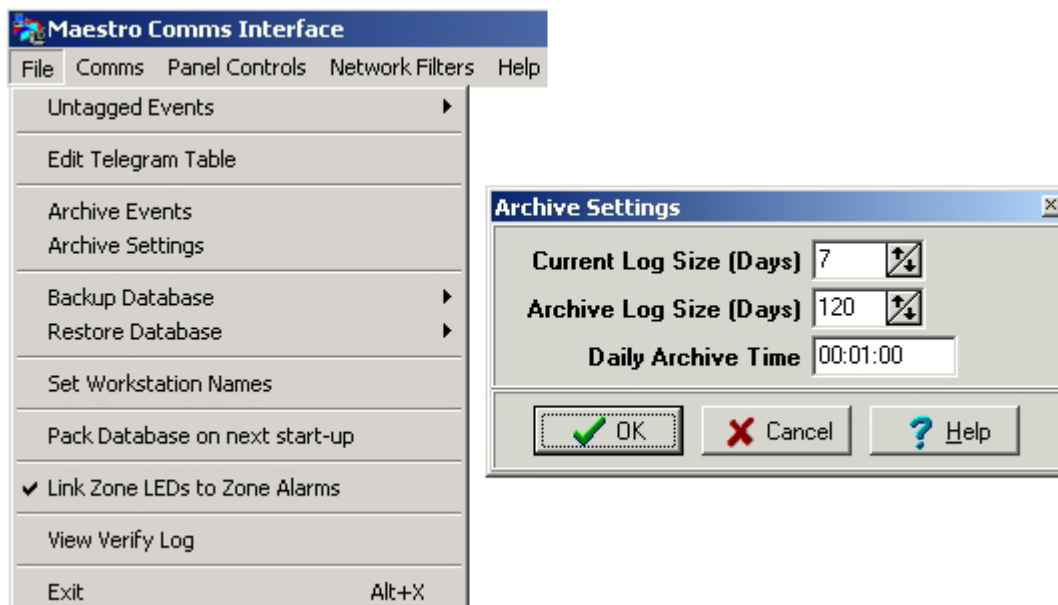

# Maestro Graphics System

## Maestro Communications Interface

The following settings are available -

1. **Current Log Size (Days).** The period for which events stay in the current event file can be set in days, from 1 to 7 days.
2. **Archive Log Size (Days).** The period for which events stay in the archive event file can be set up to a maximum of 180 days and minimum of 7 days. The archive log size minimum setting has been reduced from 30 days to 7 days, thereby minimizing the file size of the archive data file.

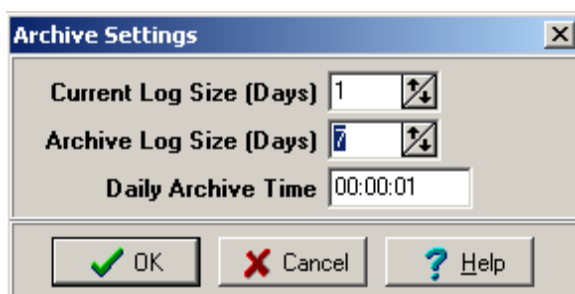

3. **Daily Archive Time.** The time at which current events older than the number of days specified in the Current Log are moved to the Archive Log and from the Archive Log to the daily backup files.

At the time set in the Daily Archive Time, events older than the Archive Log size are automatically moved onto the workstation hard disc. As separate day files they are named and can be accessed by date via a suitable application programme.

The daily files are formatted as Comma (,) Separated Value Text (CSV) files compatible with applications such as MS Excel.

The number of archived day files held on the MAESTRO workstation depends only upon the available hard disc space.

# Maestro Graphics System

## Maestro Communications Interface

### 3.4.1.4. Maestro Backup

- 1.1. This feature is used to backup the current installation of Maestro.
- 1.2. To access this feature navigate to File\Backup Database (commissioning tools).
- 1.3. The user has the option to either backup all the databases or backup selected databases:

- Backup All
- Tag Database
- Map Database
- Panel Database
- Icon Database
- User Database
- Network Database
- Settings Database
- Diagnostic Database
- Events Database

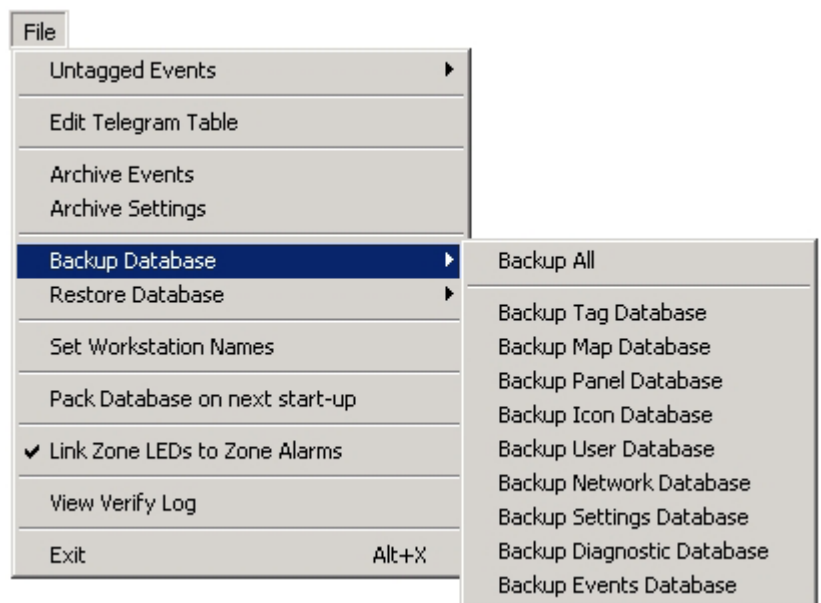

### 3.4.1.5. Maestro Restore

- 2.1. This feature is used to restore a previous installation of Maestro.
- 2.2. To access this feature navigate to File\Restore Database (Commissioning details).
- 2.3. The user has the option to either restore all the databases or to backup selected databases:

- Restore All
- Tag Database
- Map Database
- Panel Database
- Icon Database
- User Database
- Network Database
- Settings Database
- Diagnostic Database
- Events Database

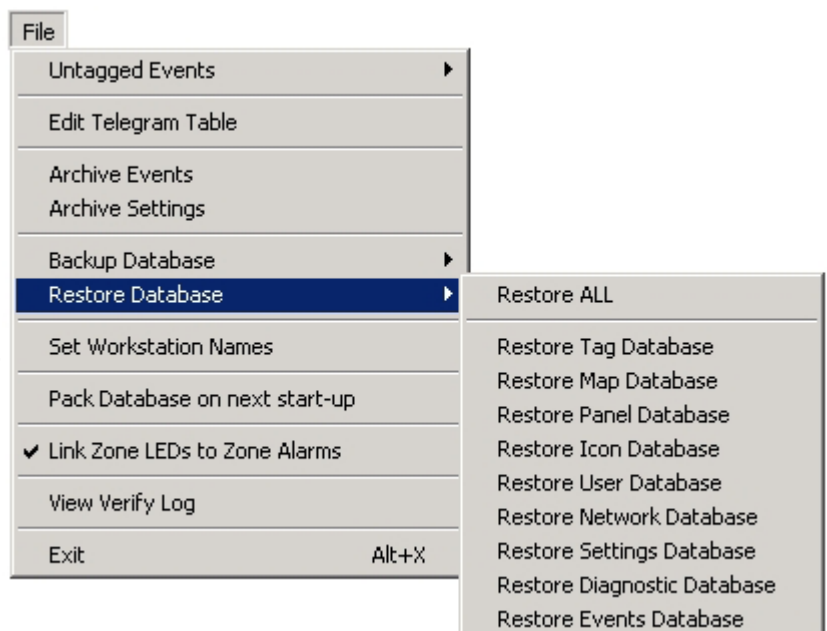

# Maestro Graphics System

## Maestro Communications Interface

### 3.4.1.6. Set workstation names

In client server multi workstation systems, up to five client workstations can be assigned names. Names attributed to workstation locations are shown for each client identification and displayed for that workstation throughout the main MAESTRO programme.

Client Workstation Names are set in the Workstation Names box. The box is accessed by clicking onto the Set Workstation Names item in the File menu and typing in the selected name in the 1 to 5 windows.

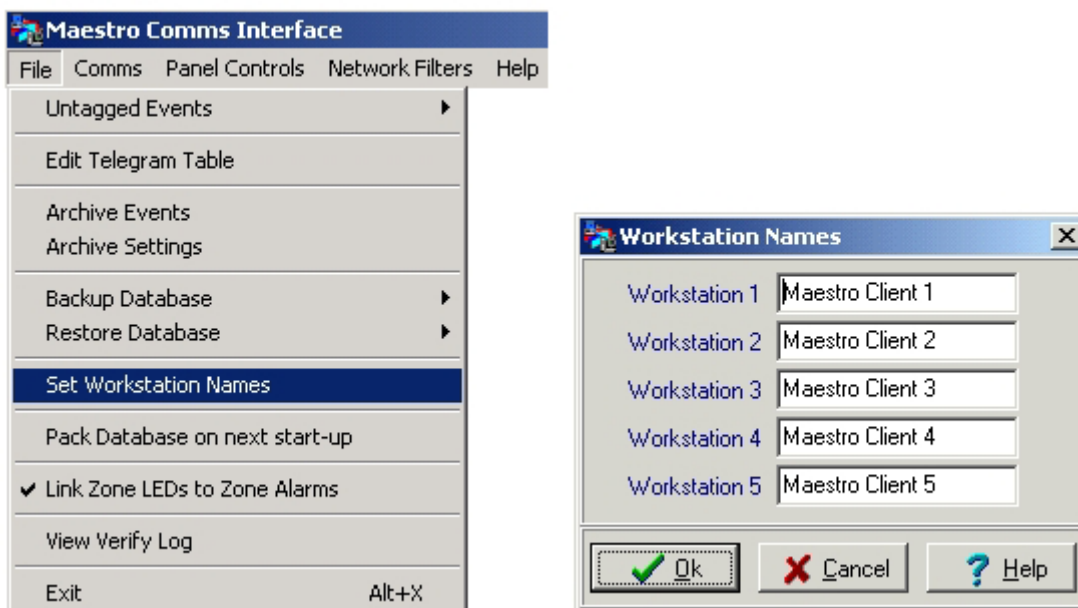

On completion names are saved to the MAESTRO memory by clicking onto the Ok button or left unchanged by clicking onto the Cancel button.

# Maestro Graphics System

## Maestro Communications Interface

### 3.4.1.7. View verify log

On boot up the MAESTRO communications programme checks and verifies all its database files and logs the results to a log file. The listings in the Verify Log can be viewed by clicking onto the View Verify Log item in the File menu. The DB Verify Log box is then displayed.

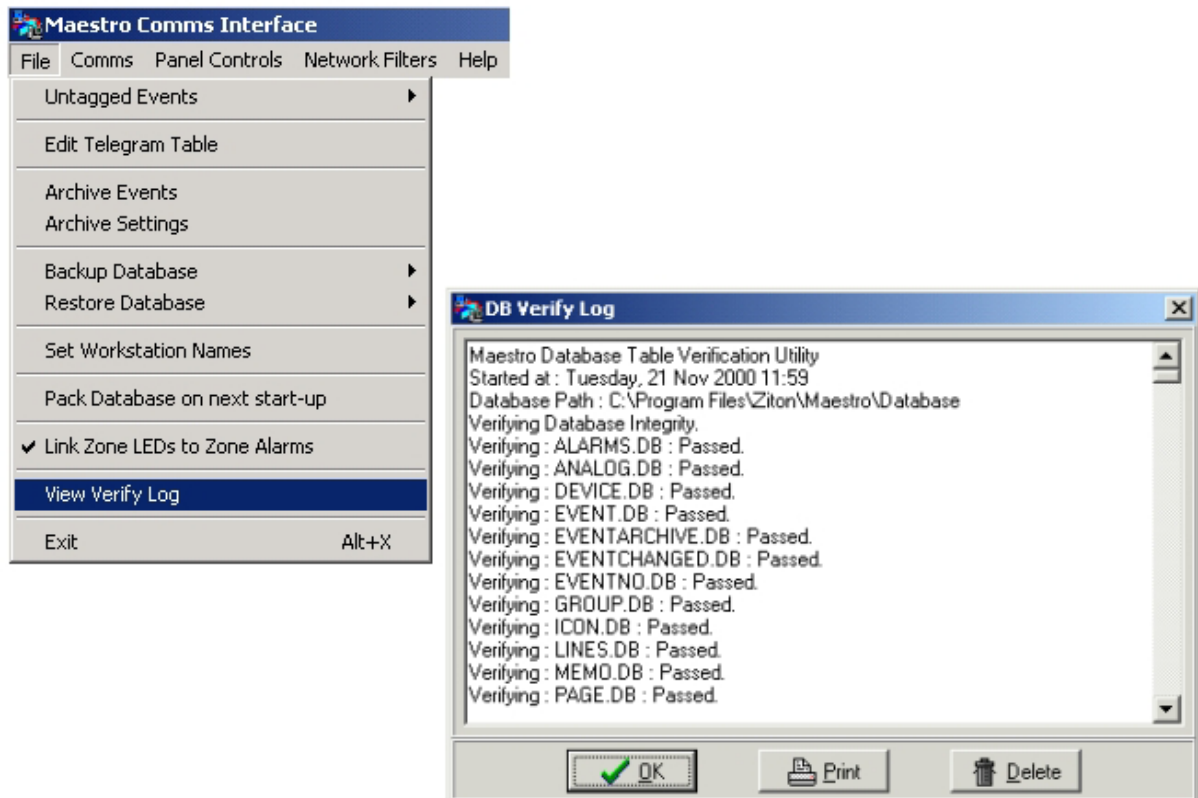

The following functions are provided by clicking onto the appropriate button located at the bottom of the log display -

1. **OK.** Exits the Verify Log display.
2. **Print.** Clicking onto the Print button displays a dialogue box where the log can be printed out in its entirety, or by selected portion, by dragging the cursor across the required entries.
3. **Delete.** Deletes the events display in the Verify Log.

### 3.4.1.8. Exit

Clicking onto to the Exit button exits the communications interface, via a confirmation dialogue box. This button is equivalent to the shutdown button on the main toolbar (Section 3.3).



# Maestro Graphics System

## Maestro Communications Interface

### 3.4.2. Comms

By clicking onto the Comms menu the following functions are accessed.



Clicking onto the Set up Communications item in the Comms menu displays the Set up Communication Channels window.

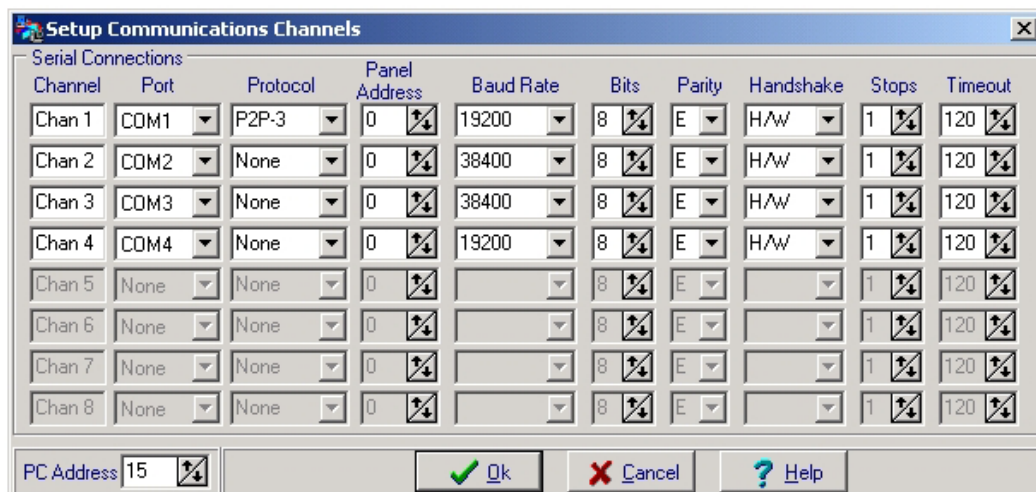

**Communications Channel and Comm Port1.** To permit the use of a maximum of 255 communications ports (for example where Virtual Comm ports are installed), Maestro Ver 3.01 introduces the concept of communication channels which may be allocated to any Comm port required. All panels connected to Maestro are allocated to any one of 8 available channels (in the Network Filters/Configure Panels dialog). A panel may only be assigned to a single channel, but up to 8 simultaneous channels can be used. In the Setup Communications window each channel may then be assigned to a specific Comm port. The settings for each channel must be unique, i.e. the same Comm port may not be assigned to more than one channel at a time. If a channel has to be re-assigned to a different Comm port, this is simply done by reallocating the specific channel to a new Comm port in the Setup Communications window, without needing to alter any network filter settings.

Navigate to Maestro\Comms\Setup Communications

The window allows configuration of the serial connections between the fire detection and alarm system and the MAESTRO workstation. MAESTRO is compatible with both current ZP3 and earlier ZP5 protocols and it is via the Set up Communications Channels window that details of the serial connections are selected.

# Maestro Graphics System

## Maestro Communications Interface

The Set up Communications window comprises eight rows of nine columns. The default state shows the top four rows enabled.

Rows and columns are arranged as follows, all inputs are selected from drop down options -

1. **Comms Port.** This item indicates the comms port on the workstation PC for the fire alarm panel input. Ports one to four are enabled by default. Any row can be enabled or disabled by a right hand click on any window in the selected row. An option box is displayed from which either enable or disable can be chosen.
2. **Protocol.** Protocol is a function of fire alarm control panel type, the following options are displayed by clicking onto the drop down list -
  - None. No protocol selected. Port not in use.
  - P2P. Peer to peer original version. Suitable for ZP3 panels running software prior to version 1.25.
  - P2P-2. Later peer to peer for ZP3 panels. This is the current protocol providing faster communication speeds.
  - P2P-3. Latest peer-to-peer protocol recommended for all new Maestro networks featuring ZP3 panels.
  - ZCP2. Select for ZP5 Mk4 and Mk5 fire alarm control panels.
  - ZCP2V3. This option is not yet available on the ZP3 panel. To be used with a special comms unit for special applications.
  - ZCP1. Select for ZP5 up to and including Mk2 fire alarm control panels.
3. **Panel Address.** This column is for use with ZCP1 and ZCP2 type protocols only. This number is set to the panel number to which the MAESTRO workstation is physically connected.

For systems based on P2P, and P2P-2 type protocols, the workstation panel number is selected via the PC Address window at the bottom left of the Communication Channels window. In the default state, this shows number 64, but can be set to any number from 1 to 64.
4. **Baud Rate.** The operating speed of the workstation must be matched to the output speed of the fire alarm control panel. For most systems operating on P2P-2 protocol, a baud rate of 19200 should be selected from the drop down options list. For ZCP1 and ZCP2 protocols the maximum baud rate is 9600.
5. **Bits.** 7 bit or 8 bit communication must be selected to match the output of the fire alarm control panel. ZP3 systems operating on P2P-2 protocol are set to 8 bit, whereas the ZCP(x) protocols usually use 7 bits per character.
6. **Parity.** The following parity options can be selected from the drop down list -
  - N. No parity setting.
  - E. Even parity setting. This is the default setting selected for all ZP3 systems using either P2P or P2P-2 protocol.
  - O. Odd parity setting.
  - S. Space parity (Not used).
  - M. Mark parity (Not used).

# Maestro Graphics System

## Maestro Communications Interface

7. **Handshake.** The following handshake options can be selected from the drop down list -
  - None. No handshake selected.
  - H/W. This is the default setting selected for all ZP3 systems using P2P or P2P-2 protocol. For ZCP1 and ZCP2 protocol, this setting requires a cable with the appropriate connections to control data flow. Refer to Ziton Publication UD GA280 iss 2 for details.
  - Xon/Xoff. (Not used)
8. **Stops.** The Stop Bit value can be set for either 1 or 2 bits. All MAESTRO systems operating on any protocol should be set to one stop bit.
9. **Time Out.** This is the time period, variable from 0 to 999 seconds, after which the workstation displays the fire alarm control panel as "Off Line", if no communications have been received. The value should be set to 60 seconds. On systems with large number of panels, a time out period of up to 120 seconds may be required. For ZCP1 and ZCP2 protocol the timeout must be at least 120 seconds.

The Set up Communications Channel window is completed with a row of function buttons along the bottom of the display.

1. **PC Address.** Selects the workstation network address number. See 3. above Panel Address.
2. **OK.** Exits the user from the Set up Communications Channel window.
3. **Cancel.** Cancels the changes made in the Set up Communications Channel window returning the display to the default values.
4. **Help.** A left hand click onto the Help button displays a menu providing general help information.

# Maestro Graphics System

## Maestro Communications Interface

### 3.4.2.2. Edit telegram table

The MAESTRO workstation communicates with the fire alarm control panel(s) on a continuous basis. When an event occurs on the fire alarm system the message is sent to the workstation in a shorthand form or telegram. The range of events transmittable by the fire alarm system is listed in the Telegram Table. Within the list each event is assigned a state and a class, dependent upon the type of system (fire, security or general), generating the event.

The Telegram Table Editor enables changes to be made in both state and class of events.

Extreme care must be taken when attempting to modify the Telegram Table as event priorities and system operation will be affected.

The Telegram Table Editor is accessed via the Comms drop down menu. Clicking onto the Edit Telegram Table item displays a warning box emphasizing the seriousness of telegram modification.

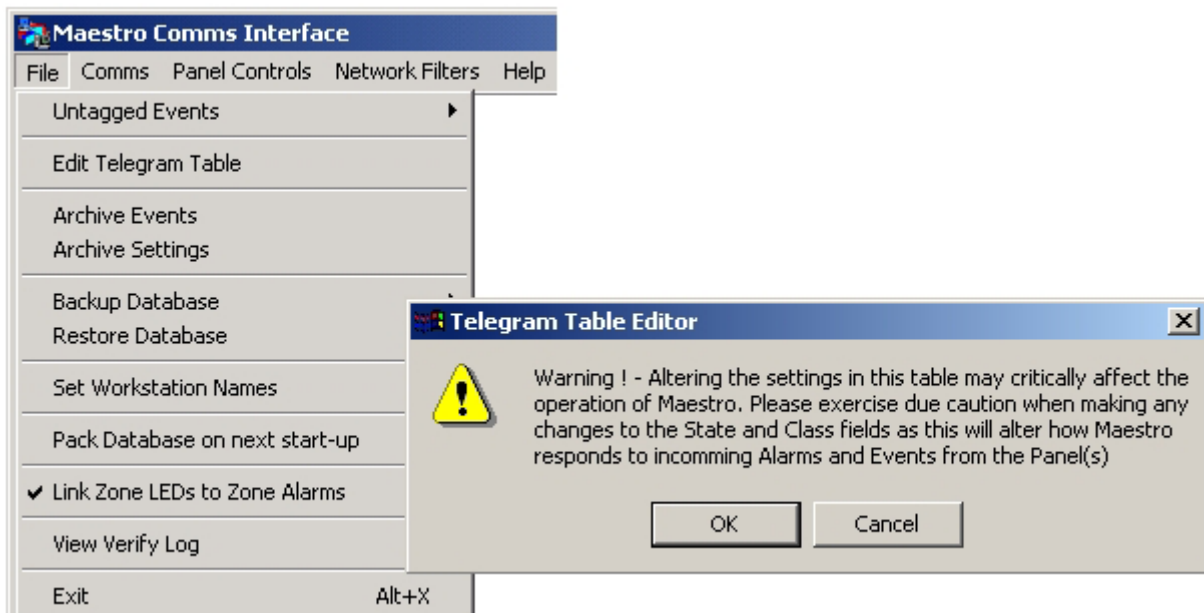

Clicking onto the OK option displays the Telegram Table Editor.

# Maestro Graphics System

## Maestro Communications Interface

The Telegram Table editor has the following fields:

**Telegram:** The telegram code number issued by the panel. At present there are over 130 telegram types.

**State:** Indicates the resultant state for an Icon in response to receipt of the telegram. Typical icon states are 0: Normal, 1: Fire, 2: Pre-Alarm, 3: Service, 4: Fault, 5: Disabled. The number used has a direct bearing upon the Icon displayed in response to the receipt of the telegram.

**Class(Fire):** Indicates the fire alarm class associated with the alarm condition signalled by the telegram. Fire alarm classes are 1: Fire, 2: Pre-Alarm, 3: Faults, 4: Disables, 5: Informational and 6: **Gas Status**. The number entered determines the "alarm bin" into which the alarm will be placed and also the priority of handling the alarm. Of special note is that some entries in this column will have a negative value. This indicates that the condition is an alarm removal (cancellation) from the specified alarm bin.

**Class(Sec):** Indicates the security alarm class associated with the alarm condition signalled by the telegram. Security alarm classes are 1: Alarm, 3: Faults, 4: Disables. Negative values are as described under Class(Fire).

**Class(Gen):** Indicates the general alarm class associated with the alarm condition signalled by the telegram. General alarm classes are 1: Alarm, 3: Faults, 4: Disables. Negative values are as described under Class(Fire).

**Description:** The text description field of the telegram. This description is shown in the alarm banner and also in the alarm list.

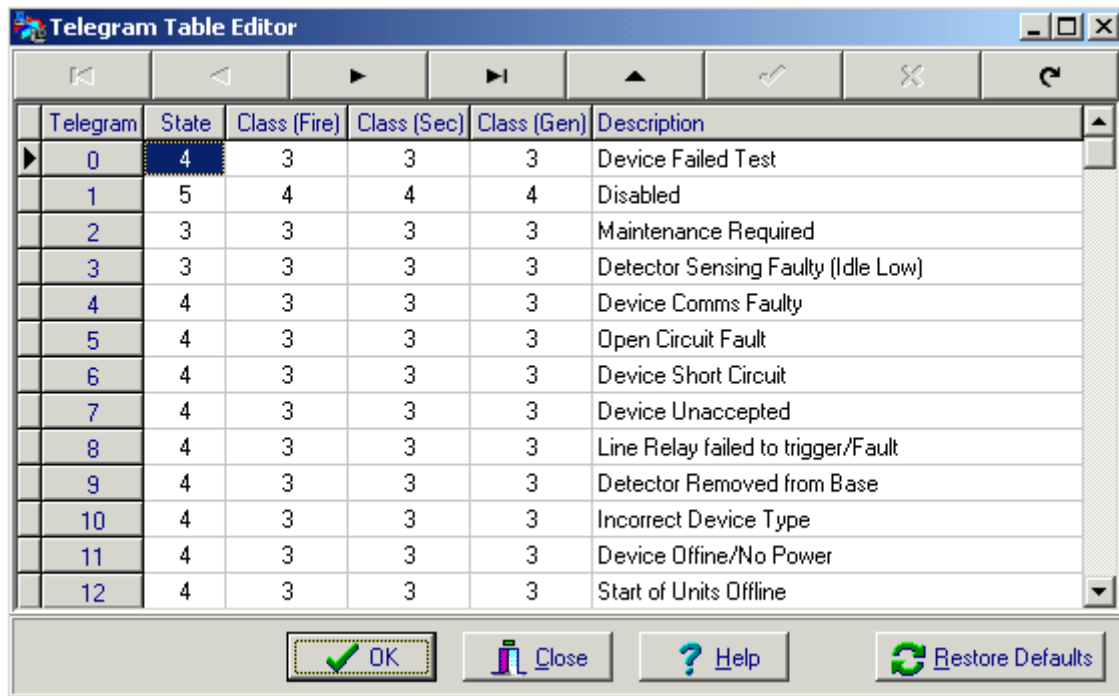

The screenshot shows a window titled "Telegram Table Editor" with a toolbar and a table. The table has columns for Telegram, State, Class (Fire), Class (Sec), Class (Gen), and Description. The data is as follows:

Telegram	State	Class (Fire)	Class (Sec)	Class (Gen)	Description
0	4	3	3	3	Device Failed Test
1	5	4	4	4	Disabled
2	3	3	3	3	Maintenance Required
3	3	3	3	3	Detector Sensing Faulty (Idle Low)
4	4	3	3	3	Device Comms Faulty
5	4	3	3	3	Open Circuit Fault
6	4	3	3	3	Device Short Circuit
7	4	3	3	3	Device Unaccepted
8	4	3	3	3	Line Relay failed to trigger/Fault
9	4	3	3	3	Detector Removed from Base
10	4	3	3	3	Incorrect Device Type
11	4	3	3	3	Device Offline/No Power
12	4	3	3	3	Start of Units Offline

As an example, MAESTRO would respond to Telegram 1, from the above table, in the following manner:

The icon associated with the specific device would be put into state 5 (disabled). The fire alarm class would be 4 (Disables). The alarm banner would state "Device X-X.XXX : Disabled".

# Maestro Graphics System

## Maestro Communications Interface

### 3.4.2.3. Diagnostics

The Diagnostics functions are used in conjunction with the Diagnostics Messages Screen, detailed in Section 3.5.

Clicking onto the Diagnostics item in the Comms menu displays an options list.

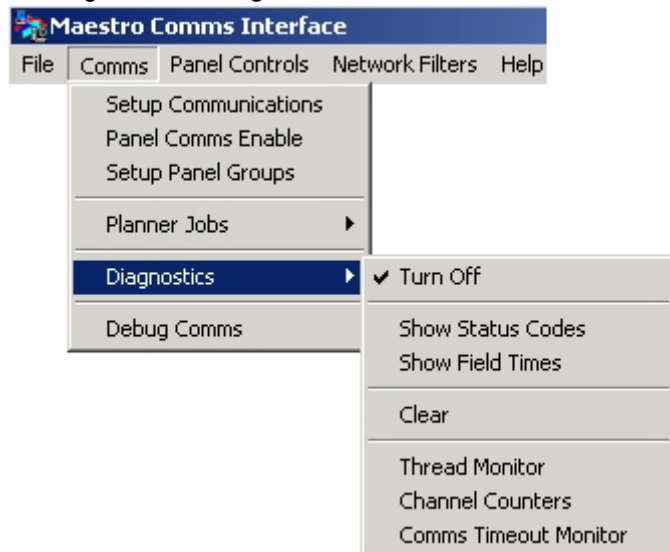

The following functions are accessed by clicking onto the item in the list.

1. **Turn off.** Stops diagnostic messages being displayed on screen.
2. **Show Codes.** Includes Telegram Code in Diagnostic Messages List.
3. **Show Times.** Includes event times in Diagnostic Messages List.
4. **Clear.** Clears all items in Diagnostic List display.

# Maestro Graphics System

## Maestro Communications Interface

### 3.4.2.4. Debug

Selecting the Debug option displays the Debug screen display.

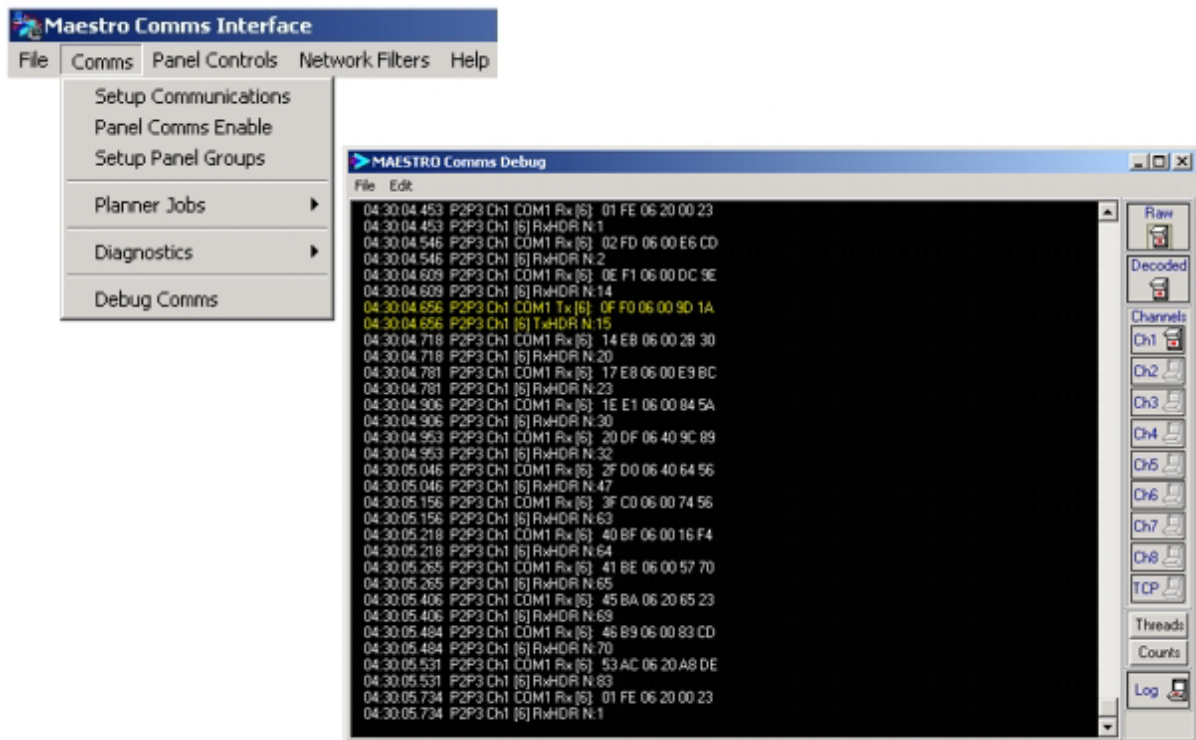

The screen displays the communications messages from panel to workstation and workstation to panel, for the selected channel (as set in the Set up Communication Channel window. Section 3.4.2.1.)

# Maestro Graphics System

## Maestro Communications Interface

An option to view Raw data, Decoded data, or both simultaneously is provided by clicking onto the selection switches located down the right side of the screen display.

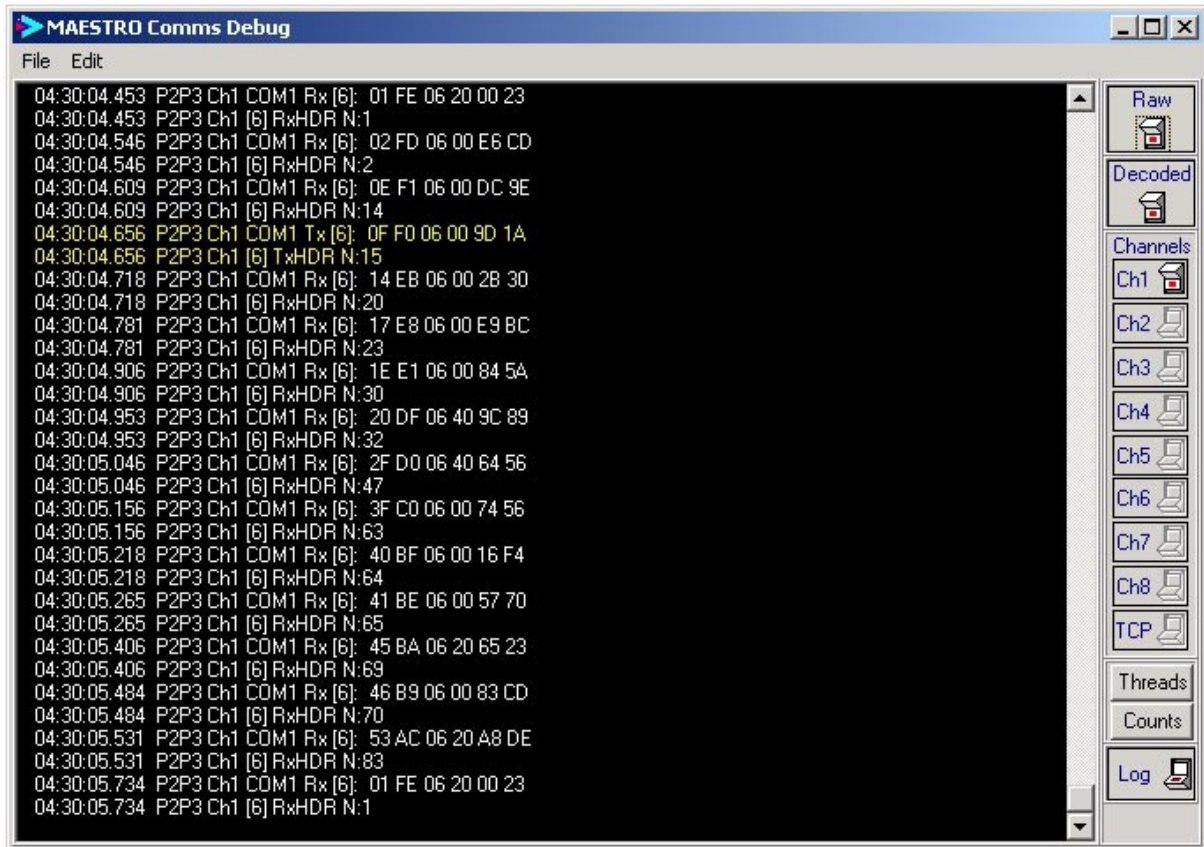

The active channel, or channels in multi channel systems, is shown live in the display of switches from 1 to 8.

The switch option labeled TCP is for future development and currently not operational.

Decoded messages show (from left to right):

[Elapsed time (ms)], TX or RX, the message type, source and target panel numbers and additional detail information (for example priority and packet number).



# Maestro Graphics System

## Maestro Communications Interface

### Comms Channel Counters display

This feature is reserved for engineering diagnostic purposes. The Comms Channel Counters window is accessed via Maestro Comms Interface/Diagnostics/Channel Counters.

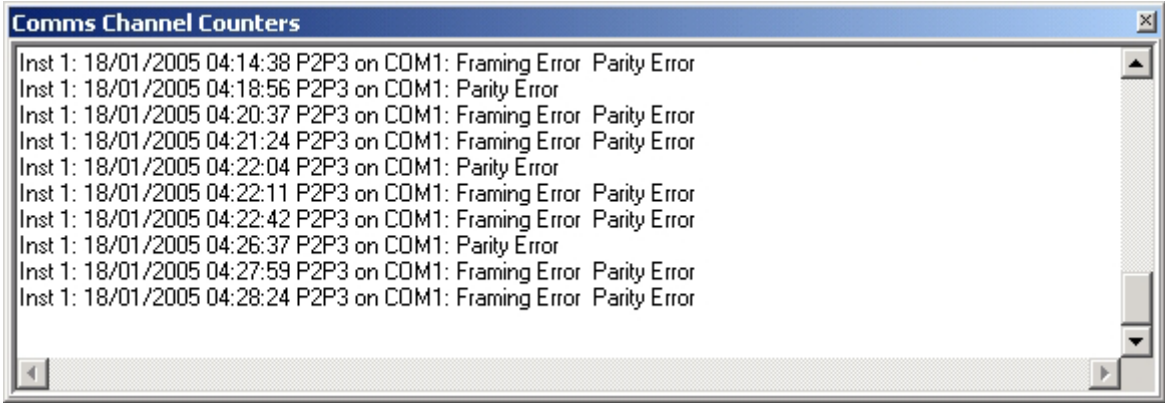

### Threads Monitor

The Threads Monitor window is accessed via the Threads button located at the bottom right of the Debug screen.

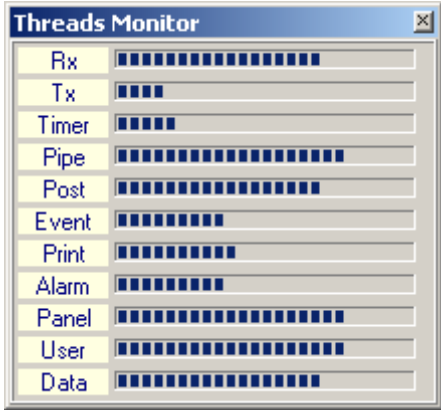

The window monitors activity in various internal operations of MAESTRO Comms and is significant only as far as determining that all internal operations are proceeding normally.

A stationary bar indicates a possible failure in the displayed section of MAESTRO comms. This information is useful to software engineers to assist in determining the cause of any system failures.

# Maestro Graphics System

## Maestro Communications Interface

### 3.4.2.5. Setup of panel groups

With the advent of very large networks, it is likely that individual sections of a network (for example a single building or floor) may need to be controlled independently from other parts of the network. This can be achieved by selecting the required panels to control individually but this is tedious when the system is large. To alleviate the problem, panels may be grouped into any logical association and subsequently controlled as a group. All command actions from Maestro and MaestroComms can now be selected for a pre-defined group.

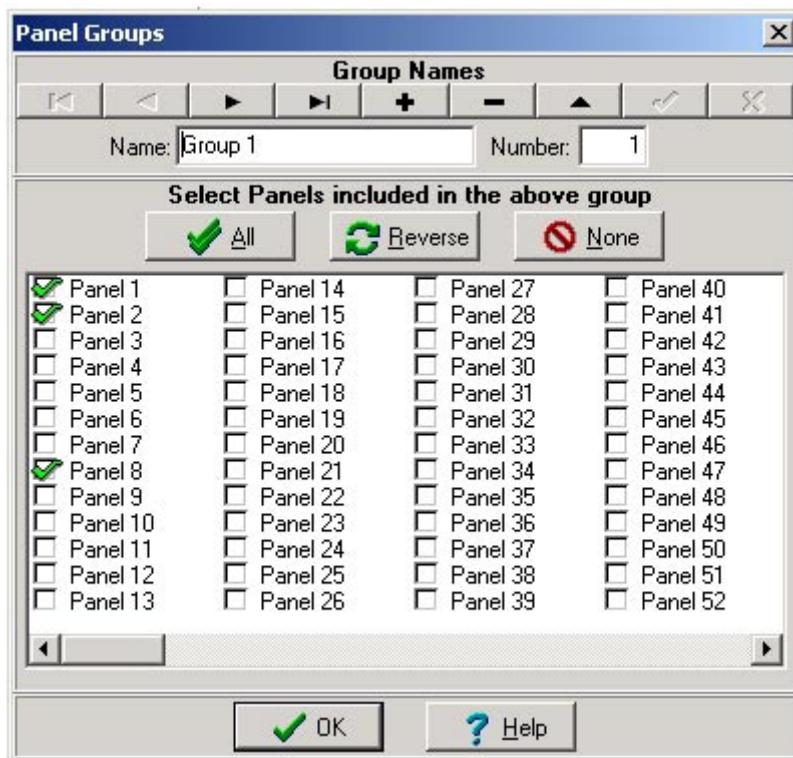

To setup a group, the Panel Groups dialog is opened. Navigate to Maestro Comms\Comms\Setup Panel groups. A name and group number are entered, and the nodes in the group are selected. To save the group, click the "Post" button (shown with a check mark).

# Maestro Graphics System

## Maestro Communications Interface

### 3.4.2.6. Panel Comms Enable

A feature of the Peer to Peer 3 communications protocol is the ability to temporarily disable a panel or group of panels from the communications network for the purpose of carrying out commissioning or testing of a panel. When a panel is comms disabled it does not respond to any events or commands and does not attempt to transmit any of its own messages to any other panel on the network.

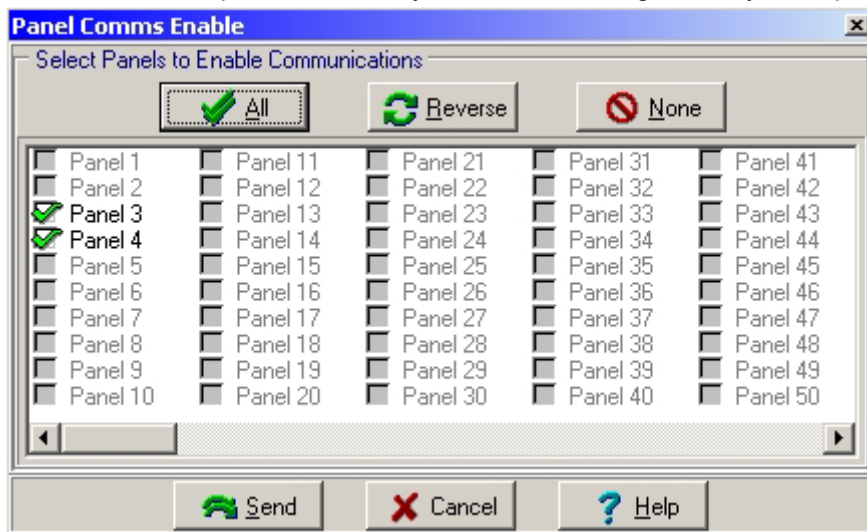

To enable or disable a single or group of panels, open the Panel Comms Enable dialog and select the panel(s) required to be on or off and click the "Send" button. Note that it is necessary to keep a minimum of 2 panels (or a panel and a Maestro) enabled otherwise it will not be possible to recover the network and bring disabled panels back into the network. (If less than two panels are left on this can be done by manually changing the settings of two panels on the network.)

# Maestro Graphics System

## Maestro Communications Interface

### 3.4.3. Panel controls

By clicking onto the Panels Controls menu the following panel and system functions can be accessed via the communication interface display.

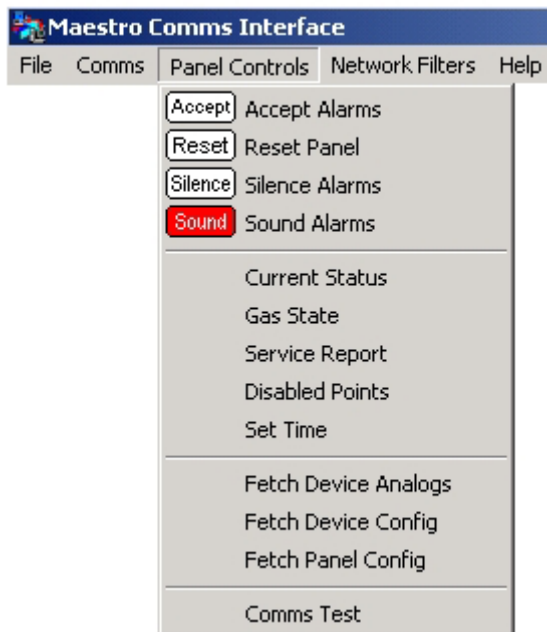

The controls enable commands to be sent to the panel(s), without closing down the communications screens. The top four options, Accept, Reset, Silence Alarms and Sound Alarms provide the same controls as the main buttons displayed on the toolbar and detailed in Section 3.3. paragraph 1.

The second group of four options provide the following functions.

1. **Current Status.** This initiates the requested panel to send the current status of all its devices and zones.
2. **Gas Status.** A request for current information on the gas status of all gas control units to be sent by the panel to MAESTRO.
3. **Service Report.** A request for current information on the service status of all devices to be sent by the panel to MAESTRO.
4. **Disabled Points.** A request for current information on all disabled devices to be sent by the panel to MAESTRO.
5. **Set Time.** This function automatically synchronises the time and date of the fire alarm panel(s) to that of the workstation clock.

The above controls are provided in the communication interface programme to enable the user to conveniently test signals and system status, during initial configuration or subsequent system modification, without having to revert to the main MAESTRO programme.

The same facilities are provided to the workstation operator via zone and device information cards, provided the operator password authority permits access. (See Section 6.3.2. of the MAESTRO User Guide.)

Completing the Panel Controls menu are, Fetch Device Analogues, Fetch Device Configuration and Fetch Panel Configuration. These controls are used to request the panel to send the specified data to MAESTRO Comms for display in the appropriate display window (see Sections 3.6, 3.7 and 3.8).

# Maestro Graphics System

## Maestro Communications Interface

### 3.4.4. Setup panels

Navigate to Maestro Comms interface\Network filters\panels to display Panel Network filters.

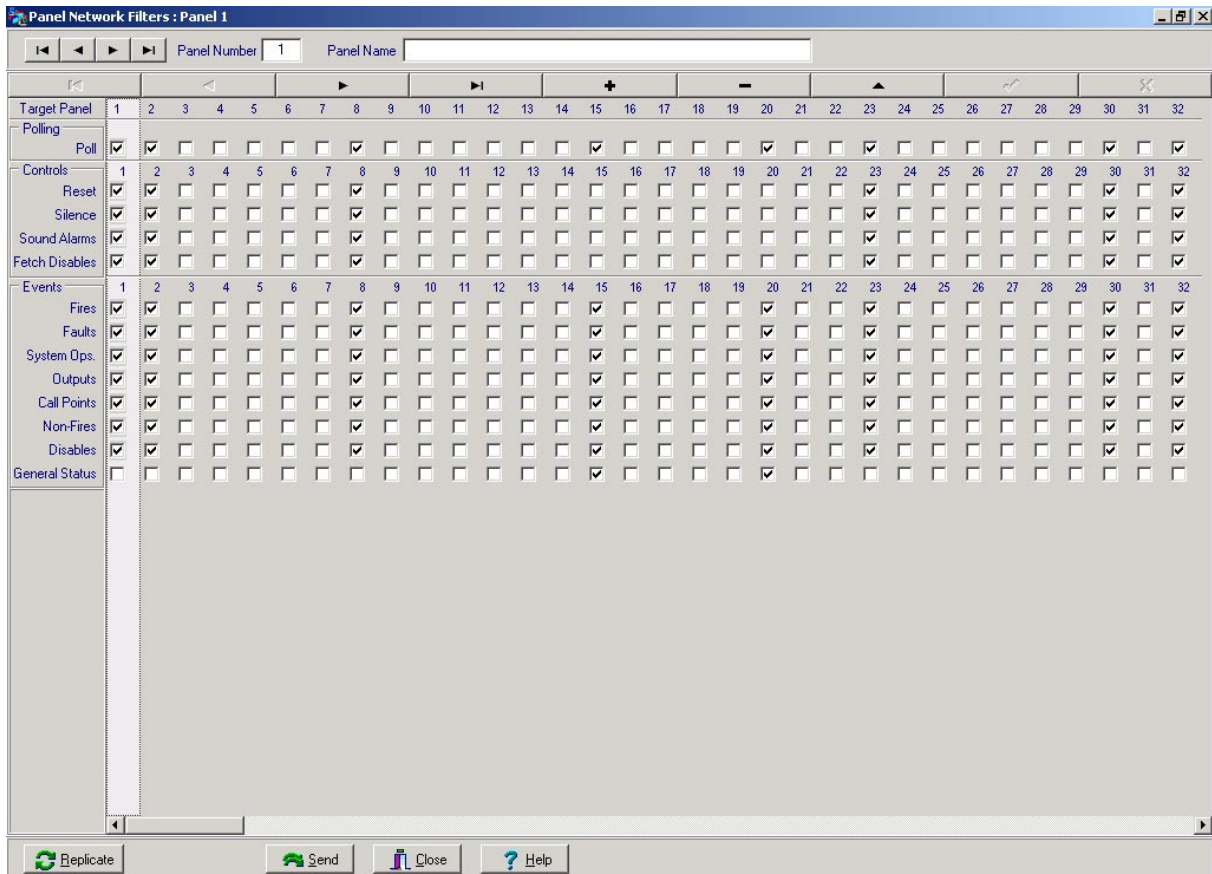

The Configure Panels Window selects which control features, at which panel, are to be operated from the MAESTRO workstation.

If configured at the panel, any of the control functions displayed in the Configure Panels Window can be selected for operation from the MAESTRO workstation.

Selections are automatically registered in the main MAESTRO programme, but these can be modified either globally, or for individual panels via the main Panel Database. (Section 5.4.1.)

Usage: Clear all the selection tick boxes using the 'All off' selection. The selection is done by right clicking on the target panel option for horizontal selections eg. General status. For vertical selections of the individual panels left click on the panel number. This will highlight the column. Right click to select 'All on' or 'All off'.

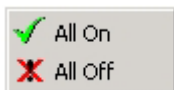

# Maestro Graphics System

## Maestro Communications Interface

The window is divided into four main sections.

1. **Navigation buttons.** At the top of the dialogue window, a set of navigation buttons is provided for moving backwards and forwards through the configurations of up to 64 panels. Once information is complete for the currently displayed panel, it can be posted to the database, or cancelled, by clicking onto the appropriate button.
2. **Panel Identification.** The panel number is selected in the Number window by scrolling from 1 to 64, using the navigation buttons located above. The panel Name is typed into the window provided and the type is selected from the drop down list. The workstation Port is also selected from the drop down list.
3. **Control Filters.** Controls are selected by clicking onto the window of each required control function.
4. **Event Filters.** Events can be filtered by checking each required filter. MAESTRO can emulate a range of devices to provide for remote control of output devices, connected to panels. The event filters control the type of operation permitted by MAESTRO.

The three buttons positioned across the bottom of the window provide the following functions.

1. **OK.** Closes the window.
2. **Cancel.** Cancels the information from the currently displayed panel number.
3. **Help.** A left hand click onto the Help button displays a menu providing general help information.

### Panel Network Filters

Maestro allows for individual panel filters to be configured.

A configured panel filter can be replicated for user selected panels, which can be broadcast on the network using the Maestro Send function.

Once all the tick boxes have been cleared select the desired panel filters. The filters being configured will be the settings for the panel being targeted. ZZZ panel filter controls to Maestro panel terminals must be selected as off while Maestro terminals are the only terminals that have the General status filter selected. Referring to the Panel network filter picture, panel 15 and panel 20 are the Maestro terminals.

### Panel replicate feature

Select the panels that have the same filter settings in the replicate window. Click on the send button to transmit the panel filters onto the network. Depending on the site configuration, panel groups can be taken into consideration when these selections are being made.

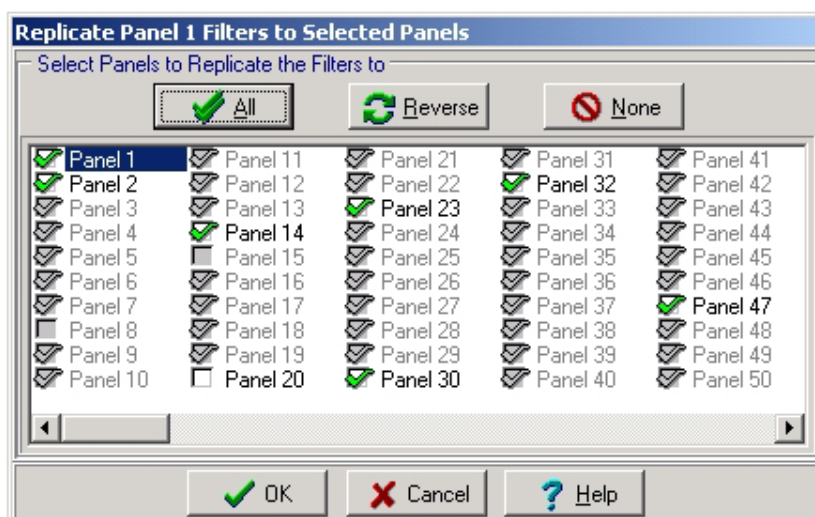

# Maestro Graphics System

## Maestro Communications Interface

### 3.5. Diagnostic messages screen

The Diagnostic Messages Screen is the default screen shown when the communications interface is booted up. The screen displays all event messages between the MAESTRO workstation and the fire alarm system control panel(s) including applicable diagnostic messages. All system event messages are also recorded simultaneously in the MAESTRO Event Log.

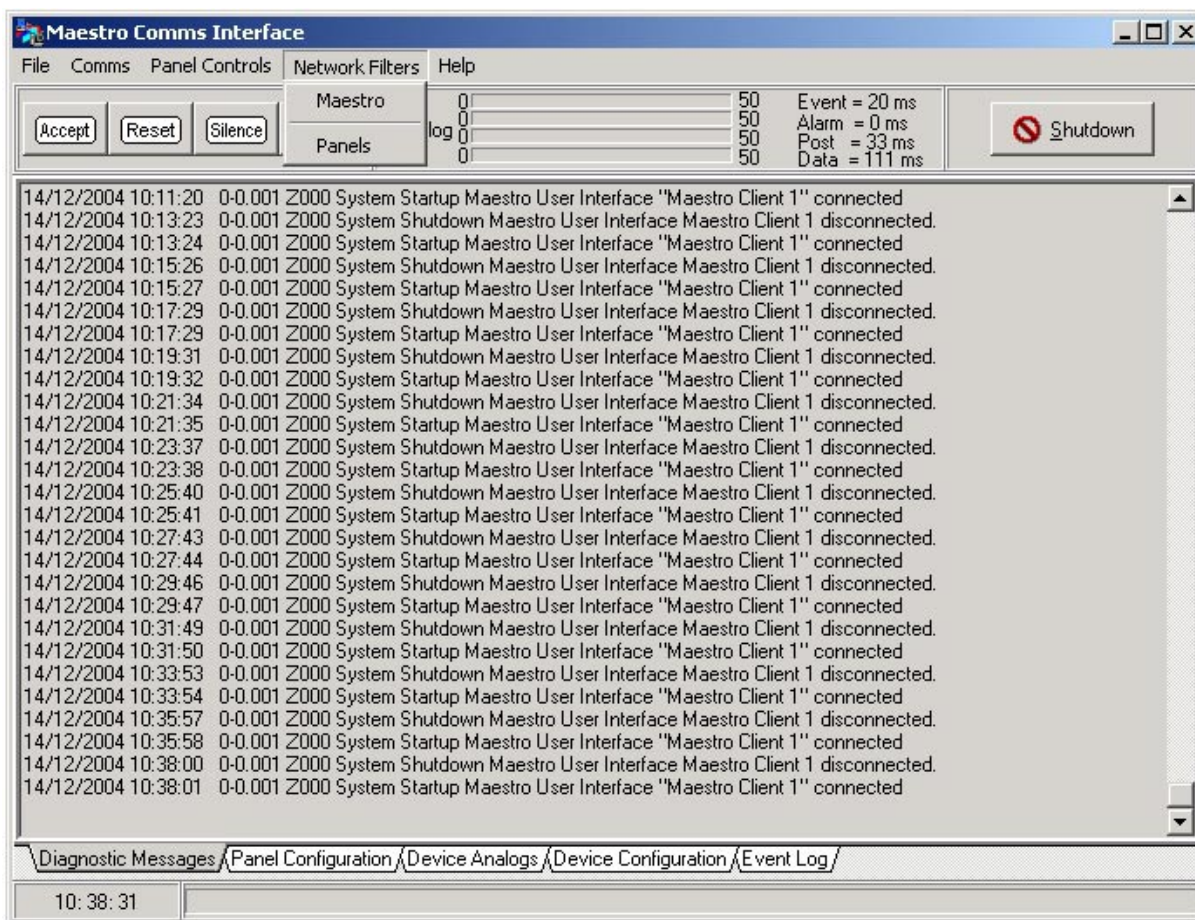

All event and Comms messages received and transmitted by the workstation are added to the messages list.

The list displays each Comms message by Date, Time, Comms Port and relevant description (taken from information held in the main databases and the Comms interface).

The Diagnostic Messages listing displayed on the screen can be copied to the Windows Clip Board facility and reproduced by downloading into an appropriate application.

Accessing the Diagnostics menu enables some editing of the message detail. (Section 3.4.2.3.)

Any of the other Communication Interface display screens may be accessed by clicking onto the appropriate screen tab at the bottom of the display.

# Maestro Graphics System

## Maestro Communications Interface

### 3.6. Panel configuration screen

This display shows the configuration of each panel in the fire alarm system. The panel settings displayed are for user information, and are retrieved from the relevant panel. The actual settings in the panel(s) cannot be changed by this screen.

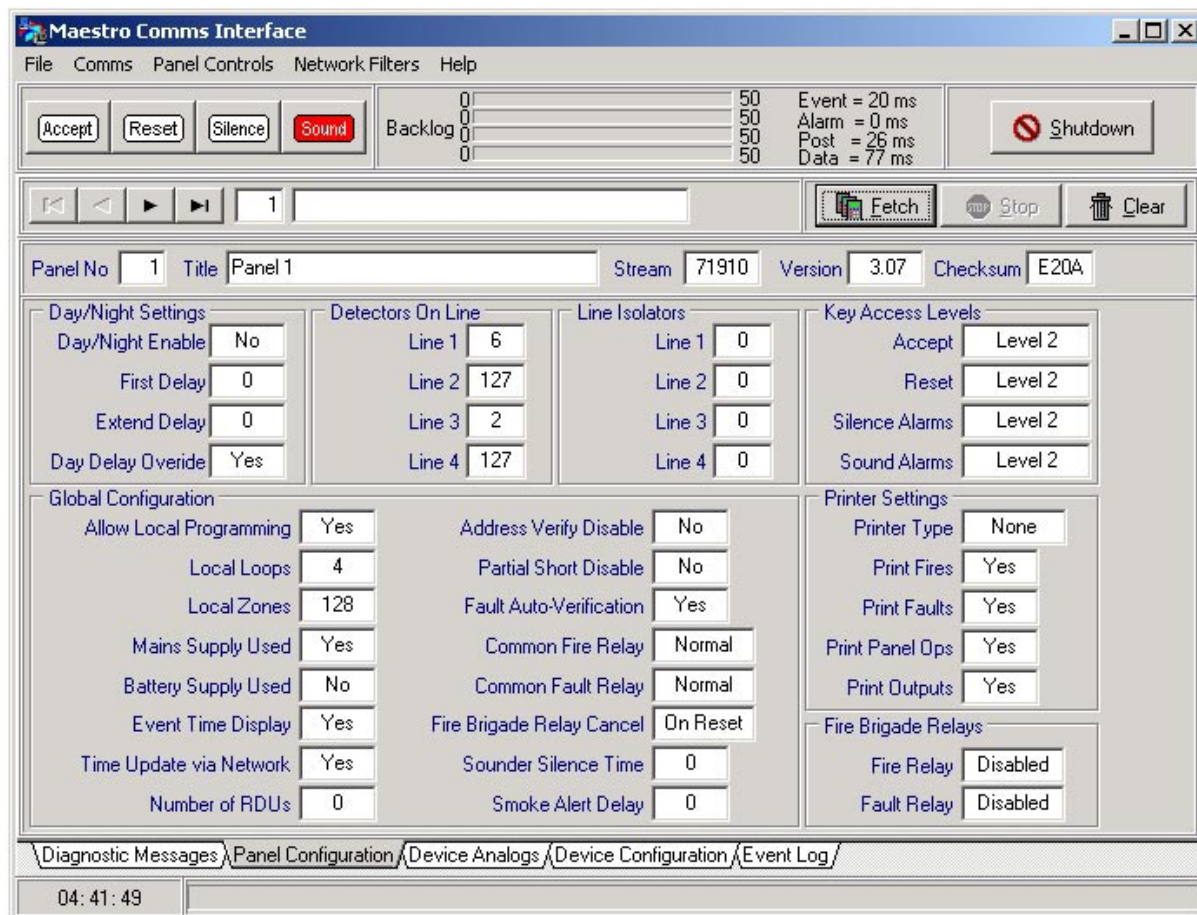

The display enables the commissioning engineer or user to see immediately full details of each panel connected to the MAESTRO system.

Information is collected into the following groups.

1. **Panel number, title and software details.** This area provides general information on the panel number in the network, from 1 to 64, the title or name of the panel and details of the software stream, software version and checksum value.
2. **Day/night settings.** Confirms the day/night setup for the particular panel and lists time delays and overrides.
3. **Detectors on line.** Displays the total sensors connected to each loop or line of the displayed panel.



# Maestro Graphics System

## Maestro Communications Interface

4. **Line isolators.** Shows the total of short circuit loop or line isolators, protecting each panel loop.
5. **Key access levels.** The status of the major control settings is displayed for the panel being viewed.
6. **Global configuration.** Confirms the main panel configurations, as a part of the overall fire alarm system network. Listings include panel loop inputs, remote outputs, sensor delays and alarm verifications.
7. **Printer settings.** Confirms the printer type the MAESTRO system is connected to and the main alarm filters applied to the particular control panel.
8. **Fire brigade relays.** Shows the settings for both fire and fault Remote Manned Centre outputs.

Provision is made across the top of the screen for scrolling numerically through all panels connected to the MAESTRO system. The panel number and name are displayed for each panel screen.

### 3.6.1. Fetch new panel data box

Positioned at the top right of the screen are three display controls.

1. **Fetch button.** To display the required information, it must first be "fetched" from the relevant panel. Clicking onto the control located at the top right of the screen, displays the Fetch New Panel Data box, where the required panel number can be selected. Left hand click on the OK button commands the panel to send the requested data.

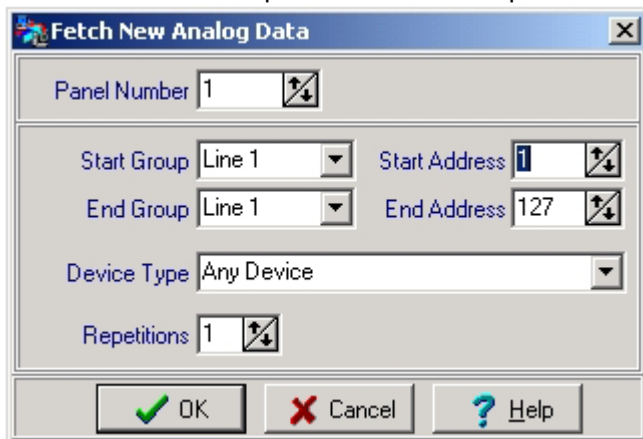

2. **Stop button.** Stops the 'fetch' of information.
3. **Clear button.** Clears the current screen.

Any of the other Communication Interface display screens may be accessed by clicking onto the appropriate screen tab at the bottom of the display.

# Maestro Graphics System

## Maestro Communications Interface

### 3.7. Device analogs screen

This display provides a view of all sensor analogue values, their alarm level settings, thresholds and sensitivities.

The display is accessed by clicking onto the Device Analogues tab at the bottom of the screen.

The screenshot shows the Maestro Comms Interface window. At the top, there is a menu bar with 'File', 'Comms', 'Panel Controls', 'Network Filters', and 'Help'. Below the menu bar are several control buttons: 'Accept', 'Reset', 'Silence', and 'Sound'. To the right of these buttons is a 'Backlog' section with numerical values (0, 50, 50, 50) and a 'Shutdown' button. Below the control buttons is a 'Fetch' button, a 'Stop' button, and a 'Clear' button. The main area of the window is a table with columns for 'Addr', 'Device Type', 'Zone', 'Status', 'Ref', 'Grp', 'Dev', 'Zero', 'Pri', 'Sec', 'Alarm', 'PreAlm', 'SensPri', 'SensS...', 'ThresPri', 'ThresSec', and 'Time'. The table contains 26 rows of data, all with a green background. The status column for all rows is 'Normal'. The time column shows '25/01/2005 04:45:39'. At the bottom of the window, there is a status bar with the text 'Diagnostic Messages / Panel Configuration / Device Analogues / Device Configuration / Event Log /' and a timestamp '04:46:44'.

Addr	Device Type	Zone	Status	Ref	Grp	Dev	Zero	Pri	Sec	Alarm	PreAlm	SensPri	SensS...	ThresPri	ThresSec	Time
1001	Ionization	0	Normal	215	247	215	0	68	0	134	127	Normal	Normal	134	255	25/01/2005 04:45:39
1002	Ionization	0	Normal	215	246	215	0	68	0	134	127	Normal	Normal	134	255	25/01/2005 04:45:39
1003	Ionization	0	Normal	215	246	214	0	68	0	134	127	Normal	Normal	134	255	25/01/2005 04:45:39
1004	Ionization	0	Normal	214	246	214	0	68	0	134	127	Normal	Normal	134	255	25/01/2005 04:45:39
1005	Ionization	0	Normal	214	246	214	0	68	0	134	127	Normal	Normal	134	255	25/01/2005 04:45:39
1006	Ionization	0	Normal	214	246	214	0	68	0	134	127	Normal	Normal	134	255	25/01/2005 04:45:39
1007	Ionization	0	Normal	214	246	214	0	68	0	134	127	Normal	Normal	134	255	25/01/2005 04:45:39
1008	Ionization	0	Normal	214	246	214	0	68	0	134	127	Normal	Normal	134	255	25/01/2005 04:45:39
1009	Ionization	0	Normal	214	246	214	0	68	0	134	127	Normal	Normal	134	255	25/01/2005 04:45:39
1010	Ionization	0	Normal	214	246	214	0	68	0	134	127	Normal	Normal	134	255	25/01/2005 04:45:39
1011	Ionization	0	Normal	214	246	214	0	68	0	134	127	Normal	Normal	134	255	25/01/2005 04:45:39
1012	Ionization	0	Normal	214	246	214	0	68	0	134	127	Normal	Normal	134	255	25/01/2005 04:45:39
1013	Ionization	0	Normal	214	246	214	0	68	0	134	127	Normal	Normal	134	255	25/01/2005 04:45:39
1014	Ionization	0	Normal	214	246	214	0	68	0	134	127	Normal	Normal	134	255	25/01/2005 04:45:39
1015	Ionization	0	Normal	214	245	214	0	68	0	134	127	Normal	Normal	134	255	25/01/2005 04:45:39
1016	Ionization	0	Normal	214	245	214	0	68	0	134	127	Normal	Normal	134	255	25/01/2005 04:45:39
1017	Ionization	0	Normal	214	246	214	0	68	0	134	127	Normal	Normal	134	255	25/01/2005 04:45:39
1018	Ionization	0	Normal	214	246	214	0	68	0	134	127	Normal	Normal	134	255	25/01/2005 04:45:39
1019	Ionization	0	Normal	214	246	214	0	68	0	134	127	Normal	Normal	134	255	25/01/2005 04:45:39
1020	Ionization	0	Normal	214	246	214	0	68	0	134	127	Normal	Normal	134	255	25/01/2005 04:45:39
1021	Ionization	0	Normal	214	246	214	0	68	0	134	127	Normal	Normal	134	255	25/01/2005 04:45:39
1022	Ionization	0	Normal	214	246	214	0	68	0	134	127	Normal	Normal	134	255	25/01/2005 04:45:39
1023	Ionization	0	Normal	214	245	214	0	68	0	134	127	Normal	Normal	134	255	25/01/2005 04:45:39
1024	Ionization	0	Normal	214	246	214	0	68	0	134	127	Normal	Normal	134	255	25/01/2005 04:45:39
1025	Ionization	0	Normal	214	246	214	0	68	0	134	127	Normal	Normal	134	255	25/01/2005 04:45:39
1026	Ionization	0	Normal	214	246	214	0	68	0	134	127	Normal	Normal	134	255	25/01/2005 04:45:39

A separate screen is provided for each panel loop. Clicking onto the Line tabs located at the top left of the display, shows a listing of all devices connected to the selected loop.

Information is provided in a spreadsheet format. A line for each device, colour coded to the current device state and columns for specific analogue values. Rows and columns can be scrolled by the horizontal and vertical scroll bars located at the bottom and right edges of the screen display.

Each device address occupies a separate row. Unassigned addresses are shown as 'Not Specified', have default values in each cell and the row shown with a grey coloured background.

# Maestro Graphics System

## Maestro Communications Interface

The columns provide the following information.

1. **Address Pointer.** The address pointer runs down the left side of the display. Clicking onto any cell in the spreadsheet lines the pointer adjacent to the selected address.
2. **Address (Addr).** The address number of the device on the loop. The first digit identifies the loop number, with the next three digits forming the device address, between 001 and 127.
3. **Device Type.** The type of device connected to the loop. Unassigned addresses display a 'Not Specified' title.
4. **Zone.** The zone of the fire alarm system in the building where the device is installed.
5. **Status.** The status or alarm state which the device is currently in. The background colour of the address row is colour coded to the alarm state.
6. **Reference (Ref), Group (Grp) and Device (Dev) Analogue Values.** The first three columns display analogue values from which the panel identifies the device type and confirms that the device is connected and on line.
7. **Zero.** Under normal operating conditions a zero value is shown for the device in this column. Values occurring in the Zero column are often used for device or line fault diagnosis.
8. **Primary (Pri).** This is the device analogue level and is a function of the measured variable sensed by the detector, for example the level of smoke in the sensor chamber or the temperature sensed by the thermistor of an heat sensor.  
  
The panel uses this varying value to measure and evaluate sensor signals, prior to initiation of alarm procedures.
9. **Secondary (Sec).** Where additional analogue information is available, for example in multi sensing devices, or where other sensor values need to be transmitted to the panel for fault monitoring, an analogue value appears in the secondary column.  
  
The value shown in the secondary column for most devices will be zero.
10. **Alarm.** The analogue threshold, above which the panel commences alarm procedures.
11. **Pre-alarm (PreAlm).** The analogue threshold, above which the panel indicates the device is in a pre-alarm condition, for devices with pre-alarm capability.
12. **Sensitivity Primary (SensPri).** Defines the device sensitivity setting of the primary sensing element.
13. **Sensitivity Secondary (SensSec).** Defines the device sensitivity setting of the secondary sensing element.
14. **Threshold Primary (ThresPri).** Corresponds to the primary alarm threshold setting, but may be adjusted to cater for special fire algorithms.
15. **Threshold Secondary (ThresSec).** Corresponds to the secondary alarm threshold setting, but may be adjusted to cater for special fire algorithms.
16. **Time.** The panel time stamp, when the information was received.

# Maestro Graphics System

## Maestro Communications Interface

Up to 64 panel spreadsheets can be scrolled by the navigation buttons positioned at the top right of the screen display. The selected panel number and name is displayed in the windows adjacent to the navigation buttons.

### 3.7.1. Fetch new analogue data box

The device analogue screens are not automatically updated by the panel. Information is "fetched"; by clicking onto the Fetch button located at the top right of the screen display.

By operating the button the Fetch New Analog Data box is displayed.

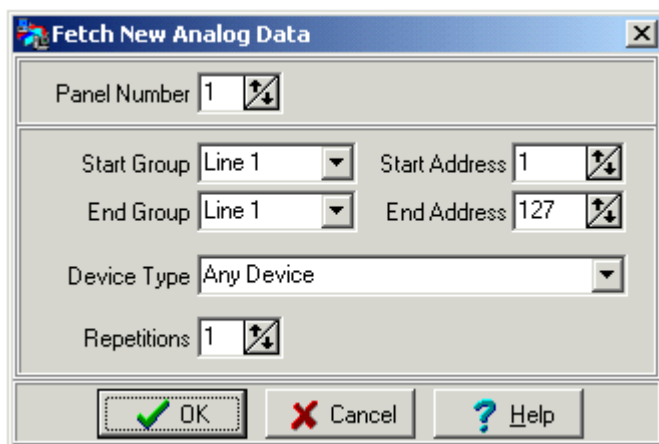

The box provides the following functions.

1. **Panel Number.** By clicking onto the panel numbers any control panel between 1 and 64 can be selected. Upon selection the panel number and name appear in the windows at the top left of the screen display.
2. **Start Group and End Group Windows.** Selects which loops the new information will start from and end at.
3. **Start Address and End Address.** Selects which addresses the new information will start from and end at.
4. **Device Type.** Selects new information from all devices, or filters information by a particular device type only.
5. **Repetitions.** The number of times requested information is to be sent by the panel. Selecting a number of 255 indicates to repeat indefinitely until a stop command is issued.

A timing bar along the top of the main screen indicates the progress during new information 'fetches'.

# Maestro Graphics System

## Maestro Communications Interface

The three buttons positioned across the bottom of the window provide the following functions.

1. **OK.** Issues the command to fetch the requested information and closes the window.
2. **Cancel.** Cancels the command and clears the window.
3. **Help.** A left hand click onto the Help button displays a menu providing general help information.

During any new information fetch, the operation can be either stopped, or the screen cleared, by clicking onto the Stop or Clear buttons located next to the Fetch button at the top right of the main screen display.

Any of the other Communication Interface display screens may be accessed by clicking onto the appropriate screen tab at the bottom of the display.

### 3.8. Device configuration screen

This display provides information on all sensor configurations, their day and night sensitivities, automatic test and alarm functions and where applicable, multi sensor profiles.

The display is accessed by clicking onto the Device Configuration tab at the bottom of the screen.

Addr	Device Type	Zone	Addr Grp	D/Sens I	N/Sens I	D/Sens N	N/Sens N	Sounder	AVF	Self Test	Smk Alert	D/Profile	N/Profile	Sndr Grp	Smoke	Time Star
1001	Iorization	0	0	Normal	Normal	Normal	Normal	No	No	No	No			0	0	25/01/2005 04:
1002	Iorization	0	0	Normal	Normal	Normal	Normal	No	No	No	No			0	0	25/01/2005 04:
1003	Iorization	0	0	Normal	Normal	Normal	Normal	No	No	No	No			0	0	25/01/2005 04:
1004	Iorization	0	0	Normal	Normal	Normal	Normal	No	No	No	No			0	0	25/01/2005 04:
1005	Iorization	0	0	Normal	Normal	Normal	Normal	No	No	No	No			0	0	25/01/2005 04:
1006	Iorization	0	0	Normal	Normal	Normal	Normal	No	No	No	No			0	0	25/01/2005 04:
1007	Iorization	0	0	Normal	Normal	Normal	Normal	No	No	No	No			0	0	25/01/2005 04:
1008	Iorization	0	0	Normal	Normal	Normal	Normal	No	No	No	No			0	0	25/01/2005 04:
1009	Iorization	0	0	Normal	Normal	Normal	Normal	No	No	No	No			0	0	25/01/2005 04:
1010	Iorization	0	0	Normal	Normal	Normal	Normal	No	No	No	No			0	0	25/01/2005 04:
1011	Iorization	0	0	Normal	Normal	Normal	Normal	No	No	No	No			0	0	25/01/2005 04:
1012	Iorization	0	0	Normal	Normal	Normal	Normal	No	No	No	No			0	0	25/01/2005 04:
1013	Iorization	0	0	Normal	Normal	Normal	Normal	No	No	No	No			0	0	25/01/2005 04:
1014	Iorization	0	0	Normal	Normal	Normal	Normal	No	No	No	No			0	0	25/01/2005 04:
1015	Iorization	0	0	Normal	Normal	Normal	Normal	No	No	No	No			0	0	25/01/2005 04:
1016	Iorization	0	0	Normal	Normal	Normal	Normal	No	No	No	No			0	0	25/01/2005 04:
1017	Iorization	0	0	Normal	Normal	Normal	Normal	No	No	No	No			0	0	25/01/2005 04:
1018	Iorization	0	0	Normal	Normal	Normal	Normal	No	No	No	No			0	0	25/01/2005 04:
1019	Iorization	0	0	Normal	Normal	Normal	Normal	No	No	No	No			0	0	25/01/2005 04:
1020	Iorization	0	0	Normal	Normal	Normal	Normal	No	No	No	No			0	0	25/01/2005 04:
1021	Iorization	0	0	Normal	Normal	Normal	Normal	No	No	No	No			0	0	25/01/2005 04:
1022	Iorization	0	0	Normal	Normal	Normal	Normal	No	No	No	No			0	0	25/01/2005 04:
1023	Iorization	0	0	Normal	Normal	Normal	Normal	No	No	No	No			0	0	25/01/2005 04:
1024	Iorization	0	0	Normal	Normal	Normal	Normal	No	No	No	No			0	0	25/01/2005 04:
1025	Iorization	0	0	Normal	Normal	Normal	Normal	No	No	No	No			0	0	25/01/2005 04:
1026	Iorization	0	0	Normal	Normal	Normal	Normal	No	No	No	No			0	0	25/01/2005 04:

# Maestro Graphics System

## Maestro Communications Interface

A separate screen is provided for each panel loop. Clicking onto the Line tabs located at the top left of the display, shows a listing of all devices connected to the selected loop.

Information is provided in a spreadsheet format. A line for each device, with the address and device type backgrounds colour coded to the current device state and columns for specific device configurations. Rows and columns can be scrolled by the horizontal and vertical scroll bars located at the bottom and right edges of the screen display.

Each device address occupies a separate row. Unassigned addresses are shown as 'Not Specified', have default values in each cell and the address and device type shown with a grey coloured background

The columns provide the following information.

1. **Address Pointer.** The address pointer runs down the left side of the display. Clicking onto any cell in the spreadsheet lines the pointer adjacent to the selected address.
2. **Address (Addr).** The address number of the device on the loop. The first digit identifies the loop number, with the next three digits forming the device address, between 001 and 127.
3. **Device Type.** The type of device connected to the loop. Unassigned addresses display a 'Not Specified' title.
4. **Zone.** The zone of the fire alarm system in the building where the device is installed.
5. **Address Group (Addr Grp).** Specifies the group number which the device is in. This number is determined by the number and location of the loop isolators.
6. **Day/Sensitivity 1 (D/Sens 1) and Night/Sensitivity 1 (N/Sens 1).** These are the sensitivity settings in day and night mode respectively for the primary analogue reading.
7. **Day/Sensitivity 2 (D/Sens 11) and Night/Sensitivity 2 (N/Sens 11).** These are the sensitivity settings in day and night mode respectively for the secondary analogue reading.
8. **Sounder.** The column confirms if the device is a loop wired, addressable sounder, or is fitted to a sounder base.
9. **Alarm Verification (AVF).** The column confirms if the device is subject to an alarm verification, prior to the panel commencing alarm procedures.
10. **Self Test.** The column confirms if the automatic self test function is currently in operation.
11. **Smoke Alert (Smoke Alert).** The column confirms if the smoke alert function is applied to the device address.
12. **Day Profile (D/Profile) and Night Profile (N/Profile).** The two columns display the selected multi sensing profiles, for ZX832 Paradigm multi sensors, for both day and night settings.
13. **Sounder Group (Sndr Grp).** The column indicates the sounder group the device will operate on alarm. Used for sounder groupings in radio systems.
14. **Smoke Delay (Smoke Dly).** The column confirms if the smoke delay function is applied to the device address. Used for operational alarm delay in systems featuring EN54 control panels.
15. **Time.** The panel time stamp, when the information was received.

Up to 64 panel spreadsheets can be scrolled by the navigation buttons positioned at the top right of the screen display. The selected panel number and name is displayed in the windows adjacent to the navigation buttons.

# Maestro Graphics System

## Maestro Communications Interface

### 3.8.1. Fetch new device data box

The device configuration screens are not automatically updated by the panel. Information is 'fetched' by clicking onto the Fetch button located at the top right of the screen display.

By operating the button the Fetch New Device Data box is displayed.

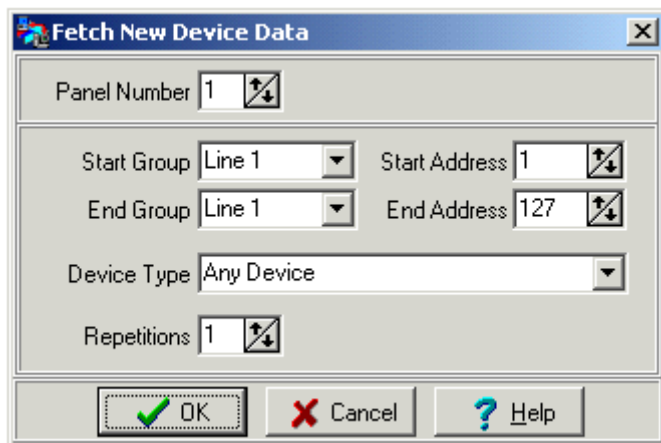

The box provides the following functions.

1. **Panel Number.** By clicking onto the panel numbers any control panel between 1 and 64 can be selected. Upon selection the panel number and name appear in the windows at the top left of the screen display.
2. **Start Group and End Group Windows.** Selects which loops the new information will start from and end at.
3. **Start Address and End Address.** Selects which addresses the new information will start from and end at.
4. **Device Type.** Selects new information from all devices, or filters information by a particular device type only.
5. **Repetitions.** The number of times requested information is to be sent by the panel. Selecting a number of 255 indicates to repeat indefinitely until a stop command is issued.

A timing bar along the top of the main screen indicates the progress during new information 'fetches'.

The three buttons positioned across the bottom of the window provide the following functions.

1. **OK.** Issues the command to fetch the requested information and closes the window.
2. **Cancel.** Cancels the command and clears the window.
3. **Help.** A left hand click onto the Help button displays a menu providing general help information.

During any new information fetch, the operation can be either stopped, or the screen cleared, by clicking onto the Stop or Clear buttons located next to the Fetch button at the top right of the main screen display.

Any of the other Communication Interface display screens may be accessed by clicking onto the appropriate screen tab at the bottom of the display.

# Maestro Graphics System

## Maestro Communications Interface

### 3.9. Initial functional test

It is important to ensure that the fire alarm panel, or panels and the MAESTRO workstation are communicating with each other in both directions, prior to attempting configure the MAESTRO databases.

The main MAESTRO programme should not initially be run simultaneously with the communications interface.

Once the communications between the fire alarm panel and MAESTRO Comms is operating successfully, MAESTRO can be started and configuration commenced. Alarm displays from the main MAESTRO programme always take priority over the display of communication screens, therefore any problems reported to the workstation during initial set up will result in the comms diagnostic screens being replaced with the main MAESTRO system alarm displays.

The two way communication test requires the connection of the workstation to the fire alarm panel, (as shown in Section 6.1) and testing communications, firstly between the fire alarm panel and workstation by pressing the Reset button on the panel. The reset event will be displayed on the diagnostic messages list on the screen display.

The test is then repeated by clicking onto the Reset button on the MAESTRO Comms toolbar. All panels in the system should then be reset and should report back to MAESTRO on the diagnostic messages screen.

Following the Reset messages, the confirmation All Clear will also be displayed in the list signifying the panel is communicating correctly with the MAESTRO workstation.

Communications in the opposite direction (between workstation and panel) are functionally tested, simply by clicking onto the same sequence of commands from the row of buttons located at the top left of the MAESTRO COMMS screen.

### 3.10. Communications interface set up sequence

Communications between the fire alarm panel(s) and the MAESTRO workstation can be set up by a variety of sequences. However the following sequence ensures that elements are inputted in an order that makes full use of all the MAESTRO communications interface facilities.

In order to successfully complete the communications configuration, the following stages must have been already completed -

1. All database input completed. (Section 5.0.)
2. The fire alarm system must be fully installed, with network wiring complete and operational.
3. The main MAESTRO programme should be shut down.

**Stage 1.** Boot up. After displaying the DB verification log, the display defaults to the main configuration screens.

Select Set up communications from the Comms menu (Section 3.4.2.). Input comms information. (Section 3.4.2.1.)

**Stage 2.** Set up panels at the workstation. The controls for each fire alarm panel are set up from the Set up panels menu. (Section 3.4.4.)



# Maestro Graphics System

## Maestro Communications Interface

**Stage 3.** Configure panels to recognise workstation. Each panel on the network must be configured to recognise the MAESTRO workstation (usually as address 64).

Information on configuration at the control panel is given in the following ZP3 Fire Alarm Panel Manuals.

Publication UD 1062A Iss 04, Page 2-20.

Publication UD 1106 Iss 01e, Page 2-14.

**Stage 4.** Functional test. Run functional tests, in both directions, by initiating various alarm conditions at each fire alarm panel and various control functions to each panel from the MAESTRO workstation, via the comms interface screens.

**Stage 5.** Boot up main MAESTRO programme. Check that all main programme functions and displays are operating correctly. Operate a range of alarm conditions from each panel, checking that the appropriate information is displayed at the MAESTRO workstation.

### 3.11. Maestro Comms Planner Jobs

Maestro Ver 3.01 provides support for uploading and downloading Planner configuration, messages and maintenance data when either P2P-3 or ZCP2V3 protocols are selected. This facility permits panel configuration upgrades to be done remotely from the Maestro terminal. The data transferred is sent or received via a compiled panel file exported or imported into Planner.

Navigate to Maestro Comms\Planner jobs.

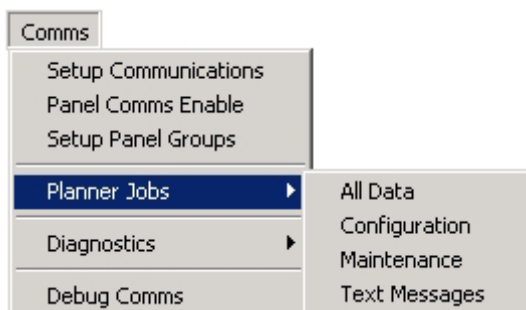

The panel data file information will be saved to a file on the computer. The user will be prompted for a panel file name and path to which the Planner file will be saved.

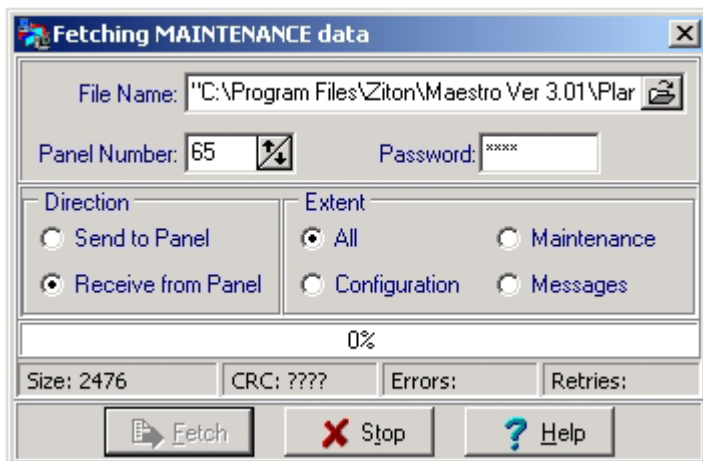



# Maestro Graphics System Commissioning Manual

## Section 4 Map Preparation

UD1277.4  
Issue 3  
10/01/2005



# Maestro Graphics System

## Map Preparation

### 4.1. Introduction

An important aspect of configuring MAESTRO is the preparation, appearance and style of the range of site maps, displaying the areas covered by the fire detection and alarm system.

Screen displays are the main visual element of the system. Appearance and clarity play an important role in product acceptance and use, regardless of the system features.

With care and planning MAESTRO maps may be produced to provide an aesthetically pleasing finished product, offering a practical and easily understood representation of the system and site layout.

### 4.2. Map structure

MAESTRO maps comprise three distinct elements -

1. A series of static maps (or plans) depicting the protected site.

Static map images are prepared from site information held either on electronic disc, or developed from as installed drawings, via a PC software drawing program.

2. Dynamic markers (or icons) represent the position and status of firstly, the fire alarm system zones and secondly individual points (or devices) connected to the system wiring.

A standard range of icon designs is held in the MAESTRO database representing every ZP component. Icons are also provided to signify each fire alarm zone. Additional user designed icons may also be used.

3. Navigation or linking controls, enabling the MAESTRO operator to move from map to map around the map system.

Map page and map navigation buttons may be placed on maps to provide direct methods of moving and switching between the various system maps.

### 4.3. Building zones

To meet the recommendations of British Standard BS 5839 Pt1:1988 Fire Detection and Alarm Systems for Buildings, the site or building covered by the fire alarm system should, for the purposes of ease of communication and identification, be divided into zones.

The process of zoning buildings and the defining parameters of the zones themselves is clearly detailed in Section 7. of the above Code of Practice. It is therefore important that the zones portrayed on MAESTRO maps, must represent accurately the outlines of the zone boundaries shown on the fire alarm system design drawings.

# Maestro Graphics System

## Map Preparation

### 4.4. Map levels

MAESTRO supports a hierarchical structure of map levels permitting a logical flow of information from an overview, at map level one, down through increasing levels of detail.

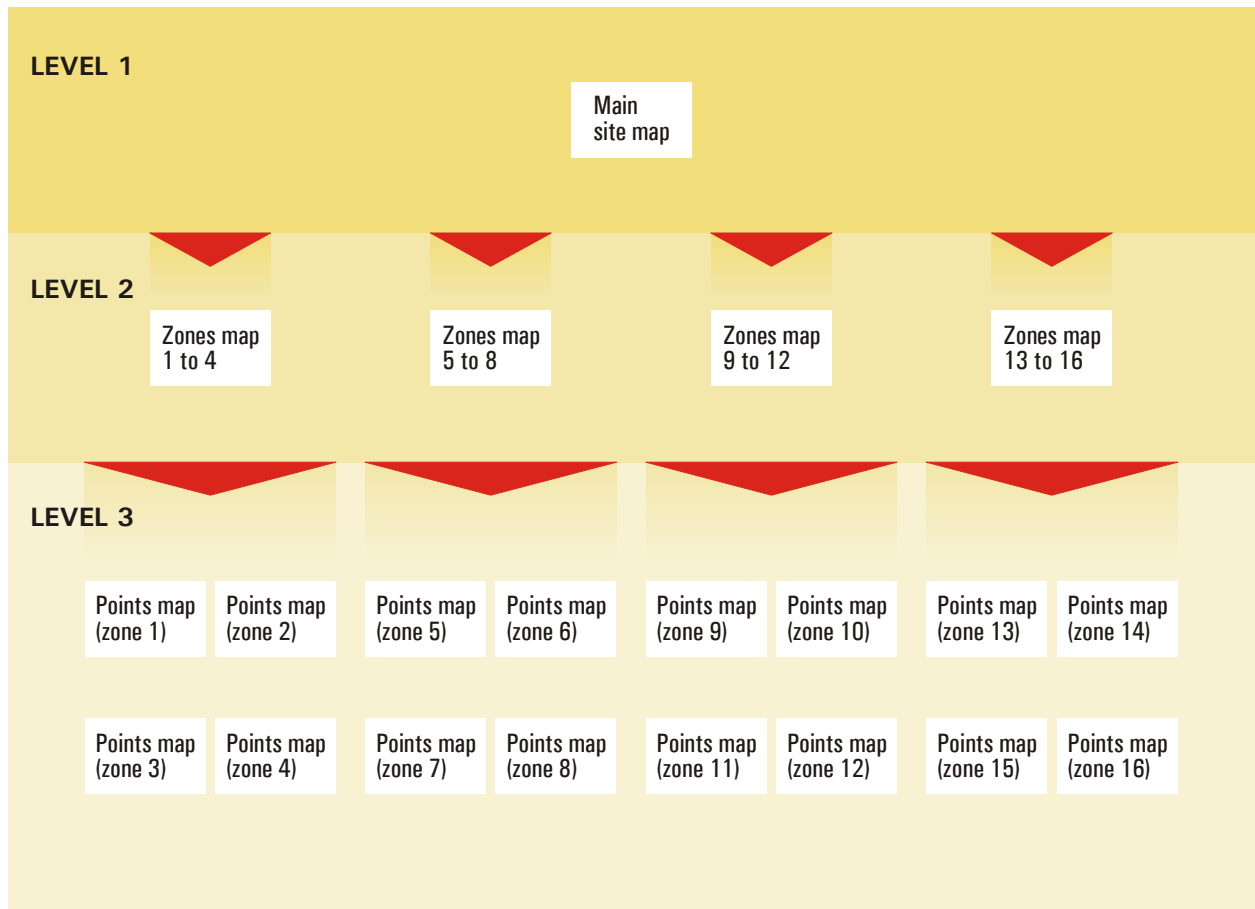

#### Level one maps

The level one map may depict the whole site or building covered by the fire alarm system. It often takes the form of a schematic plan view, showing in general terms the positions and outlines of the major site structures, or building areas. Other image formats may also be successfully employed, including digital photographic images.

In most MAESTRO systems this display is visible on the workstation screen when no alarms are current and the system is in the quiescent state. Site titles or company names and/or logos are often included to convey ownership of the system. It is imperative that map detail is minimal and site detail simplified.

The level one map is often referred to as the Home Page, from which workstation operators may navigate through the map structure.

# Maestro Graphics System

## Map Preparation

### Level two maps

The level one map is usually sub divided into a convenient number of level two maps. In most MAESTRO systems each level two map will show a specific site structure, for example a building sub divided into its individual zones, or perhaps the floor of a large high rise building, again displaying the zonal boundaries.

Sites and buildings can usually be divided up into level two groups by common sense, but care must be taken to ensure that the logical descent from level one down to level two fits exactly the fire plan requirements of the protected site.

It is on level two maps that the zone icons are usually displayed. In any alarm condition, most MAESTRO systems are programmed to automatically display the map containing the zone in alarm (level two).

In addition to the zone icons the level two map will display a selection of navigation buttons linked to the more detailed maps at the lower level three, the home page above at level one and the other zone maps across the second level.

It is therefore important that the maps at level two show clearly the sub division of the zones and their zone numbers. The size and scale of map images should be large enough to represent zones clearly whilst allowing sufficient space for the zone icons and navigation or map buttons, associated with the zones, to be easily identified by the Maestro operator.

### Level three maps

Level three maps usually contain the most detailed map images, but cover relatively small areas of the protected site or building.

Maps at level three usually display the point or device icons. Zones already shown as part of a building at level two, may also be featured on a separate level three map, or on the same map as the devices.

In addition to the point or device icons the level three map will display a selection of navigation buttons linked to the zone maps at the higher level two, the home page above at level one and the other point maps across the lower third level.

In cases where the zone area is extensive, it will usually be necessary to provide several level three points maps in order to cover each zone shown at level two. Likewise in buildings with many compartments and smaller zone sizes it is often possible to include several level two zone areas on a single level three points map.

**Note -** *Most MAESTRO systems feature all three map levels in order to separate zonal and device information. It is common however, in areas where buildings or the zones themselves are small, to combine levels two and three and show both zone and point icons on a single level two map.*

*In addition, the three layers of maps is not rigidly enforced by Maestro, in fact many more than three layers are possible if there be a compelling reason to use them. Navigation however is more logically handled through the three layer approach.*

### Icons and navigation controls on maps

Icons and navigation control devices can be positioned to appear on maps at any map level. They are created, assigned and positioned onto the static maps within the MAESTRO database (described in detail in Sections 5.3 and 5.5).

# Maestro Graphics System

## Map Preparation

### 4.5. Developing the map structure

An important factor in developing any MAESTRO system is to ensure that the salient information only is displayed on each map and that the structure of the map hierarchy allows easy and logical movement around maps at all levels.

There are several good methods of developing the map structure, each of which features a map schedule listing all the maps in the proposed system, with their groupings and links to each other clearly defined. A good map schedule also proves useful in designing the overall map coverage at each level, without lengthy time periods being wasted in unsuitable map preparation.

As a guideline a few of the most important stages in developing map structures are listed below.

1. Study the "as installed" site plan
2. Check the total number of zones in the complete system
3. Assess site layout, and how zones can be logically grouped - perhaps by building, floor or area.
4. Discuss with the user the map level requirements - i.e. will zone icons be shown at level two, with devices at three, or will the map structure have zones and devices shown all on level two and no level three maps.
5. Decide the number of level two maps required to clearly show the zone layout of the part of the site covered by each map
6. Check that the whole site is covered by the set of level two maps.
7. Decide on the number of map navigation control buttons to be shown on each level two map, for moving.
  - i. Back to level one Home Page.
  - ii. Down to the level three detail maps.
  - iii. Across to other level two maps.
8. Check each level two map layout to ensure that zone icons and navigation controls can be comfortably positioned within or alongside each zone area.
9. Provision must be made if titles and text are to be included on level two maps. Text should be kept to a minimum as descriptions of zones, devices in an alarm condition and locations are automatically displayed elsewhere on the screen, or shown on map page buttons.
10. Prepare a map schedule listing the titles (and if necessary a description) of all the level two maps.
11. With the schedule of level two maps complete, produce a list of level three maps associated with each level two 'parent' map.
12. Check each zone shown at level three fits the screen aspect and allows room to display all the device icons.



# Maestro Graphics System

## Map Preparation

13. Decide the number of map navigation control buttons to be shown on each level three map, for moving -
  - i. Back to level two or perhaps, in addition, directly to the level one Home Page.
  - ii. Across to other level three zone detail maps.
14. Decide if large zones, or zones containing large numbers of device icons would be clearer if split onto more than one level three map.
15. Decide if more than one small zone, with few device icons could be combined onto a single level three map.
16. Study the completed map schedule and discuss with system user, to confirm exactly where navigation between maps is required (requirements can sometimes involve the need for direct access from one map to another some distance across the map structure).
17. Since level three maps will cover relatively small areas of the site, try to ensure that enough information to visually identify the location is included on each map. Features such as stairwells, access doors, lifts and passage areas should be shown where possible to enable rapid recognition of an alarm condition.

### 4.6. Drawing Maps

Producing maps which portray the site buildings and important details without ambiguity is an important goal in achieving a functional system.

Most 'as installed' system drawings, whether available as hard copy paper plans, or in electronic format show more detail of the building and its services, than is appropriate to the fire alarm system.

The objective of MAESTRO maps is to provide an indication of the location of an alarm. Architectural and building services detail is usually completely irrelevant, unless it is required to clearly identify a specific area.

This suggests that the lower down the map structure a map appears, the greater the requirement for identifying detail becomes, but the key objective remains clarity and recognition.

Level one maps rarely carry device detail. In most map structures level one may display no icons at all and therefore has the sole purpose of displaying a general layout only. In some systems the level one map may carry the zone icons making the location and representation of the zones an important feature.

A good level one map will usually be based on simple outlines showing the building in a non detailed stylistic form, based on geometric shapes representing the proportions of the protected areas. Where space allows, any major architectural features may be added. At this level, major access routes, external doors and roadways should be shown to permit rapid orientation, especially for emergency services who may not be familiar with the building or site layout.

# Maestro Graphics System

## Map Preparation

A typical style for a level one map drawing is shown below.

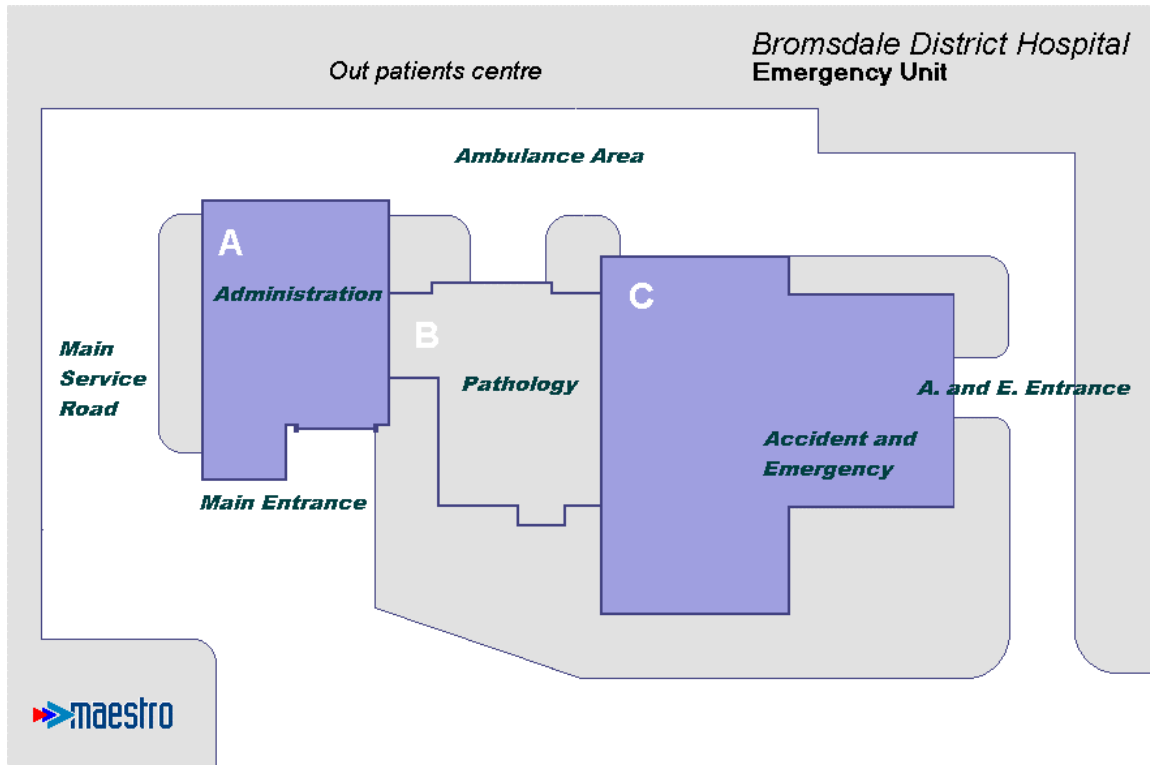

A similar restriction of detail applies to level two maps. Here more detail may be needed to describe graphically the zone areas. A large number of level two and level three maps often associated with a large site will mean that maps have to be produced directly from client drawing files. Even so it is important and usually worth the time to ensure that all unnecessary drawing layers are removed, leaving only the building and zone outlines.

A typical style for a level two map drawing is shown below.

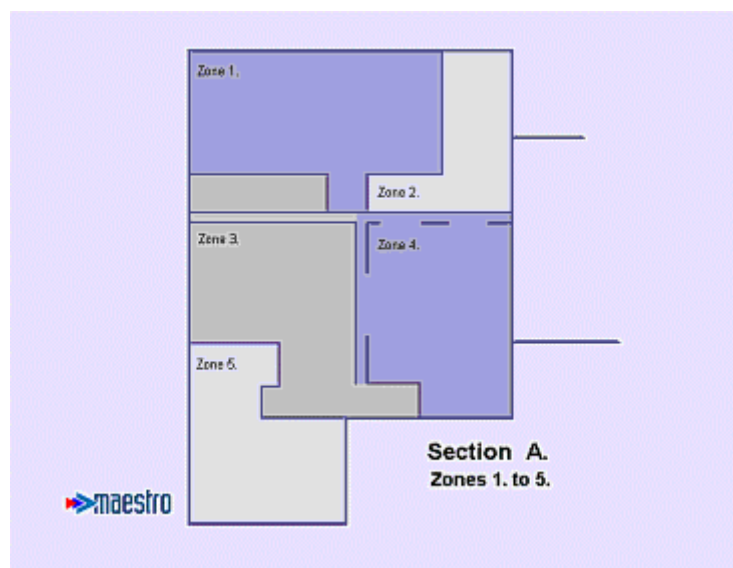

# Maestro Graphics System

## Map Preparation

At level three, where the location of the fire alarm system components will be shown, the inclusion of more building detail may become necessary. Even so, architectural detail should be restricted to the minimum. The use of bold unambiguous labels is recommended, allowing quick recognition of the device location by the MAESTRO workstation operator.

A typical style for a level three map drawing is shown below.

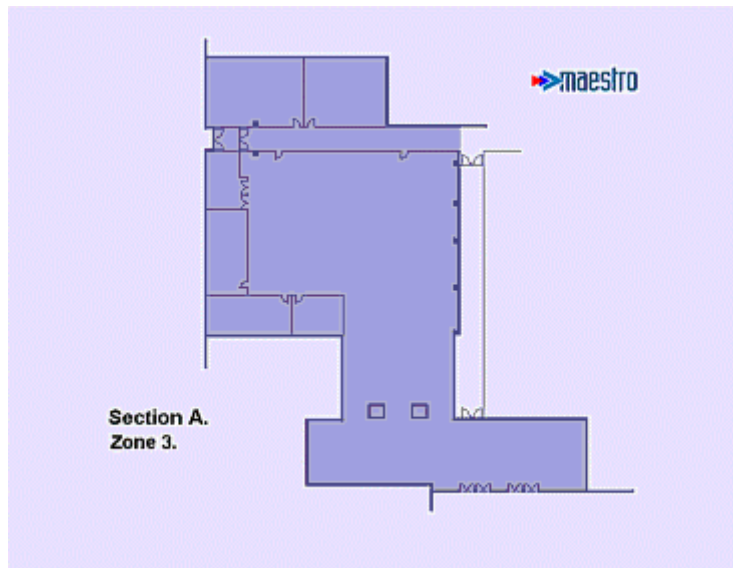

### 4.7. Producing drawing files

#### Drawing file types

Maestro supports two common drawing file types: \*.bmp for bitmapped drawings and \*.wmf for windows metafile drawings. Bitmapped drawings are suited to photographic images, whilst metafiles are better for line drawings and give better results when zooming into a map. Many drawing packages, for example, Coreldraw and Autocad support these drawing formats and provide a mechanism to take in Architectural Drawings and allow the superfluous detail to be eliminated. In addition the drawing plans may be broken down into smaller units for the various level two and level three maps.

A default Front Screen map is a bit map file named "Front Screen. Bmp" and is held in the MAESTRO/MAPS folder.

The Front Screen may be retained, or replaced with the level one site map by replacing the default file using NT Explorer directly into the folder.

#### Screen resolution

The drawing package screen must be matched to the resident MAESTRO system display (e.g. 1024 x 768). The map window size is 874 x 527 pixels at 72 dpi. This compares approximately to A5 landscape format.

This aspect ratio must be maintained when importing maps into MAESTRO. These settings are for the CorelDraw drawing package and should ensure that the finished map size will fit the allocated

# Maestro Graphics System

## Map Preparation

MAESTRO screen area. Metafiles will be automatically scaled by Maestro to fill the available area, whilst retaining the original aspect ratio.

A trial map should be produced in order to confirm map to window size. It is important, with regard to the overall aesthetics of the map structure, that all maps fit the window size.

Maps that are too small are displayed with unsightly borders to one side of the screen area. Maps that are too large cannot be displayed in their entirety and although scroll bars are provided to view maps too large for the map window, this can prove tedious for the MAESTRO workstation operator, especially during an emergency situation.

Where scale or map detail prohibits the map size fitting the screen area, the map file should be subdivided and redrawn as more than one map image.

### Using colour on maps

Maps can be enhanced and detail made more distinctive by adding colour to map images. However the following considerations are listed below as guidelines.

1. Use neutral, non imposing colours. The use of vivid blocks of primary colour can result in maps that are both difficult to distinguish detail on and uncomfortable to view on the screen, over long periods.
2. Limit colours used. If for example a level two map shows six zone areas, consider using just two or three complimentary shades alternately, rather than six different colours.
3. Consider using shades of the same colour. Map areas, especially zones can be effectively differentiated by using a variety of shades of the same base colour.
4. Theme colours. A display of maps can look more effective when the same colours are used throughout the map series. This can confirm that the maps all belong to the same family, promoting familiarity when the MAESTRO operator moves quickly up, down or across map levels.
5. Icon colours. Where icons and navigation buttons appear on colour backgrounds, check that their appearance and colour (green in their normal state) is complimented by the background and that they remain distinctive regardless of their alarm state colours.
6. Map background colours. Coloured backgrounds can enhance the overall map image and be less tiring to view over long periods of time. Care must be taken to ensure that background colours are of neutral, non imposing colours. Pale pastel shades usually work well at contrasting map details.
7. Black and white printouts. Before completing a series of maps, check that both outlines and areas of colour are clearly reproduced in monochrome. Even with advanced colour printing, most hard copies of maps will be produced in black and white, especially in emergency situations.
8. Ensure that the video driver card can support a least 64 000 colours or better and avoid using any "dithered" shades which will render text and fine detail illegible.

# Maestro Graphics System Commissioning Manual

## Section 5 Maestro Database

UD1277.5  
Issue 3  
10/01/2005



# Maestro Graphics System

## Maestro Database

### 5.1. Introduction

The MAESTRO database holds information on every zone and device within the fire detection and alarm system. Signals from devices are received by the MAESTRO system via the fire detection control panel, (or panels) forming the fire alarm system or network.

Information is inputted into the database via a series of six database screens. Initial information is usually imported directly from the fire alarm PLANNER files, prepared at the commissioning and configuration stage of the fire detection and alarm system installation.

PLANNER files may be imported into the workstation, from 3.5 ins floppy discs, or from files located on the workstation PC from previous fire alarm system commissioning.

MAESTRO accepts the listings of zones and devices from PLANNER and assigns a tag number to each. Information on device type, panel, number, loop number and zone number are automatically registered from PLANNER. In addition, the device message and zone name are retrieved by PLANNER. Location details and the map the device icon is to appear on are manually attributed via the tag database editing functions.

Maps are imported from previously prepared image files via the map database. This also provides functions for generating and positioning device and zone icons onto map backgrounds.

Details of the control panel, (or panels) connected to the system are held in the panel database, which offers selections of which system functions and events (for each panel) are to be controlled, displayed or operated by MAESTRO.

Either standard or custom icons can be selected or produced in the icon database. The icon designs for each different alarm state and control function of the system fire alarm components, are configured within the icon database.

The user database allows security passwords to be assigned to several MAESTRO operators. Allowable operator functions are selected individually for each workstation user, dependent upon status and operating responsibility.

The database also provides functions for selecting printers, importing and selecting distinctive alarm workstation sounds, providing audible warning of incoming alarms. The selection of custom alarm type titles, with text and background colours for workstation banners and alarm headings can also be selected.

#### 5.1.1. Accessing the database screens

The Installation User default password is "install". This provides initial access to all programmes, including the User Database (Section 5.6.) where passwords can be assigned to users and the default cancelled.

The database is accessed via the main MAESTRO operating screen. Right hand clicking onto the User Log on/Log off button displays a drop down list from which the Commissioning Tools item is selected. Alternatively, click on the commissioning Tools button (top, right section of the home screen).



Note, both access to the database and which input screens are displayed depends upon the user access, assigned to the password holder in the User Database.

# Maestro Graphics System

## Maestro Database

The six main database sections are illustrated below.

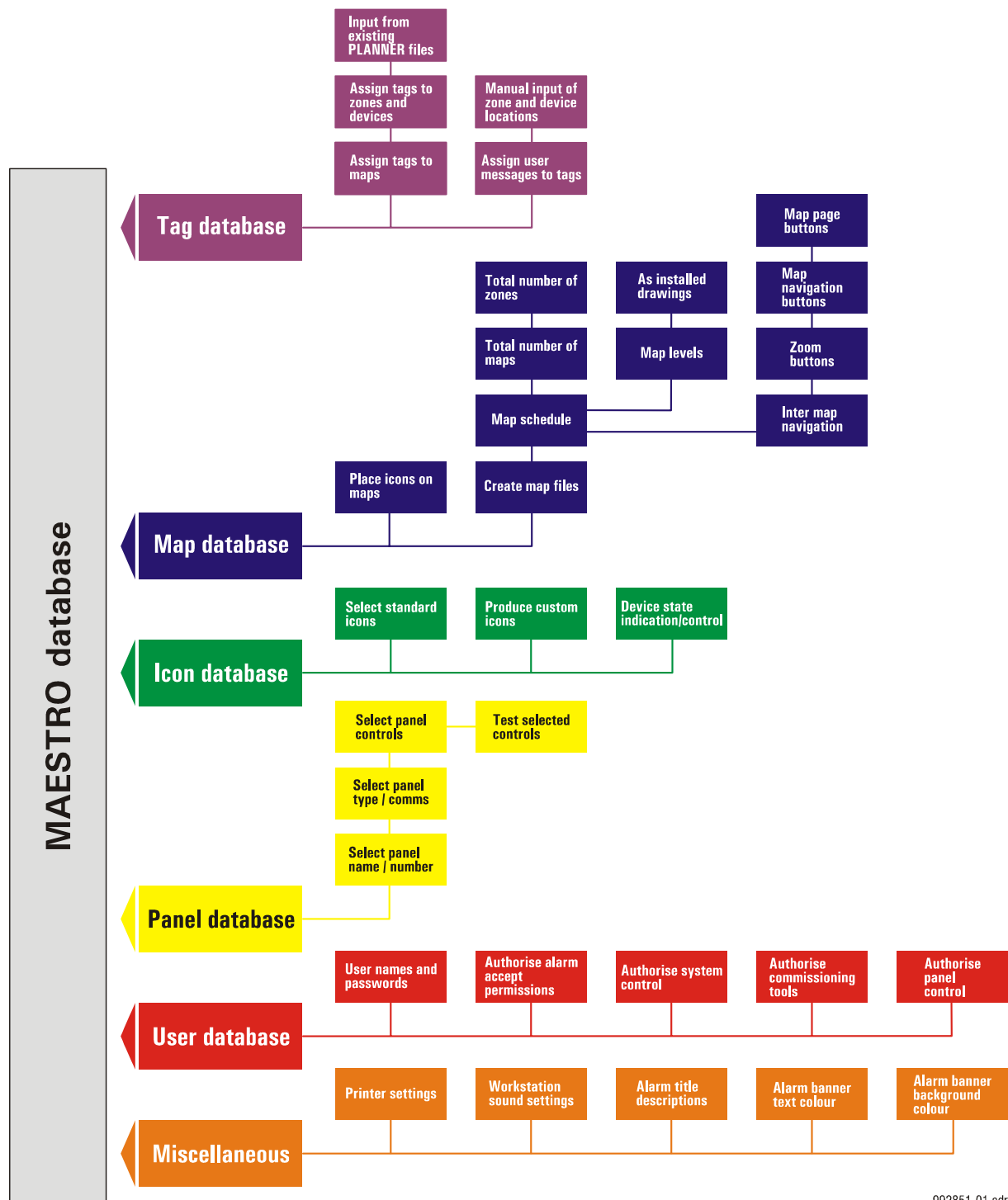

992851-01.cdr



# Maestro Graphics System

## Maestro Database

### 5.2. Tag database

#### 5.2.1. Tagging

Every device, zone, panel or other system component is uniquely identified by three pieces of information, the panel number, the loop or group number and the address. To simplify the recognition of each device to the workstation user a shorthand code called the Device Tag is used by MAESTRO. By convention, the Tag is formed by three numbers, for example:

**7 - 4.109**

The first number identifies the panel to which the zone or device is connected. The above device tag would represent a system component connected to panel number seven in the fire detection system network.

Although MAESTRO operates in networks of up to 64 panels, number 64 is usually reserved for the MAESTRO workstation. This is the default number provided in the MAESTRO programme set up software. The workstation can however be assigned any number.

Panel numbers in a multi panel network are defined in the PLANNER system software prior to being imported into the MAESTRO system. Panels can therefore be assigned any panel number, however in single panel systems the control panel is usually designated panel number one.

The second number in the tag series identifies the loop (or line) to which the device is connected or of which the zone is part. Each panel in the system may have up to four loops (up to eight in systems prior to the current panel range). As with the panel number, the loop number will be defined in the PLANNER system software, prior to being transported into the MAESTRO system.

The final three digits identify the device address number on the loop and may be of any value between 1 and 127.

In addition to the fire detection system components, each zone of the system is provided with a tag number composed similarly to that of the device sequence, except that the loop number is set to 11.

Loop numbers of 9, for system I/O devices, 10 auxiliary I/O devices and 18 for other input devices are also commonly used.

Although MAESTRO will automatically assign a tag number according to the structure above, any short description of up to ten characters or digits can be used as a tag name, provided only that the description is unique and meaningful to the workstation operator.

# Maestro Graphics System

## Maestro Database

### 5.2.2. Tag database input screen

Tag numbers and information are entered into the MAESTRO system by means of the tag database screen. The screen is accessed by clicking onto the Tag database page tab located in the row running across the top of the display.

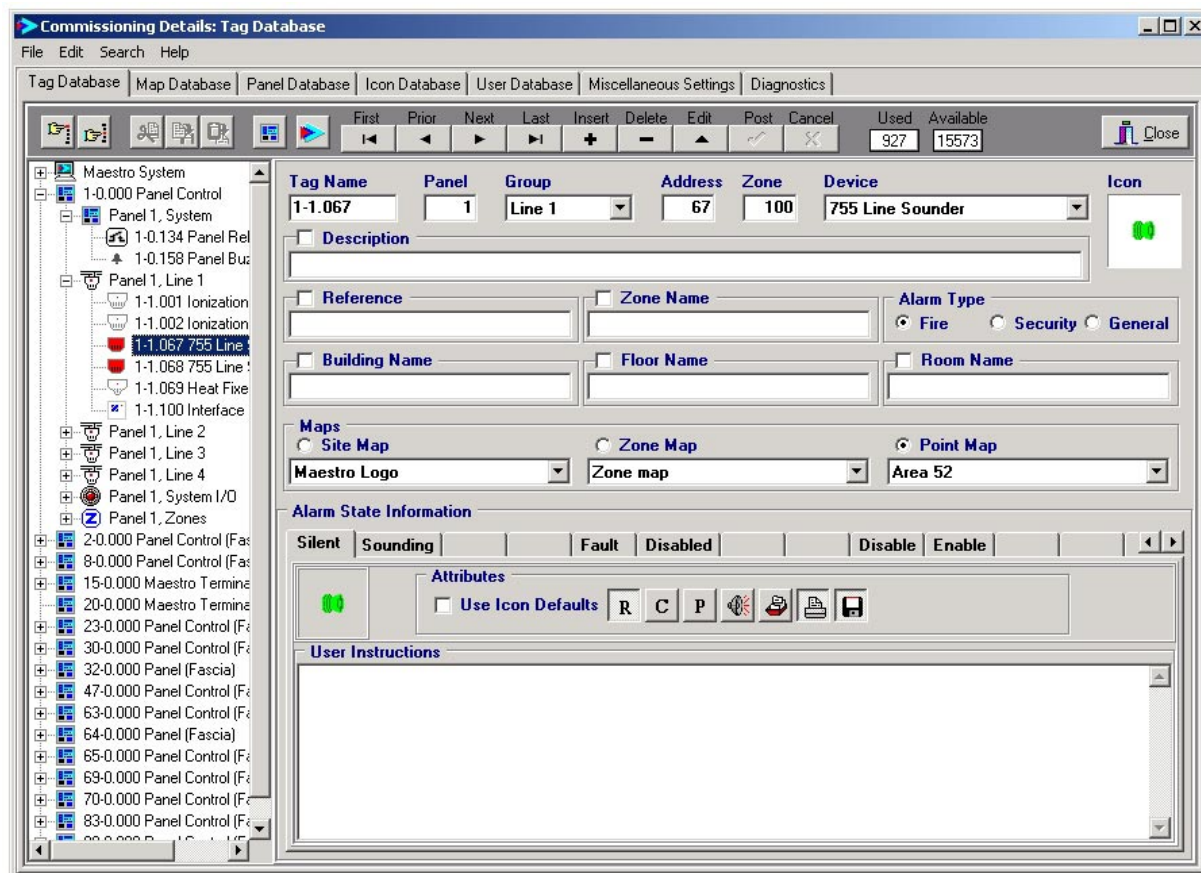

When accessed the database title appears in the bar across the top of the workstation screen.

The tag database display is divided into four sections, tag information input; alarm state information, tag index list and navigation and editing buttons.

#### Tag information input

The upper part of the display screen provides edit fields for the input of the following device or zone information.

1. **Tag name.** This is the identification number of the device or zone and is usually assigned automatically by the MAESTRO system. A user defined tag name may be used if required.
2. **Panel.** The panel number in the fire alarm system, from 1 to a maximum of 64.
3. **Group.** The loop or line or other type of connection of the tagged device to the control panel. A drop down list provides a selection of available group types.

# Maestro Graphics System

## Maestro Database

4. **Address.** This is the device loop address, from 1 to a maximum of 127 for loop devices.
5. **Zone.** This is the zone number to which the device belongs.
6. **Device.** Device type name. Selected from a drop down list of device types.
7. **Icon.** Window shows an illustration of the zone or device icon.
8. **Description.** 80 character description of zone or device. Usually corresponds to the device or zone message in the panel, but not restricted to that.
9. **Reference.** Any user reference grouping. Sets identification in order to retrieve device and zone information in displays, reports and event logs.
10. **Zone name.** Zonal grouping details. Sets identification in order to retrieve zone name in displays, reports and event logs.
11. **Alarm type.** System type, fire alarm, security or general. Places device or zone into system category, where systems other than, or in addition to, fire alarm are being supervised by MAESTRO.
12. **Building name.** Sets identification in order to retrieve building name in displays, reports and event logs. Optional field.
13. **Floor name.** Sets identification in order to retrieve floor name in displays, reports and event logs. Optional field.
14. **Room name.** Sets identification in order to retrieve room name in displays, reports and event logs. Optional field.
15. **Maps.** Windows for selecting map level at which the zone or device will appear site map (level 1), zone map (level 2), points (map level 3). Drop down lists provide selections originated in Map Database.

Next to the Description, Reference, Zone Name, Building Name, Floor Name and Room Name fields, a small check box is provided. By checking the appropriate box, the information contained in the corresponding text box will be included in the Alarm message displayed when any alarm for the device occurs. If the box is unchecked, then the corresponding text field is omitted from the alarm message, but is still recorded in the Event Log.

A number of the above windows will be automatically filled when downloading PLANNER files into the MAESTRO system.

# Maestro Graphics System

## Maestro Database

### Tag Tree

A tree structure is used to indicate Maestro tags.

This allows for ease of navigation within the tag database.

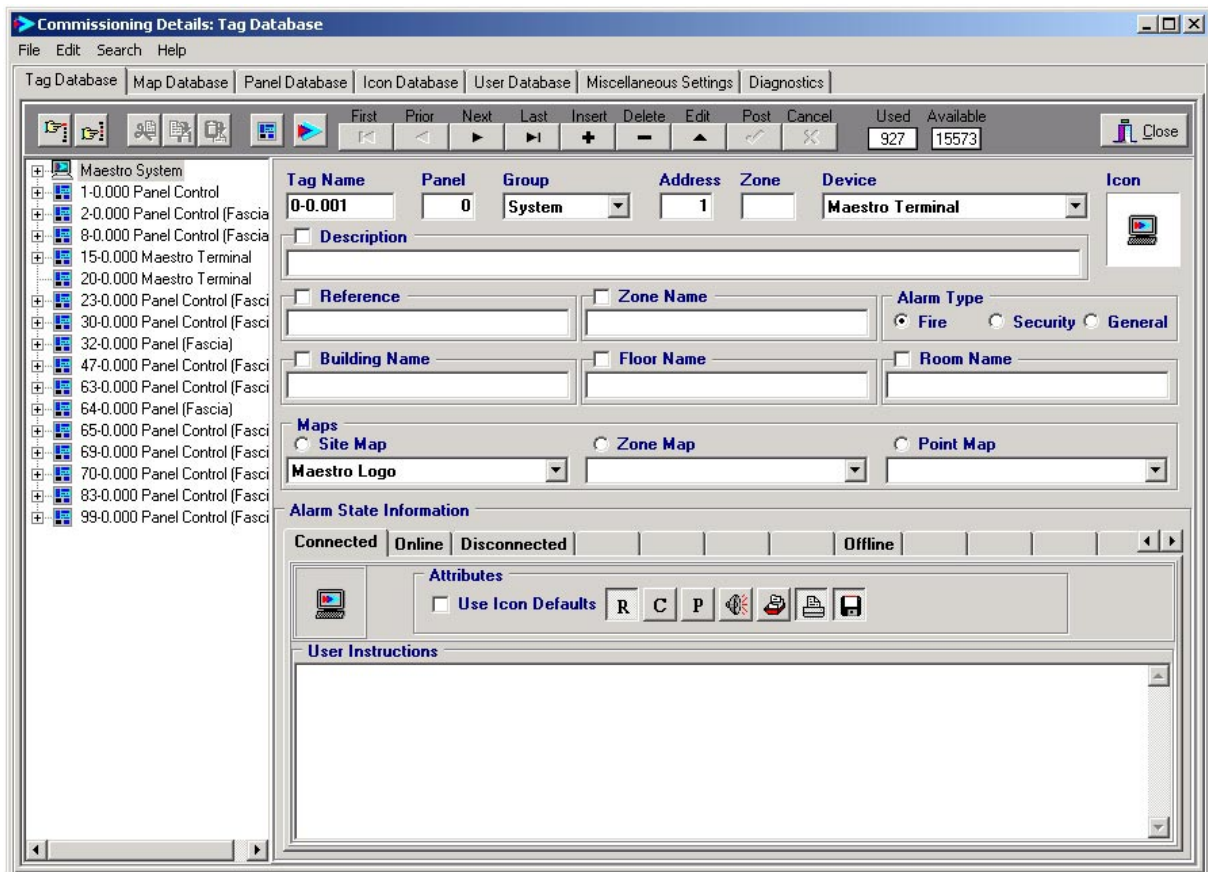

### 5.2.3. Alarm state information

The lower part of the database screen provides input for zone and device alarm state descriptions. When zones or devices change state, for example from normal to pre alarm, or from pre alarm into the full fire state, different messages are displayed via the icon information card, in the main MAESTRO programme. The alarm state input notepad enables a series of user instructions to be created for display by a zone or device icon information card, for each different alarm state.

# Maestro Graphics System

## Maestro Database

The notepad consists of a series of tabbed input cards. One series for each zone or device in the system. Each card in a series provides information for a particular state. The number of input information cards for any zone or particular device type will depend upon the number of alarm states the device can enter. An optical smoke sensor with several alarm states, normal, pre alarm, fire, fault, service, enabled, disabled has more states than for example a manual call point and hence more cards are shown in the optical smoke sensor card series.

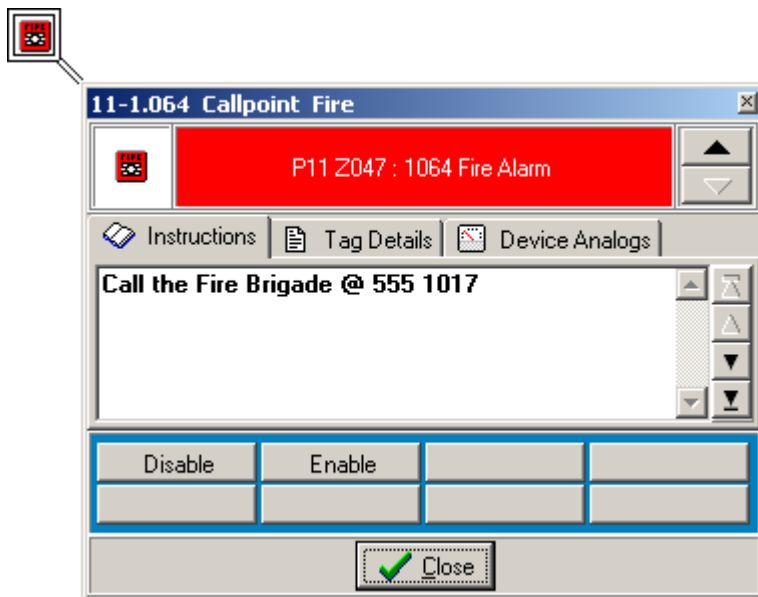
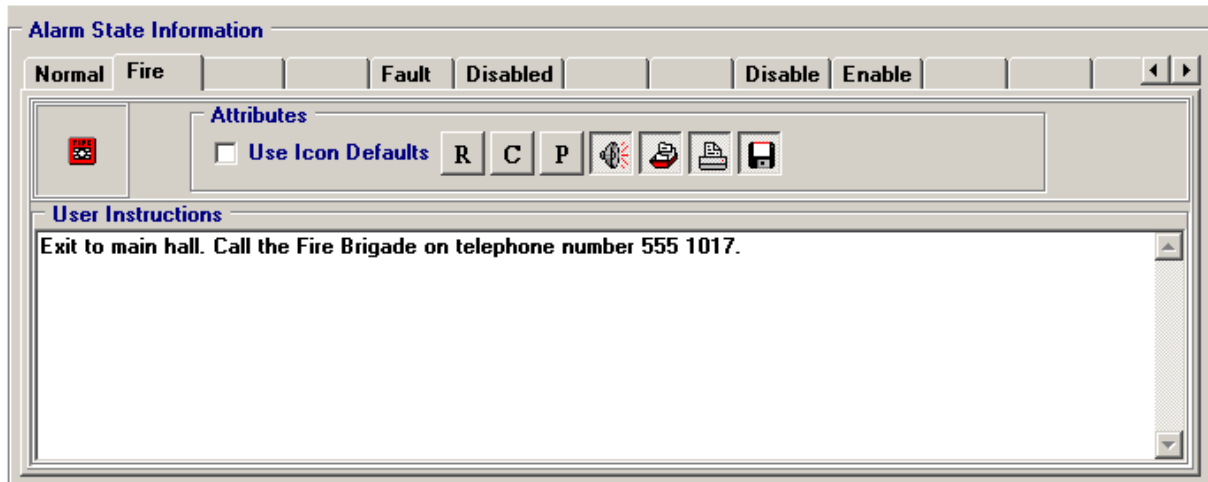

The illustration on the previous page shows the Alarm State Information input card for a manual callpoint in the fire alarm state and the corresponding icon information card, seen by the workstation operator.

Alarm state cards within the device series are accessed by clicking onto the row of card tabs along the top of the Alarm State Information display. Where devices possess many states, the tab list can be scrolled horizontally by means of the scroll arrows located at the right of the tab row.

The relevant zone or device icon, colour coded for the alarm state selected is displayed at the top left of each input card. The alarm state note pad space can be extended by the scroll bar located down the right of the card display. However messages should be kept as brief and to the point as possible to allow the workstation operator to react to the MAESTRO system as quickly as possible.

# Maestro Graphics System

## Maestro Database

To test the appearance of the device icon for each possible alarm state, double click onto the icon to cause it to flash as if it was an alarm. Double click again to stop the flashing.

To assist the User Instructions, Windows Cut/Copy and Paste commands can be used to copy text from one card to another. To copy or cut text to the clipboard, first select the required text (by placing the mouse cursor over the text and dragging it over the required text whilst holding the left mouse button down), then press Ctrl-C (to copy) or Ctrl-X (to cut) the text to the clipboard. To paste from the clipboard position the mouse cursor where the text is required to be placed, then press Ctrl-V key combination to insert the text.

The individual device attributes sub section of each card is under development and is not yet available to the user.

### 5.2.4. Tag index list

The tag index list is located down the right side of the Tag Database screen display and provides a means of selecting any existing tag database page. The current selection is highlighted in the list. The list can be scrolled vertically by means of the scroll bar down the right of the list and extended horizontally in order to read device types where necessary.

Any tag number page can be accessed by clicking onto the appropriate tag number in the index. On selection the tag is highlighted and an arrow is displayed next to the tag number.

Navigation tools are provided at the top of the index list. Any existing tag page can be located by typing the tag number into the 'find tag' window and clicking onto the arrowed 'find' button to the right. The required tag page is displayed together with the part of the index holding the tag number. Partial searches are possible by entering the first few digits of the required number and then pressing the Find button. The selected tag number is highlighted in the index list.

Buttons are provided below the 'Find Tag' window to enable moving up and down the list and returning to either the first or last entry. A black arrow to the left of the tag number also marks the current list position.

To provide further clarity, when moving around blocks of numbers in some editing procedures, the original tag number remains highlighted with the location arrow to the left of the number changes to a black dot.

When a tag page has been edited and not yet saved to the database, the location arrow changes to an "I" beam marker

### 5.2.5. Navigation and editing toolbar

The Tag database navigation and editing tool bar appears across the top of the screen display and provides the following database functions -

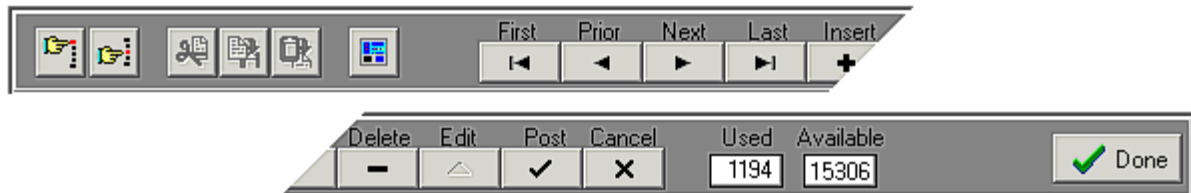

#### Find tag and Next tag buttons

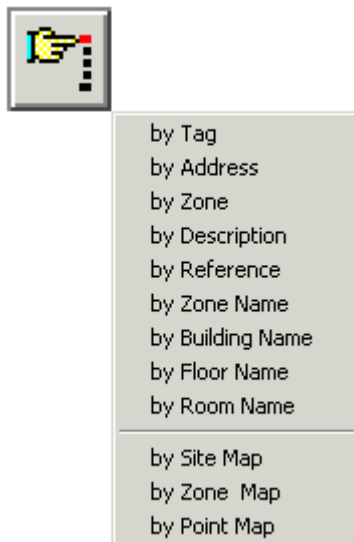

By clicking onto the Find Tag button a drop down list provides several parameters for tag selection. The selected parameter is chosen by clicking onto the appropriate item in the list and completing the requested details in the dialogue box displayed.

The tag page corresponding to the first tag matching the selection criteria will be selected. To find subsequent matches, press the find next tag button.



The Next Tag button moves the database screen to the next tag listed in the index.

#### Cut, paste and copy buttons



The three editing functions are accessed by clicking onto the appropriate button in the toolbar.

Several zone and device information input windows, together with the user instructions notepad information are not automatically downloaded from PLANNER files making the above functions time saving when inputting the same descriptions for many separate but identical devices.

# Maestro Graphics System

## Maestro Database

### Planner programme input button



In most systems all tag information will be downloaded into the Tag Database direct from existing PLANNER files.

Clicking onto the PLANNER import button displays a dialogue box enabling the user to select the PLANNER file to import from.

During the import process if any conflicts are found between the data contained in the PLANNER file and any entries already in the MAESTRO database a warning message is displayed on which the user may select to retain the information in the MAESTRO database, or overwrite it with the PLANNER setting.

### Used and available counters



The used and available counters are shown to the right of the navigation toolbar. A total of up to 16 500 individual tag numbers are available, depending upon the size of the MAESTRO system.

As tags are added to the system, the used total increases as the available total decreases.

## 5.2.6. Tag Creation Wizard

### Features

The Tag Creation Wizard allows the user to easily generate multiple tags.

### Procedure

1. Launch the Tag Creation Wizard by clicking on the button shown below.





# Maestro Graphics System

## Maestro Database

2. The Tag Creation Wizard form (shown below) will be displayed.

The screenshot shows the 'Tag Creation Wizard' dialog box. It includes fields for Panel (1), Group (Line 1), Start Address (1), End Address (8), Zone (1), and Device (Ionization). There is a 'Start' button with a green checkmark. Below these are checkboxes for Description, Reference, Building Name, Room Name, Zone Name, and Floor Name. An Alarm Type section has radio buttons for Fire (selected), Security, and General. A Maps section has radio buttons for Site Map, Zone Map, and Point Map (selected), each with a dropdown menu. The Site Map dropdown shows Maestro Logo, Zone Map shows Railway 15(71), and Point Map shows Railway 1(71). At the bottom are Close and Help buttons.

### 5.2.7. Exit from the database



On the completion of data input or editing, the operator can move to any of the other MAESTRO databases by clicking onto the appropriate database tab from the row displayed at the top of the screen display.

Alternatively the workstation display can be returned to the main MAESTRO program Home Page, by clicking anywhere off the database display part of the screen, or onto the Done button shown at the right end of the navigation toolbar.

If any changes are made to any data in the tag database, the workstation user will be prompted to make a backup copy of the data before closing down the configuration editor. It is recommended that this option is always accepted to keep the database files as up to date as possible.

### 5.3. Map database

The map database holds all map information. It retains the system map images and allows modifications, additions and removals from the map schedule.

This database function provides.

1. The input for all the site and building maps, at all levels. It holds the map directory, allowing the commissioning engineer to install the visual layouts of the site or building protected by the fire detection and alarm system. Provision is also made for the addition and removal of maps, in order to accommodate site extensions and modifications.
2. Selection, application and positioning of icons onto the map backgrounds. All fire alarm devices are displayed, for each map, as a tag number list. Icons are automatically generated (both standard or custom) and can be dragged, by the cursor, to their appropriate positions on each displayed map.
3. Design and application of map system navigation aids. Map level direction buttons, map name buttons and zoom in/out functions are selected, generated and positioned throughout the map system.

# Maestro Graphics System

## Maestro Database

### 5.3.1. Map database input screen

Maps are entered into the MAESTRO system by means of the map database screen. The screen is accessed by clicking onto the Map database page tab located in the row running across the top of the display.

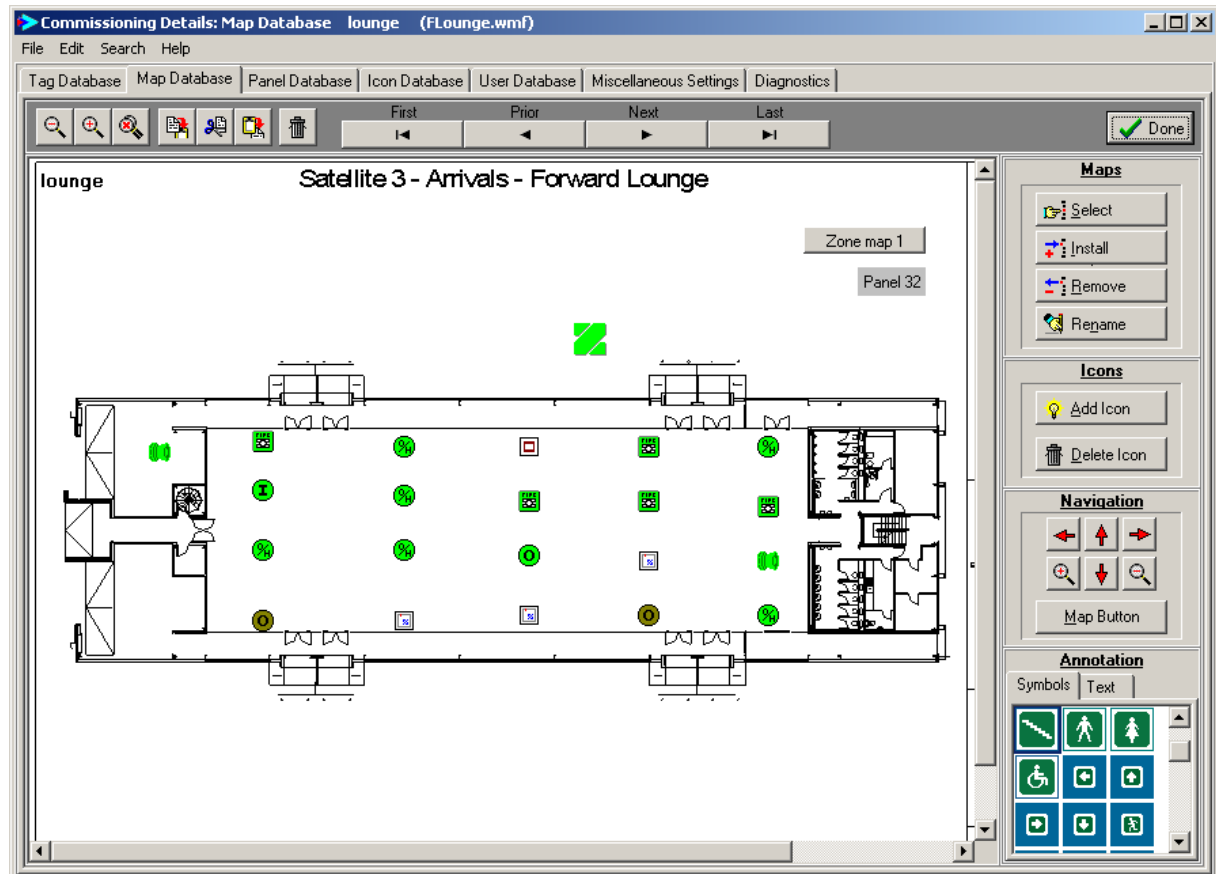

When accessed the database title appears in the bar across the top of the workstation screen.

The map database display is divided into three sections, map editing screen, maps, icon and navigation controls and navigation and editing toolbar.

# Maestro Graphics System

## Maestro Database

### 5.3.2. Map input

Each map from the map schedule is inputted into the map database individually. Maps can be inputted in any order, but it is usually easier (especially in large systems) to follow the order from the previously prepared map schedule, (see Section 4.5. Developing the map structure).

Each map is installed by clicking onto the Install button, located in the block of four Maps buttons at the top of the maps, icons and navigation controls running down the right side of the input screen.

On clicking onto the Install button, the Add a Map box is displayed at the centre of the map editing area. Maps are added by clicking onto the Load button in the Add a Map box.

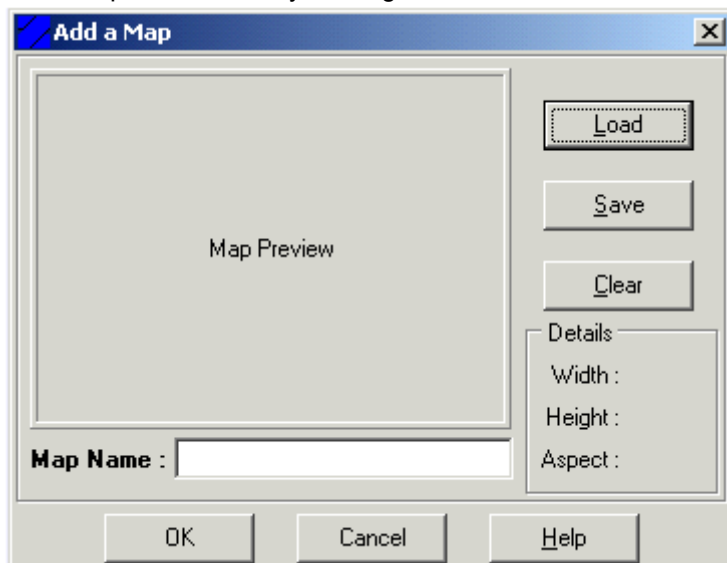

This displays the workstation directory dialog box, from which the appropriate drive and map files can be located. By clicking onto the map title, then the Open button on the workstation directory dialog box, the selected map is shown in the Map Preview of the Add a Map box.

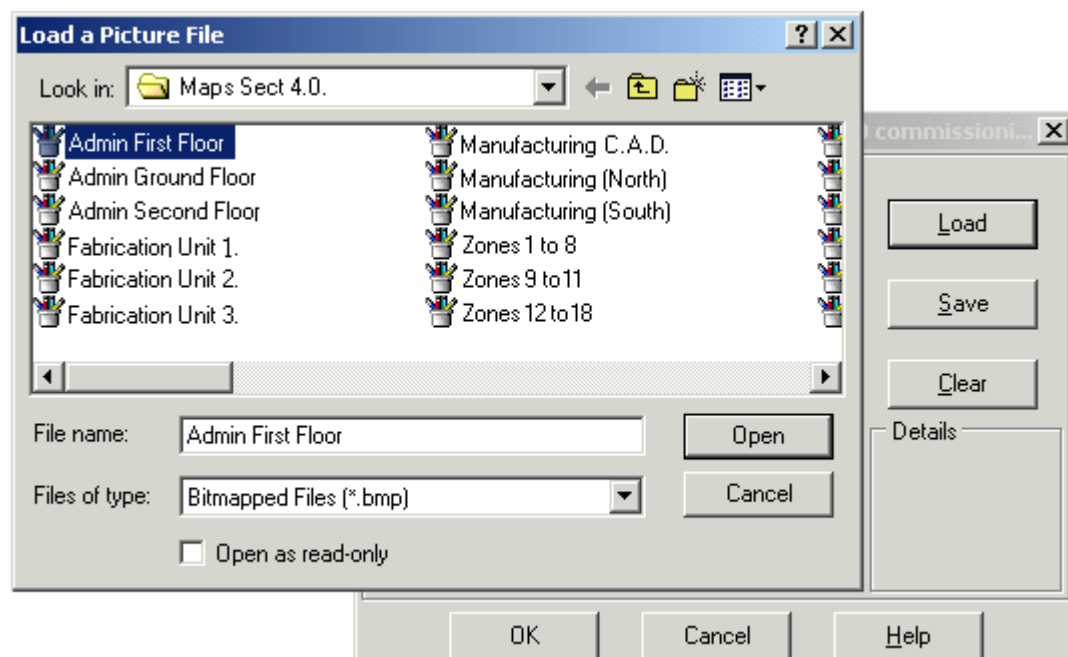

# Maestro Graphics System

## Maestro Database

The following controls are provided on the Add a Map function.

1. **Load.** This button displays the workstation drive directories, for map file selection. Once selected the map file is inputted into the MAESTRO map database by again clicking onto the Load button.
2. **Save.** Opens a map save dialog box to allow the user to rename the selected maps or copy it to a different directory.
3. **Clear.** Clears the image the Map Preview window.
4. **Map details box.** The width, height and aspect ratio for the map displayed in the Map Preview window are listed.
5. **Map Name.** A name for each map must be typed into the Map Name window, located below the Map Preview display. This is the corresponding name input into the Tag database for each device or zone. The name entered here does not have to correspond to the actual file name, but rather reflects the usual name by which the area is known.

**Note:** *Each map must be given a unique name.*

7. **OK.** This button saves the named map into the MAESTRO map database provided the name entered has not been previously used for another.
8. **Cancel.** Cancels the map and name from the Map Preview.
9. **Help.** Displays a menu providing general help information.

### 5.3.3. Maps, icons and navigation buttons

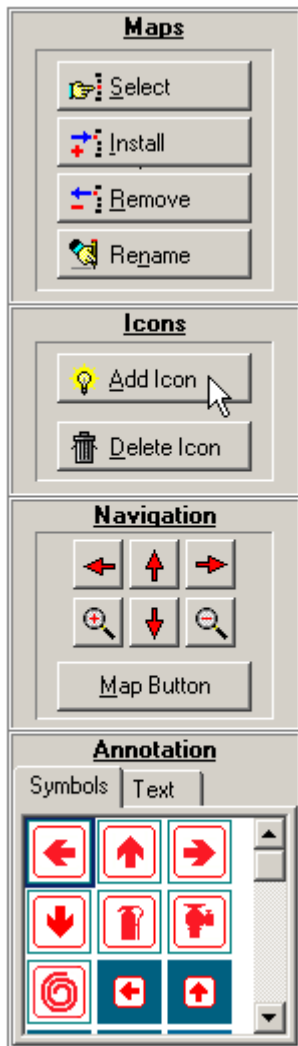

The map database is edited by the buttons in the panel running down the right side of the map database input screen.

#### Feature

Icons can easily be added to the map.

The mouse cursor will change to one of the following depending on the selected map edit option.

Edit option	Cursor
Delete Icon	
Move Icon	

#### Procedure to add an icon to the map

1. The Map Database toolbar will be displayed on the right side of the screen.
2. Left click on Add Icon button. A list of icons will be displayed.
3. Select an icon from the list. Double click on the selected icon to place it on the map.
4. Position the icon by dragging it to the desired position on the map.
5. Click on the Done button (below Apply devices) to revert to the map edit toolbar.

# Maestro Graphics System

## Maestro Database

### 5.3.3.1. Editing maps

Map editing is provided via the four buttons positioned at the top of the Maps, Icons and Navigation controls.

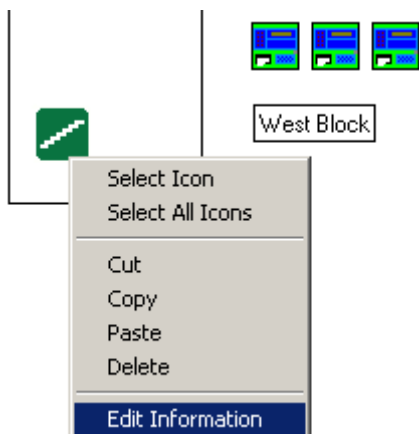

1. **Select.** This selects and displays on the map area any map held in the map database. Clicking on the select button replaces the maps control button area with a window listing all maps held in the database. Individual maps can be selected for editing by clicking onto the map name.
2. **Install.** This opens the Add a map dialogue box and is used to input maps, either during initial system set up or for subsequent map additions or modifications. The install function is explained in detail in Section 5.3.2.
3. **Remove.** This enables the user to remove or delete maps from the database. Clicking on the remove button replaces the maps control button area with a window listing all maps held in the database. Individual maps can be selected for removal by clicking onto the map name.  
  
On selection, a dialog box is displayed for user confirmation, prior to the map being removed from the database.
4. **Rename.** Any map may be renamed, by clicking onto the Rename button. Clicking on the Rename button replaces the maps control button area with a window listing all maps held in the database. Individual maps can be selected for rename by clicking onto the map name.  
  
A Rename window is displayed confirming the current name and providing space for typing in the new map name.
5. **Information card text message editing**

#### Feature

- i. The information card displays information pertaining to the symbol.
- ii. Enhances map information by indicating the location of fire events, fire equipment, etc.

#### Procedure

- i. Right click on the panel map icon and select edit information from the dropdown menu.

# Maestro Graphics System

## Maestro Database

### 5.3.3.1. Editing maps

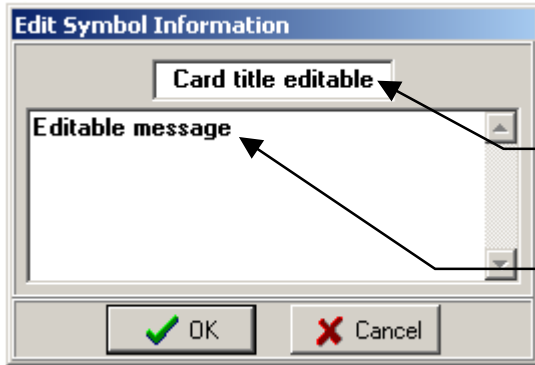

ii. The info card title and info card message may be edited by clicking on the respective text boxes.

EDITABLE CARD TITLE BAR TEXT

EDITABLE INFO CARD MESSAGE

iii. The following is a preview of the information card when displayed in normal operating mode.

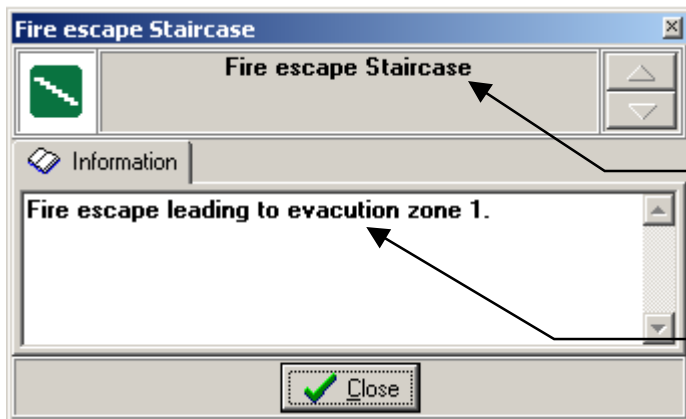

EDITABLE CARD TITLE BAR TEXT

EDITABLE INFO CARD MESSAGE

Preview of the information card when displayed in operator mode

**Note:** That each map must be given a unique name.



# Maestro Graphics System

## Maestro Database

### 6. Text annotations to maps

#### Feature

Allows the user to add text annotations to a map.

#### Procedure

- i. Click on the Text tab (Annotation section of the Map Database toolbar).
- ii. Edit the annotation in the text box eg. zone map 8
- iii. Click on the Add button to place the annotation on the map.
- iv. Drag the annotation to the desired position on the map.



#### Text Annotation labels

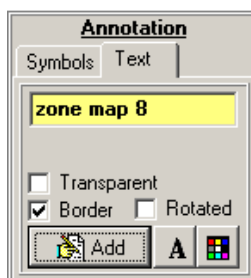

Commission tools show annotation area

# Maestro Graphics System

## Maestro Database

### 5.3.3.1. Editing maps

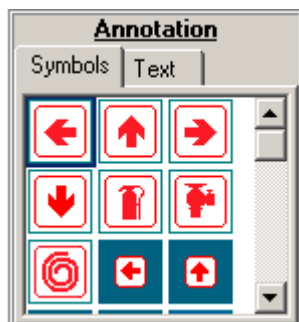

### 7. Adding symbols to maps

#### Procedure

- i. Click on the Symbols tab to view the symbol library (Annotation section of the Map Database toolbar).
- ii. To select an icon left click on the icon in the Symbols library and drag it to the desired position on the map.

# Maestro Graphics System

## Maestro Database

### 5.3.3.2. Applying icons to maps

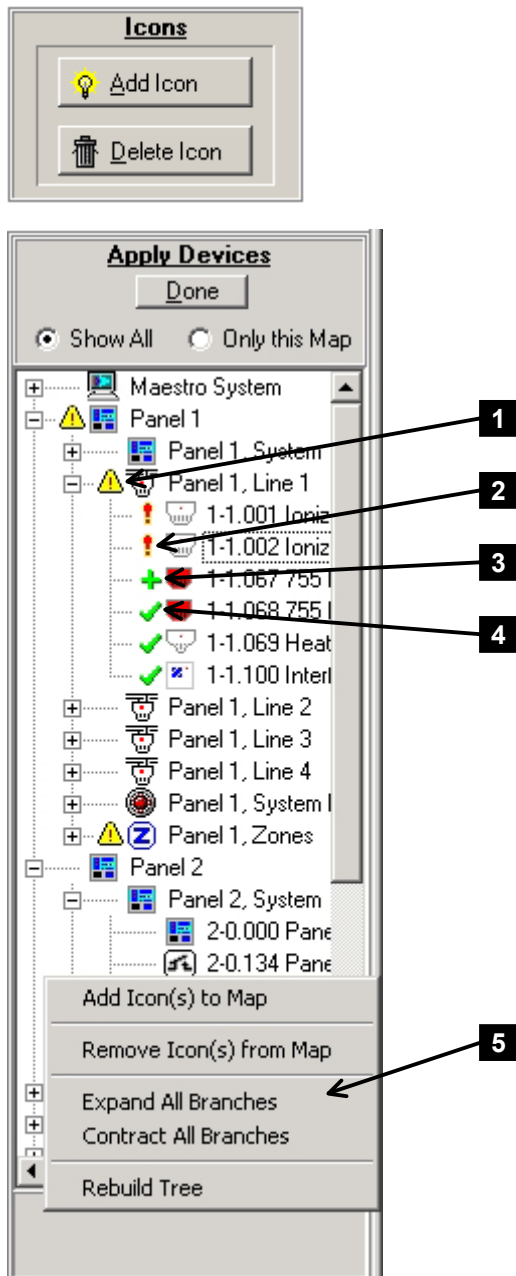

Icons are applied to and positioned on maps by double clicking onto the Add icon button. Clicking onto the button replaces the map, icon and navigation control area with an Apply Devices display featuring a full list of all devices and their tag numbers, from the MAESTRO tag database.

The map where the icons are to be applied is selected (as detailed in Section 5.3.3.1.).

Zones and devices will have been previously assigned tag numbers and map locations, (as part of the Tag database information input). MAESTRO automatically indicates which tags have been selected in the tag database to appear on the selected map and identifies them by displaying them in the overall list highlighted in red.

By double clicking onto the tag name, displayed in red in the list, an icon appears alongside it on the edge of the map. MAESTRO automatically offers the correct icon image, selected from the icon database and corresponding to the device type or zone. This applies to both standard or custom designed icon images.

Once generated onto the edge of the map, the icon can be positioned onto the map by a click and drag action. The appearance of the icon image on the map changes the colour of the tag name and number in the Apply Devices list to a blue colour. The tag remains permanently highlighted in blue, against the displayed map, in order to aid future identification.

Icons shown in black on the Application Devices list are not shown on the current map, and are not identified in the tag database as belonging to the current map. They may, however, be put into the current map if required by the system design.

Once the icon (or icons) have been generated and correctly positioned on the selected map, the display can be returned to the Maps, Icons and Navigation control buttons, by clicking onto the Done button at the top of the Apply Devices display.

#### Map Tree functions

1. (Exclamation mark in triangle) Indicates that there are some inconsistencies between the tag and map database.
2. (Exclamation mark) Indicates that the icon is placed on the map but is not assigned to this map in the tag database.
3. (Plus sign) Indicates that the icon should be added to the map.

# Maestro Graphics System

## Maestro Database

- 4 (Tick) The icon is placed on the map as intended.
- 5 By right clicking in the "Apply Devices" box a function menu is opened. The user can select Rebuild tree (which updates the tree), Contract all branches, Expand all branches, add icons and remove icons.

All additions and modifications are automatically saved in the database memory. Clicking onto the Done button displays a confirmation box, where additions can be confirmed by clicking onto the yes button. The user is prompted to make a backup copy of the screen database. It is suggested to always accept this option.

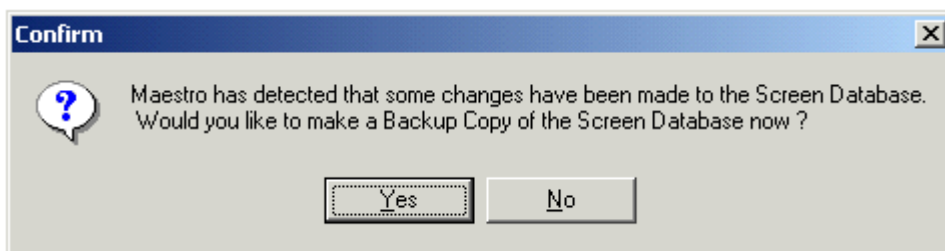

This in turn displays the dialogue box prompting the user to back up all changes to the MAESTRO Screen database.

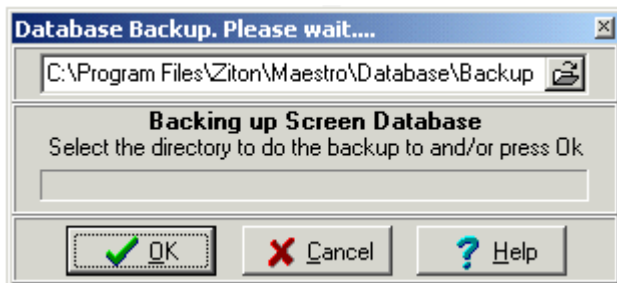

### 5.3.3.3. Removing icons from maps

Icons can be removed from map backgrounds by clicking onto the Remove Icon button. When placed over the icon to be removed, the mouse cursor changes to a cross. A single left hand click deletes the icon.

The corresponding device or zone tag number and name in the Apply Devices list reverts to being highlighted in red. (Indicating that the tag is still held in the tag database but its icon does not appear on the assigned map).

The tag information can only be deleted from the Apply Devices list by deleting the tag reference in the Tag Database main screen. To reinstate icons removed from the maps, click the Cancel button on the Database Backup dialog box.

# Maestro Graphics System

## Maestro Database

### 5.3.3.4. Applying map direction buttons

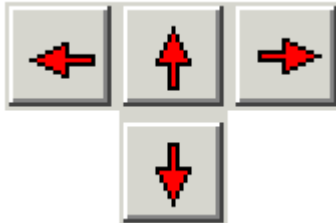

Map direction buttons are square buttons displaying an arrow. They enable the workstation operator to move up or down, or left or right within the map structure, as indicated by the direction of the arrow.

Each map direction button links two maps together enabling the workstation operator to move from the current to the destination map simply by clicking onto the map direction button.

Map direction buttons are generated, positioned and applied onto maps using a similar method to that for icons.

The buttons are generated by clicking onto the required direction button, displayed in the map, icon and navigation control area.

Clicking onto the button replaces the map, icon and navigation control area with a Pan (direction) button display, featuring a full list of all maps, held in the MAESTRO database.

The destination map is selected by a double click on the map title in the list which automatically displays the map direction button in the centre of the screen display. The button can then be moved into any location within the map area by positioning the cursor over the button and dragging it to the required destination.

Once the map direction button (or buttons) have been generated and correctly positioned on the selected map, click onto the Done button at the top of the Pan (direction) display, this returns the user to the maps, icons and navigation controls display.

### 5.3.3.5. Removing map direction buttons

Map direction buttons can be removed from map backgrounds by clicking onto the Remove Icon button. When placed over the map direction button to be removed, the mouse cursor changes to a cross. A single left hand click deletes the icon and returns the user to the maps, icons and navigation controls display.

To reinstate direction buttons removed from the map, click onto the Cancel button on the Database Backup dialog box.

# Maestro Graphics System

## Maestro Database

### 5.3.3.6. Map buttons

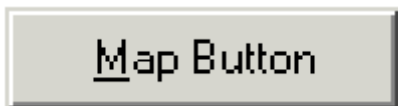

Map buttons are provided to enable the MAESTRO workstation operator to move around the map structure.

Although they perform the same function as the Map Direction Buttons (see Section 5.3.3.4.), they differ in two ways.

1. Map buttons carry the name of the destination map to which they are linked, simplifying identification on maps where several buttons may be featured.
2. They do not carry the arrow direction symbol but provide a direct, descriptive link with the destination maps.

Most large MAESTRO systems will usually feature both Map and Map Direction buttons.

Map buttons are selected, generated, positioned onto and removed from their relevant maps by an identical method to that used for Map Direction buttons. (see sections 5.3.3.4 and 5.3.3.5.)

Names are automatically assigned to the buttons, on the selection of their destination map from the displayed map list.

### 5.3.3.7. Map zoom buttons



Map zoom buttons are provided to enable the MAESTRO workstation operator to select maps that show more or less detail than the current one.

For example a zone map at level two may not be of a suitable size or scale to display large numbers of individual fire alarm device icons. In such cases it may be preferable to include a series of maps at the level below the zone, each providing a full screen display of a small part of the higher level map.

Although the Zoom in and Zoom out buttons operate by linking maps, in the same way as the Map direction and Map buttons, the magnifier design shown on the buttons often conveys a more obvious relationship to the workstation operator, especially in emergency situations.

Most large MAESTRO systems will usually feature all three map navigation devices each used to enable optimum ease of operator movement between specific maps.

# Maestro Graphics System

## Maestro Database

Zoom in and Zoom out buttons are selected, generated, positioned onto and removed from their relevant maps by an identical method to that used for Map Direction buttons. (see sections 5.3.3.4 and 5.3.3.5.)

### 5.3.4. Map navigation and editing toolbar

The map database toolbar runs horizontally across the top of the screen display, and is primarily used for moving quickly through the map directory.



The tool bar provides the following functions, arranged from left to right



Map magnification buttons. Magnifies previewed maps in the database to assist in icon positioning.

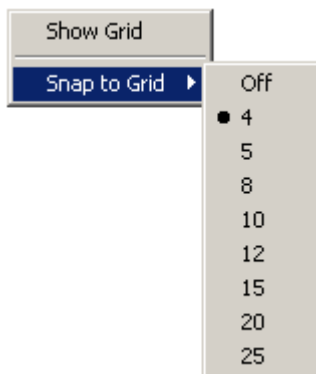

Snap to grid window. Clicking onto the window displays a drop down list of grid scales. The grid (although not displayed across the map image) enables icons and navigation buttons to be accurately placed and lined up.

# Maestro Graphics System

## Maestro Database

### 5.3.5. Commissioning Tools – grid setting

#### Features

Enables the user to increase or decrease the grid spacing to facilitate placement of map icons.

#### Procedure

1. A password is not required to change this setting.
2. To edit the grid setting for a map simply right click on any area of the map, which is not occupied by a panel icon.



First, last, prior and next navigation buttons. Navigates through the full map directory.



Done button. Closes map database and returns the operator to the main MAESTRO workstation programme.



# Maestro Graphics System

## Maestro Database

### **5.3.6. Exit from the database**

On the completion of data input or editing, the operator can move to any of the other MAESTRO databases by clicking onto the appropriate database tab from the row displayed at the top of the screen display.

Alternatively the workstation display can be returned to the main MAESTRO programme Home Page, by clicking anywhere off the database display part of the screen, or onto the Done button shown at the right end of the navigation toolbar.

If any changes have been made to any of the databases in the MAESTRO configuration screens, the user is prompted to make a backup copy of the relevant data changes, when closing down the configuration editor. It is suggested that this option is always accepted to keep the database backup files as up to date as possible.

# Maestro Graphics System

## Maestro Database

### 5.4. Panel database

The panel database holds information to define the panels attached to MAESTRO. This includes the set of allowable control functions for each panel.

Up to 64 panels can be attributed different combinations of controls allowing the MAESTRO system to fit exactly any site requirement.

This database establishes the panel controls and functions. The selected controls and functions, are subject to the permissions granted to the workstation operator as stipulated in the User Database and are defined by their individual password authority via the User database. (Section 5.6.)

Control functions set in the Panel database are accessed by the workstation operator via the various MAESTRO system operating controls, for example the panel controls box, the panel fascia simulation display or panel and device information cards.

#### 5.4.1. Panel database input screen

The Panel Database input screen is accessed by clicking onto the Panel database page tab located in the row running across the top of the display.

On accessing the screen, the database title appears in the bar across the top of the database display.

The screenshot displays the 'Panel Database' input screen. At the top, there is a title bar with 'Panel Database' and a set of navigation buttons: First, Prior, Next, Last, Edit, Post, Cancel, and a Done button with a green checkmark. Below the title bar, the screen is organized into a grid of six panel configuration panels, numbered 1 through 6. Each panel has a 'Panel No' field, a 'Panel Name' text box, a 'Panel Type' dropdown menu (set to 'None'), and a 'Connection' dropdown menu. Underneath, there are two sections: 'Command Filters' and 'Event Filters'. The 'Command Filters' section includes checkboxes for Poll, Accept, Reset, Silence Alarm, Sound Alarm, Status, Service, Disabled, Gas Status, and Time Set. The 'Event Filters' section includes checkboxes for Fires, Faults, Outputs, Callpoints, and Non-Fires. In the screenshot, the 'Fires' checkbox is checked in all six panels. The first panel (Panel No 1) is highlighted with a blue border.

# Maestro Graphics System

## Maestro Database

### 5.4.2. Panel controls input

Input screens for panel numbers one to six are shown across the major part of the screen. Screens for panels from 7 to 64 can be displayed by using the scroll bar running along the bottom of the display area. A blue border, indicates the accessed screen.

The panel name may be typed into the windows provided. This will be the name for each panel displayed throughout the MAESTRO system. Therefore care must be taken to ensure that this information is correct and that the definitions are the same as other site references and are those recognised by the workstation operator. Usually the panel name will be the same as the title stored in each panel, as entered in the PLANNER files.

Windows for panel type and the communications port to which the MAESTRO workstation is connected, are provided on the second row of each panel input screen. Appropriate panel type and comms port are selected by clicking onto the relevant type from drop down lists, accessed by clicking onto the navigation button at the right side of either window.

#### Permitted commands

The lower portion of each Panel control input screen provides check boxes for ten control selections. Each function is selected by clicking onto the relevant window. When selected a black tick is displayed. Selections toggle between selected and not selected.

The following permitted commands are available -

1. **Poll.** This instructs MAESTRO COMMS to include the panel in the list of panels, with which to establish communications. Individual panels may on a temporary or permanent basis not be required to be included within the control of the MAESTRO workstation. If a panel is set not to be polled, it will be ignored by MAESTRO and no alarms originating from that panel will be displayed.
2. **Accept.** This allows the workstation to issue the Accept Alarms command to the specified panel. When alarm signals are accepted directly at the panel, the accepted status of the alarm is also sent to MAESTRO and updated on the workstation screen.
3. **Reset.** This resets the panel, returning it to the quiescent or normal state after an alarm condition or system event.
4. **Silence alarm.** This silences all alarms controlled by the selected panel. This function does not reset the system or any outputs operated by alarm inputs. The panel can only be returned to the normal condition by the reset function.
5. **Sound alarms.** This sounds all alarm devices connected to the panel. The function provides evacuation in all areas covered by the fire alarm system. The sound alarms function also provides a resound function, enabling the alarms to be resounded after a system reset.
6. **Status.** Permits MAESTRO to report the current status of all devices and zones from the specified panel. If selected, this command will automatically be sent to the affected panel ten minutes after the panel has reported that it has been reset. The status includes any fire, fault, service or disabled states.
7. **Service.** This function enables requests from the MAESTRO workstation for the List of devices in the service state requiring routine cleaning maintenance.
8. **Disabled.** Permits MAESTRO to request the list of devices and zones that are partially or fully disabled from the specified panel. The list will include any disabled outputs. If selected, this command will be automatically sent by MAESTRO after the panel has reported that it has been reset.

# Maestro Graphics System

## Maestro Database

9. **Gas status.** This function enables current information on the gas status of all gas control units to be sent by the panel to the MAESTRO workstation and their icons updated. If selected, this command will be automatically sent by MAESTRO after the panel has reported that it has been reset.
10. **Time set.** The time set function permits MAESTRO to synchronise the panel clock with the MAESTRO workstation clock.

### Event filters

Events can be filtered by checking each required filter. MAESTRO can emulate a range of devices to provide for remote control of output devices, attached to panels. The event filters control the type of operation permitted by MAESTRO.

### Navigation toolbar

The Panel navigation tool bar appears across the top of the screen display and provides the following database functions -



### Exit from the database

On the completion of data input or editing, the operator can move to any of the other MAESTRO databases by clicking onto the appropriate database tab from the row displayed at the top of the screen display, or return to the main MAESTRO programme Home Page, by clicking on the Done button at the top right of the screen display.

# Maestro Graphics System

## Maestro Database

### **5.4.3. Exit from the database**

On the completion of data input or editing, the operator can move to any of the other MAESTRO databases by clicking onto the appropriate database tab from the row displayed at the top of the screen display.

Alternatively the workstation display can be returned to the main MAESTRO programme Home Page, by clicking the Done button shown at the right end of the navigation toolbar. If any changes have been made to any of the databases, the workstation user will be prompted to make a backup copy of the data before closing down the configuration editor. It is recommended that this option is always taken to keep the database files as up to date as possible.

# Maestro Graphics System

## Maestro Database

### 5.5. Icon database

#### 5.5.1. Icon database input screen

The icon database editor is used to create zone and device icons. It allows properties to be assigned to each fire alarm state for each zone or device type. Controls and settings for each icon are appropriated to each tag address by selecting the icon type in the tag database.

The Icon Database is supplied with a range of standard icons as well as facilities for the development of custom icon designs.

The screen is accessed by clicking onto the Icon Database tab along the top of the main database displays.

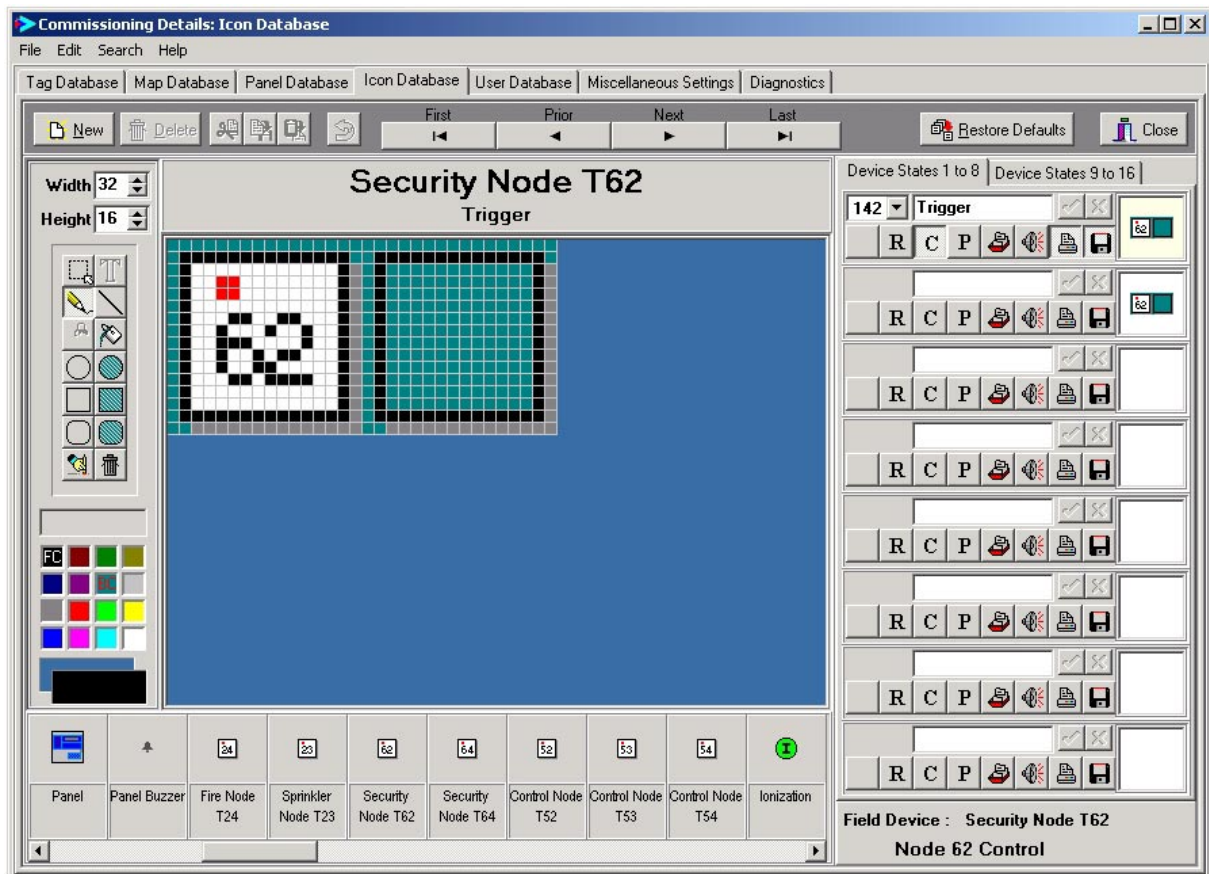

#### Control node functions

These functions have not yet been implemented.

#### Control Node Icons

7 new icons have been added to the standard icon set to provide for the Node Control function present in the ZCP2V3 protocol. These icons are "control only" and should not be used as state display icons since they don't reflect any alarm states.

# Maestro Graphics System



























## Maestro Database

### 5.5.2. Main icon screen

The main area of the icon database screen provides a workspace for viewing standard icon designs, or for creating a set of custom designed icons.

#### 5.5.2.1. Standard icons

The MAESTRO software provides a full range of zone and device icons as shown below.

	Zone		Interface sprinkler		Gas control unit
	Panel Control		Interface general		Sounder driver
	Maestro Terminal		Interface conventional		Addressable LED
	Maestro Dongle		HS aspirating smoke		Line sounder
	Ionisation		Interface conventional		Interface non fire
	Heat fixed temperature		Line relay		Input monitor
	Heat rate of rise		Callpoint		Interface control switch
	Optical smoke		Paradigm multisensor		755 Line sounder
	Suggested usage of panel buzzer icon		Optical heat		Panel buzzer

The illustration on the previous page shows the range of standard MAESTRO icons depicting hardwired components. Similar standard icons are used to depict other component types, for example radio fire alarm equipment and intrinsically safe systems.

The icon appearance and properties attributed to its various states, is global. All settings and controls for a particular device type, for example a smoke sensor, are the same throughout the MAESTRO system. If a smoke sensor is given the property of having its change of state from normal to pre alarm printed out on an attached printer, then all smoke sensors of the same type will behave in the same manner.

# Maestro Graphics System

## Maestro Database

MAESTRO displays the zone or device icon in different colours for different alarm states. Each icon type is displayed as either flashing, prior to alarm acknowledgement, or steady when an alarm signal has been accepted by the workstation operator. To produce this visual effect, the icon changes between an opaque image, shown on the left half of the icon database viewer, to a partly transparent one depicted on the right half of the viewer.

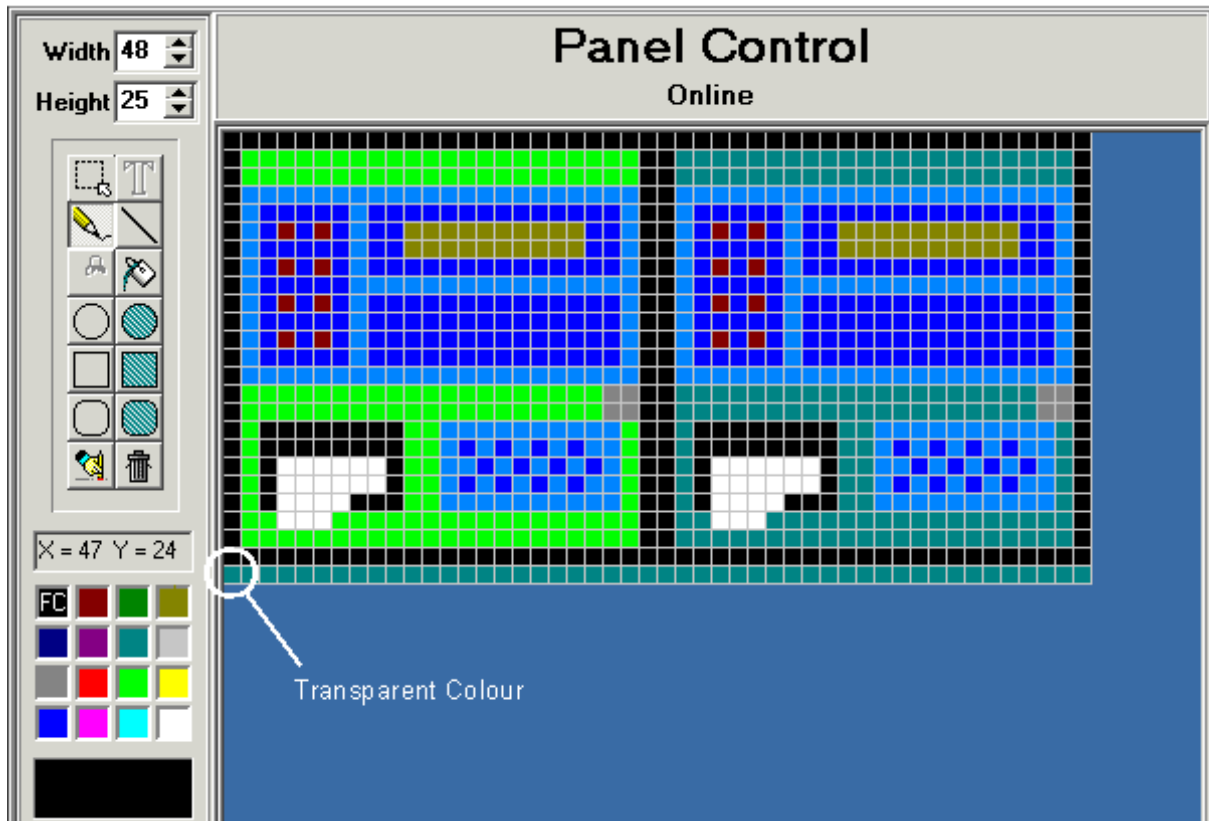

The icon design layout is displayed in the viewer, as a pixelated grid area, with the icon type and state shown above the display. The parts of the image to be displayed transparently are selected by colour. Whichever colour is assigned to the bottom left corner pixel on the viewer, then all pixels of that colour will be shown transparently, in order to produce the flashing alarm effect.

### 5.5.2.2. Custom icons

On the left side of the viewer is a set of tools and functions for creating and changing the appearance of the icons.

Generating custom icons is explained in detail in Section 5.5.6.

### 5.5.3. Icon index

The icon index runs horizontally along the bottom of the icon screen display. Any current icon design, either standard or custom, can be viewed in the Viewer and Device Property Editor (Section 5.5.4.), by scrolling the index to the required design and clicking onto the icon image. The selected icon design will then appear in the icon viewer and Device Property Editor screens.



### 5.5.4. Device property editor

The Device Property Editor provides the means to set the properties of each icon for each state that the icon can display. The properties include the state name, alarm, print, logging and audible alert functions, reset state, persistent state and control function. MAESTRO permits a maximum of 16 possible states for each icon.

The editor is displayed down the right side of the screen display.

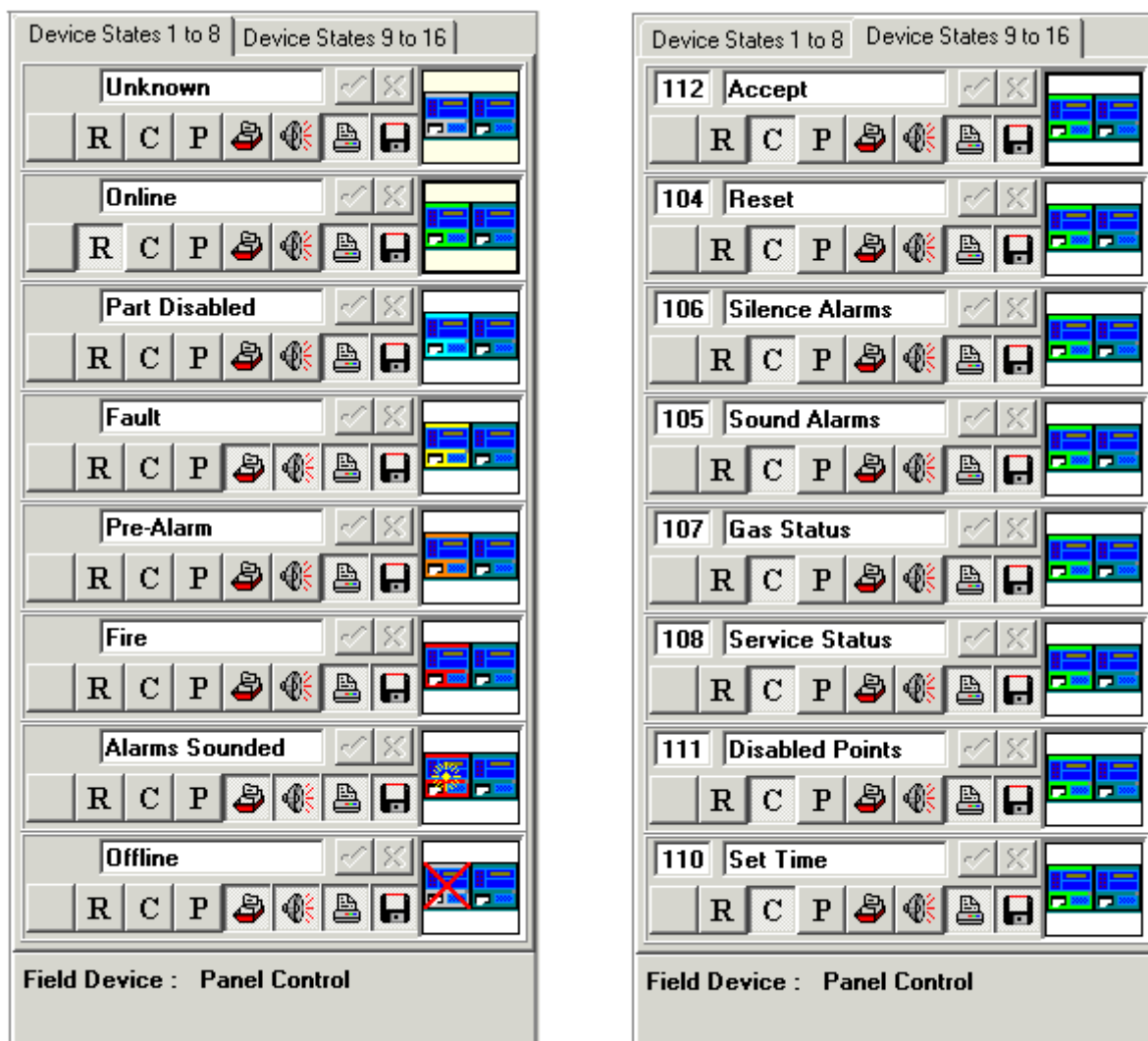

In any alarm state the MAESTRO workstation operator can display information cards for any device, by clicking onto the appropriate icon (see User Guide Section 6.3.) . An information card is displayed (for the current device alarm state) upon which may be included control functions. The Device Property Editor is used to determine which functions and controls are available from each icon type.

For each device type displayed in the icon viewer, the editor displays a list of state boxes each named with a device state. Options are selected from a row of buttons displayed under each alarm state name.

# Maestro Graphics System

## Maestro Database

Device states 1 to 8 correspond to typical alarm states generated by the devices and zones on the panels, for example fire, fault, disabled. Device states 9 to 16 are usually used for additional control functions. Alarm indications and control states should be kept separate to avoid confusing event reports in the Event Log.

Different device types have differing numbers of possible alarm states, for example a simple relay switch could be on, off, disabled or in a fault condition, whereas a control panel would have many more possible levels of alarm states.

When an icon type is selected in the icon viewer, all its device states are listed in the device property editor boxes. Each state is named and an actual size diagram of the icon is shown at the right end of the selection box.



The following properties can be selected, by choosing the state and clicking onto the appropriate button.



**Reset.** Clicking this button, in the appropriate box, selects the state the device will be set to on system reset. This will usually be the normal or quiescent non-alarm state.

Devices which are reverse acting (ie normally in alarm) will have their reset state enabled on an alarm state.



**Control.** This attribute indicates that the selected state is a control function that MAESTRO can send to a panel. Typical controls are disable and enable, but other possibilities exist (see Appendix A).

When a control function is selected, a window is presented at the top left of the state selection box, displaying the control code number.



**Persistent.** This attribute indicates that the selected state persists across system resets. Its function mimics device and zone states that do not reset when the panel resets, for example disablements or latched outputs.



**Alarm List.** Clicking this button includes the device at the selected state in the alarm list (see Users Guide Sections 2.5. and 2.6.).

*Note: The Alarm List option (above) must be selected for the alarm state, before the Workstation Alarm function can be enabled.*

# Maestro Graphics System

## Maestro Database



**Workstation Alarm.** Selecting this button sounds an audible warning at the workstation, when the device enters the selected state.

*Note: The workstation must be fitted with sound facilities.*



**Printer.** This option prints the selected alarm state to an attached printer.



**Event Log.** Clicking this button records the device entering the selected state and holds the event in the event log.

Positioned below the Device State Editor, at the bottom right of the screen, is the field device information area. This small panel provides the name and code numbers for the device currently displayed in the icon database.

The alarm state inputs for any device type can be returned to the original default by clicking the Restore Defaults button at the top right of the database screen display.

### 5.5.5. Zone property editor

Indications and functions can be assigned to the various alarm states on a zone basis, by a similar method to that applied to devices.

On the selection of the zone icon in the device state editor, a zone alarm state list is displayed down the right side of the screen. This display is used in a similar way to the Device Property Editor detailed in Section 5.5.4.

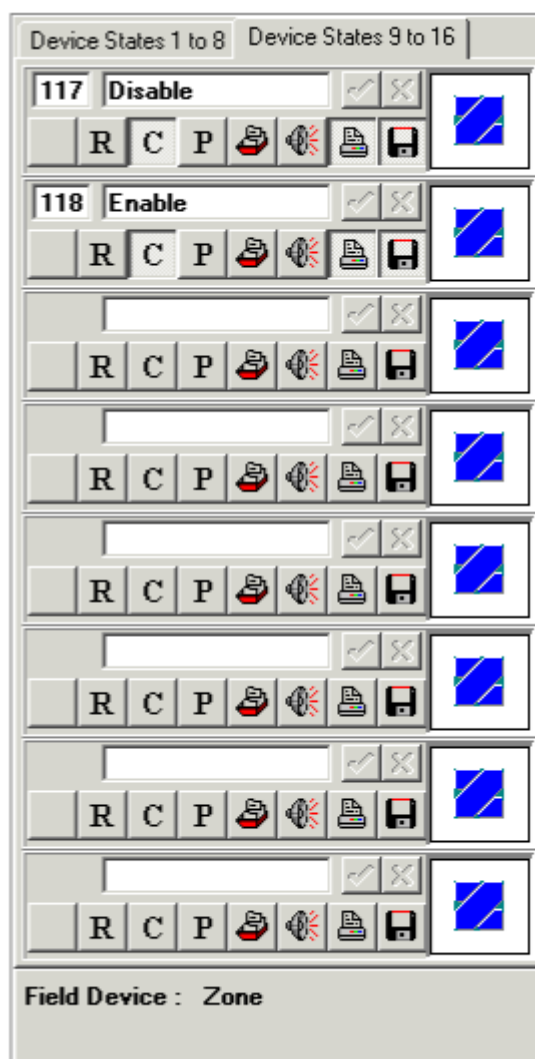
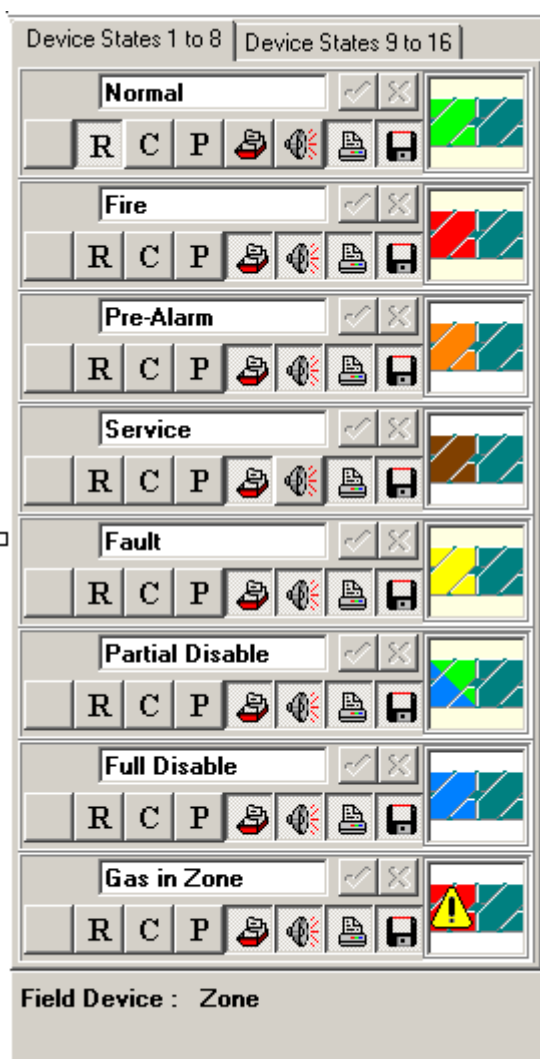

The options offered in the zone property editor, enable zone information cards to provide indication of the zone alarm state and offer zonal enable/disable control features.

It is important to note that the zonal alarm state changes with a change of any single device or devices assigned to the zone. If one sensor or manual call point changes alarm state, then the whole zone changes to that state.

When a zone is assigned enable and disable controls from the zone property editor, every device in that zone will be enabled and disabled from the MAESTRO main programme information card.

# Maestro Graphics System

## Maestro Database

When only some of the devices in a particular zone are disabled, the zone will be partially disabled and will be shown as a bi-coloured icon. When all devices in the zone become disabled, then the zone will become fully disabled and the zone icon will change to the full disable state.

### 5.5.6. Custom icons

The editing functions offered in the Icon Editor screen enable standard icons to be modified, additional designs to be added to the standard sets, or the generation of a completely customised icon range.

Icon alarm states can be renamed and a variety of indication and control functions selected for operation on specific alarm states.

#### 5.5.6.1. Icon design

The Icon Viewer Area is displayed as a grid, enabling the system designer to draw in any design. The viewer area is shown below.

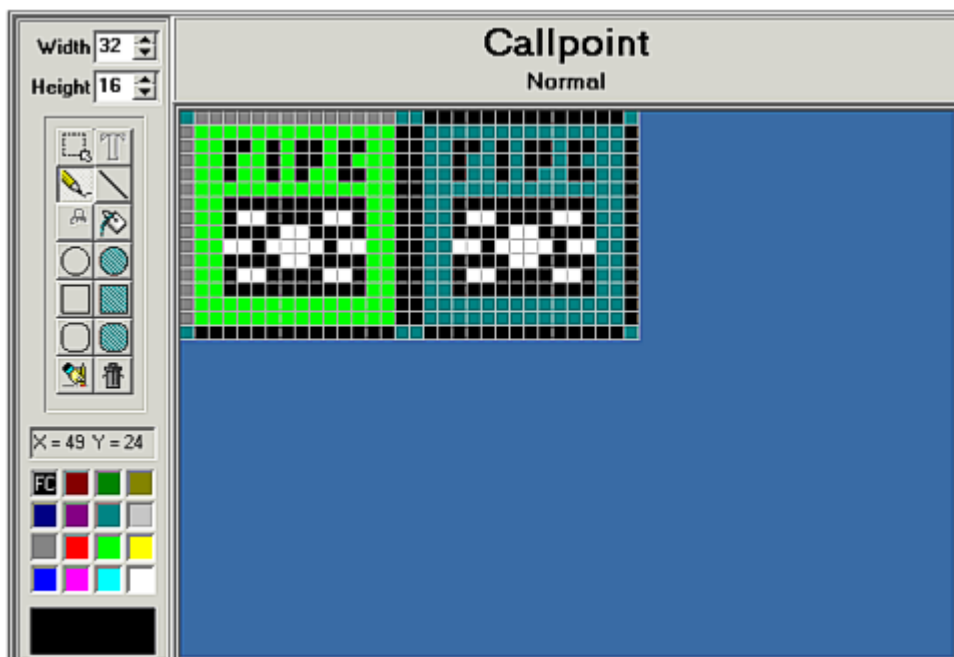

The Viewer Area is divided into two sections.

1. **Grid Display.** The display consists of a pixelated grid upon which any icon design can be drawn. Where icons are required to flash on alarm, the icon design must be centrally split with the full image laid out in the left half of the grid and the elements of the design intermittently assuming transparency (in order to produce the flashing effect) drawn in the right half.

The transparent pixels, are selected by colour. All pixels given the same colour as the pixel at the bottom left corner of the grid will become intermittently transparent in alarm, when displayed on the workstation screen. Note that the left half of the image may also have transparent parts.

2. **Drawing Tools.** The column down the left side of the Viewer Area provides the following functions.
  - i. *Grid size control.* The size and aspect of the viewer grid can be selected from the width and height controls, up to a maximum of 50 x 32 pixels.

# Maestro Graphics System

## Maestro Database

- ii. *Drawing tools.* Drawing tools are selected by clicking the appropriate button.
- iii. *Pixel co ordinates.* The cursor position is always displayed in this window by x and y values.
- iv. *Colour pallet.* 16 standard colours are displayed and are applied by clicking onto the colour then applying to the grid area via the drawing tools.

The colour in use is displayed in the larger window indicated on the pallet with the letters FC (foreground colour). The colour in use is also displayed in the larger window below the pallet.

By double clicking onto this larger window, further colours, with custom options become available

On completion of the icon for each alarm state in the series, the design must be posted to the MAESTRO database memory by clicking the Post button (marked with a tick) located alongside each of the Device or Zone Property Editor windows. The button marked with a cross cancels the design currently displayed in the icon viewer.

### 5.5.6.2. Importing icon designs from other programmes

Icon designs can be imported into the MAESTRO programme, from other software drawing or image packages, enabling designs existing in other site programmes to be reproduced exactly.

Photographic representations can be imported, provided that they are generated from a compatible programme and the overall image size falls within the maximum grid size of 50 x 32 pixels.

### 5.5.6.3. Custom icons - alarm state indications and controls

In addition to the appearance of the icon range, alarm states associated with each of the fire alarm devices represented by the icons can be retitled (from the standard versions) and a variety of indications and controls can be assigned to particular alarm states.

The alarm state, for example the standard 'Alarms Sounded' could, to perhaps fit in with site terminology, be changed to display the word 'Evacuated'. Any alarm state title can be changed in this way by clicking onto the appropriate window, in the Device state editor and typing in the custom title. On clicking onto the window the two boxes for posting or cancelling the change become highlighted and must be operated to complete the title change. Changing the name only changes the displayed name throughout the MAESTRO system, it does not alter the operation of that state within the system.

The Post and Cancel buttons are also used when inputting custom icons (Section 5.5.6.1.)

Indications and controls can be attributed to any device alarm state, where the resulting action is a possibility within the fire alarm system. A three digit code number is used to communicate control functions between MAESTRO and the fire alarm control panel. By clicking onto the "C" button, a window is displayed to the left of the title field, into which the chosen control function code number must be entered.



A full listing of the control code numbers is included in Appendix A. Note that only the numbers listed may be used, any other number will be ignored.

### 5.5.7. Navigation and editing toolbar

The icon database toolbar runs horizontally across the top of the screen display, and is primarily used in generating custom icons.



The tool bar provides the following functions.



**New button.** Creates a new custom icon and alarm state series in the database.



**Delete button.** Highlighted once the New button has been operated, deletes current icon input. Standard system supplied icons cannot be deleted.



**Cut, copy and paste buttons.** Enables normal cut copy and paste functions to be applied to the icon design grid. For example once a custom icon design has been completed for one alarm state, it can be copied to form the basis for other states, prior to colour changes. Cut and copy requires a selection to be made from the icon image.



**Undo button.** Cancels the last input action.



**First, last, prior and next navigation buttons.** Navigates through the icon index, displayed horizontally along the bottom of the main display.

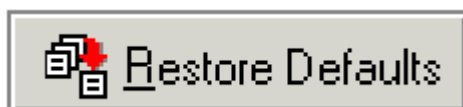

**Restore Defaults.** Restores changed information to the default values for the standard set of MAESTRO icons. This has no affect on any custom icons.

# Maestro Graphics System

## Maestro Database



**Done.** Closes the icon database screen and returns the user back to the main MAESTRO operating programme.

Clicking the Done button prompts the user to back up any changes to the icon database.

### 5.5.8. Exit from the database

On the completion of data input or editing, the operator can move to any of the other MAESTRO databases by clicking onto the appropriate database tab from the row displayed at the top of the screen display.

Alternatively the workstation display can be returned to the main MAESTRO programme Home Page, by clicking on the Done button shown at the right end of the navigation toolbar.

If any changes have been made to any of the databases the workstation user will be prompted to make a backup copy of the data before closing down the configuration editor. It is recommended that this option is always taken to keep the database files as up to date as possible.

## 5.6. User database

The user database holds the name and password for every user of the MAESTRO system. It also holds the permissions list for each user and enables the commissioning engineer to select which control are available for individual MAESTRO operators.

### 5.6.1. User database input screen

The User Database Edit screen is accessed by clicking onto the User database page tab located in the row running across the top of the display.

On accessing the screen the database title appears in the display bar across the top of the screen.



# Maestro Graphics System

## Maestro Database

### 5.6.1.1. Silent Operation

#### Feature

To be used at the time of initial site commissioning when staff require Maestro audio alarms to be muted.

**Note:** *Ensure that this setting is not selected for normal operation.*

#### Procedure

To enable mute of Maestro audio alarms select the Silent Operation tick box.

User Name	Password	Verify Password	Silent Operation
Installation User	*****	*****	<input checked="" type="checkbox"/>
Mike	*	*	<input checked="" type="checkbox"/>
Maestro	***	***	<input checked="" type="checkbox"/>

# Maestro Graphics System

## Maestro Database

### 5.6.2. User information

For each user three sections of information need to be filled.

#### 5.6.2.1. User name and password

Space is provided to enter the user name, their password and a password verification.

Passwords may be up to a maximum of any ten upper or lower case characters and/or numbers and spaces and are case sensitive.

The operator will be prompted by MAESTRO when a password is required in order to access a particular area of information or perform specific systems tasks (Section 5.1.1. MAESTRO user guide).

User information including passwords, can be changed at any time by anyone with access to the user database. Individual operators can also change their password via the Change Password function (Section 5.1.2. MAESTRO user guide). Passwords changed by the Change Password function are automatically updated in the operators individual user record.

#### 5.6.2.2. Alarm Accept Permissions

Each user can be assigned up to twelve Alarm Accept Permissions, the first six for fire alarm and the lower six for other systems. Each option enables the operator to accept the relevant alarm condition. Options are chosen by clicking onto the appropriate check box. When activated a tick appears in the selected check box. Selections toggle between on and off.

All twelve options are enabled as a default when the file is initially displayed.

If the workstation operator is given the authority to accept alarms in order to provide an initial response to system events, it is most likely that the authority will need to extend to all alarm types, however this need not be the case. Certain alarm types may need supervisor permission to accept.

All alarm acceptances operated under password authority are recorded in the systems Event Log History.

#### 5.6.2.3. System controls

The System Controls area provides selection for six system functions.

1. **Shutdown.** Authorises the user to shut down the MAESTRO system.
2. **Commissioning.** Permits access to the commissioning tools and MAESTRO database.
3. **Empty event log.** Enables the user to erase events from the event log.
4. **Delete memo.** Allows the user to delete memos from the notepad/logbook function.
5. **Edit phone book.** Allows user to add and erase telephone numbers from the MAESTRO telephone list.
6. **Back-up/restore.** Enables the user to back-up and restore database information.

#### 5.6.2.4. Commissioning

The commissioning selections allow the MAESTRO user to make changes to the Tag, Map, Panel, Icon, User and Printer sound and colour settings database inputs.

These are the selections that determine which database screens are displayed to allow access by the users password.

# Maestro Graphics System

## Maestro Database

### 5.6.2.5. Panel controls

The panel controls selections each enable the workstation user to operate the following specific panel functions, Accept alarms, Reset panel, Disable points (callpoints, sensors, interfaces), Silence alarms, Sound alarms and Enable points (devices).

The above areas of authority are grouped together to provide all the functions normally associated with a particular level of responsibility and on most sites are made available as a group of functions.

The user information is displayed in groups of three. A scroll bar is provided down the right hand side of the display to move up or down the User Files list. A black triangular pointer, on the left of the display, indicates the active block.

### 5.6.3. Navigation toolbar

The User File navigation tool bar appears across the top of the screen display and provides the following database functions -

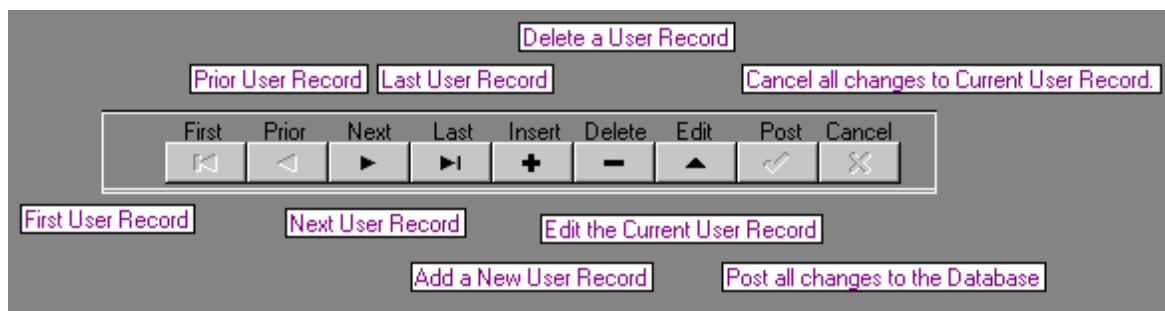

### 5.6.4. Exit from the database

On the completion of data input or editing, the operator can move to any of the other MAESTRO databases by clicking onto the appropriate database tab from the row displayed at the top of the screen display, or return to the main MAESTRO program Home Page, by clicking on the Done button at the top right of the screen display.

If any changes have been made to any of the databases the workstation user will be prompted to make a backup copy of the data before closing down the configuration editor. It is recommended that this option is always taken to keep the database files as up to date as possible.

### 5.7. Miscellaneous Settings

Printer settings, audible sounds accompanying alarm events, alarm banner text and background colours, are selected and set via the Printer, Sound, and Colour screen.

To provide the variety of supervisory alarm sounds available within the MAESTRO programme, the workstation must be fitted with a sound card to produce the range of alarm sounds.

The database function provides -

1. Settings for printer types and the selection of alarm type to be printed.
2. Sound settings for specifying the audible sounds generated at the workstation, for each class of alarm.
3. Colour and text settings, enabling the user to provide custom alarm banner titles and backgrounds.

#### 5.7.1. Diagnostics tag edit

##### Feature

Allows Maestro to request panels field line configuration and global configuration settings.

##### Procedure

To access this configuration menu navigate as follows:

*Commissioning Details\Miscellaneous settings*

# Maestro Graphics System

## Maestro Database

### 5.7.2. Database input screen

The database input screen is accessed by clicking onto the Printer, Sound and Colour settings database page tab located at the far right of the row running across the top of the display.

**Note:** *If the workstation is not fitted with a sound card, the sound settings group window will not appear.*

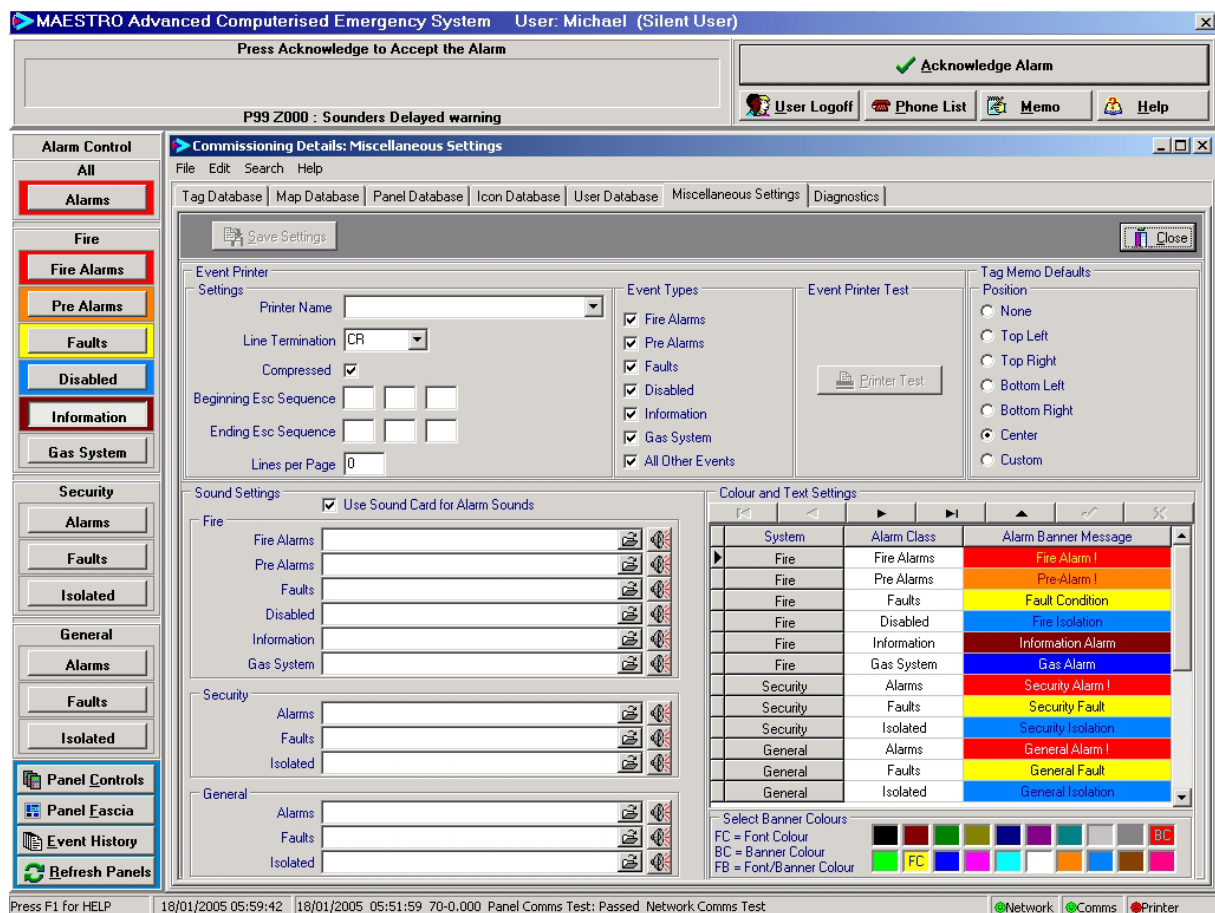

On accessing the database, the title appears in the display bar across the top of the database screen. The Printer, Sound and Colour input display is divided into four separate sections.

1. **Event Printer.** Providing input for printer connections and page layouts, Event selections and printer test function.
2. **Sound Settings.** Enabling the standard default workstation alarm sounds, or providing inputs for custom sound files. Only applicable if a sound card is fitted to the workstation.
3. **Colour and Text Settings.** Allowing customisation of alarm class descriptions, text and background colours for workstation alarm banners, current alarm list entries and alarm list buttons.

# Maestro Graphics System

## Maestro Database

### 5.7.2.1. Event printer database

The Event Printer database input screen runs horizontally across top of the input screen and is divided into three separate areas.

**Settings.** This screen links the printer to the workstation computer, providing the following functions.

Event Printer Settings	Event Types	Event Printer Test	Tag Information
Printer Name: [Dropdown]	<input checked="" type="checkbox"/> Fire Alarms	Printer Test	Position:
Line Termination: [Dropdown: LF]	<input checked="" type="checkbox"/> Pre Alarms		<input type="radio"/> None
Compressed: <input type="checkbox"/>	<input checked="" type="checkbox"/> Faults		<input type="radio"/> Top Left
Beginning Esc Sequence: [ ][ ]	<input checked="" type="checkbox"/> Disabled		<input type="radio"/> Top Right
Ending Esc Sequence: [ ][ ]	<input checked="" type="checkbox"/> Information		<input type="radio"/> Bottom Left
Lines per Page: [0]	<input checked="" type="checkbox"/> Gas System		<input type="radio"/> Bottom Right
	<input checked="" type="checkbox"/> All Other Events		<input checked="" type="radio"/> Center
		<input type="radio"/> Custom	

**Printer Name Window.** Any printer connected to the workstation network can be selected by firstly clicking onto the arrow at the right of the Printer Name window and then clicking onto the required printer name from those displayed in the drop down list, (i.e. those currently connected to the workstation). On selection the printer name automatically appears in the Printer Name window.

*Note: page printers such as normal office laser printers and some types of inkjet printers are inappropriate for use as event printers. Ordinary dot-matrix type printers are preferred*

**Line Termination.** Specifies the characters appended to each text line as required by the selected printer. Options are Line Feed (LF), Carriage Return (CR) Line Feed and Carriage Return (LF/CR).

**Compression.** Select to cause the event printer to use a compressed (17c.p.i.) font.

**Beginning Esc Sequence.** Any additional printer control characters required to format each printed line (see printer manual for details).

**Ending Esc Sequence.** Any addition ending printer control characters required to cancel any special formatting controls (see printer manual)..

**Lines per Page.** Controls the number of printed lines on each page before a page footer is printed, form feed issued and a page banner printed. Determined by the size of the paper used in the printer.

**Event Types.** A listing of event types is displayed running vertically down the input screen. Clicking onto any of the tick box windows selects or de - selects the event type to be included on the event report. These settings only effect the Event Printer. Reports generated from the MAESTRO Event Log are according to the selections made on the Event Log Screen (Section 8.1.5. of the User Guide).

# Maestro Graphics System

## Maestro Database

**Event Printer Test.** Prints a single line of text on the printer to verify the correct printer settings.

On completion of the installation or editing of Printer Settings, changes must be saved by clicking onto the Save Settings Button located at the top of the main input screen.

### 5.7.2.2. Sound settings

The sound settings input screen is located at the bottom left of the main database display. This screen enables the user to access the range of standard or default sounds, sounded by the workstation on the receipt of alarm conditions from the fire alarm system. This feature is only available on workstations equipped with a sound card and speakers.

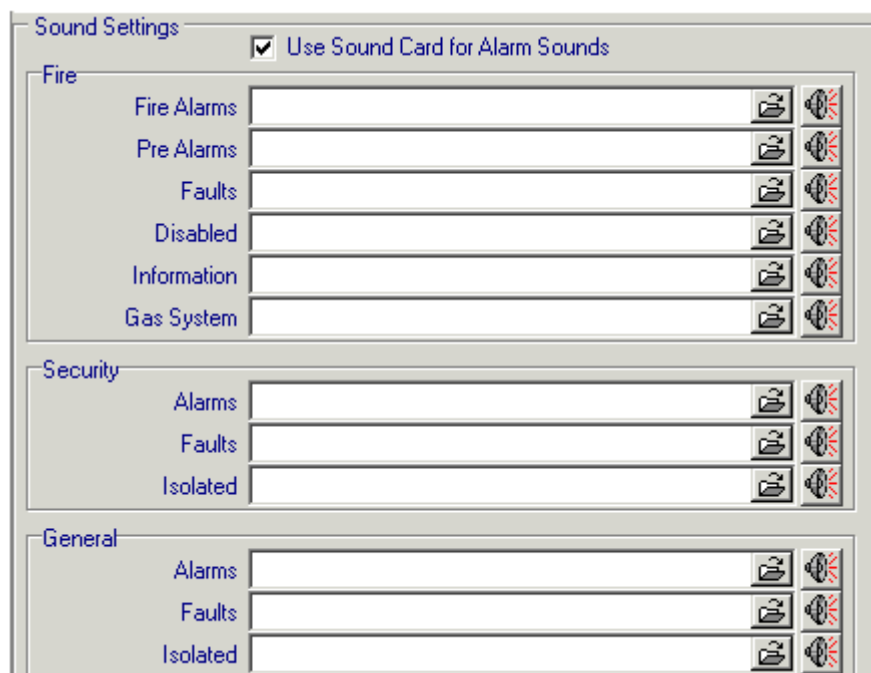

The default range of alarm sounds distinctive for each alarm type is automatically transferred into the MAESTRO database when the operating programme is installed onto the workstation.

The sound setting function however allows the client's own customised sounds to be used, on receipt of each alarm type.

Alarm sounds are configured as follows.

1. **Use Sound Card for Alarm Sounds window.** This Tick Box window located at the top of the Sound Settings part of the display enables the standard or default sounds to be selected or de-selected.
2. **Customised Sound Types.** To install custom sounds from files held on discs, select the Use Sound Card for Alarm Sounds. Located directly below the selection tick box are a series of windows each provided with an Open File button and a Test button.

Clicking the Open File button, displays the current directory of custom sound types, (held on the customer disc). Clicking onto the selected sound file displays its title in the window, against the alarm type name.

Once selected the sound can be tested by clicking the Test button displayed to the right of the Open File button.

# Maestro Graphics System

## Maestro Database

Input is provided for fire, security and general alarm types.

On completion of the installation or editing of Sound Types, changes must be saved by clicking onto the Save Settings Button located at the top of the main input screen.

When an alarm occurs, the specified sound file will be played repeatedly until the alarm is accepted. Beware of using sound files, which are too complex or too convoluted as the effect when played repeatedly may result in an unnecessary annoyance.

### 5.7.2.3. Colour and text settings

The lower right area of the database screen features the Colour and Text Settings input screen.

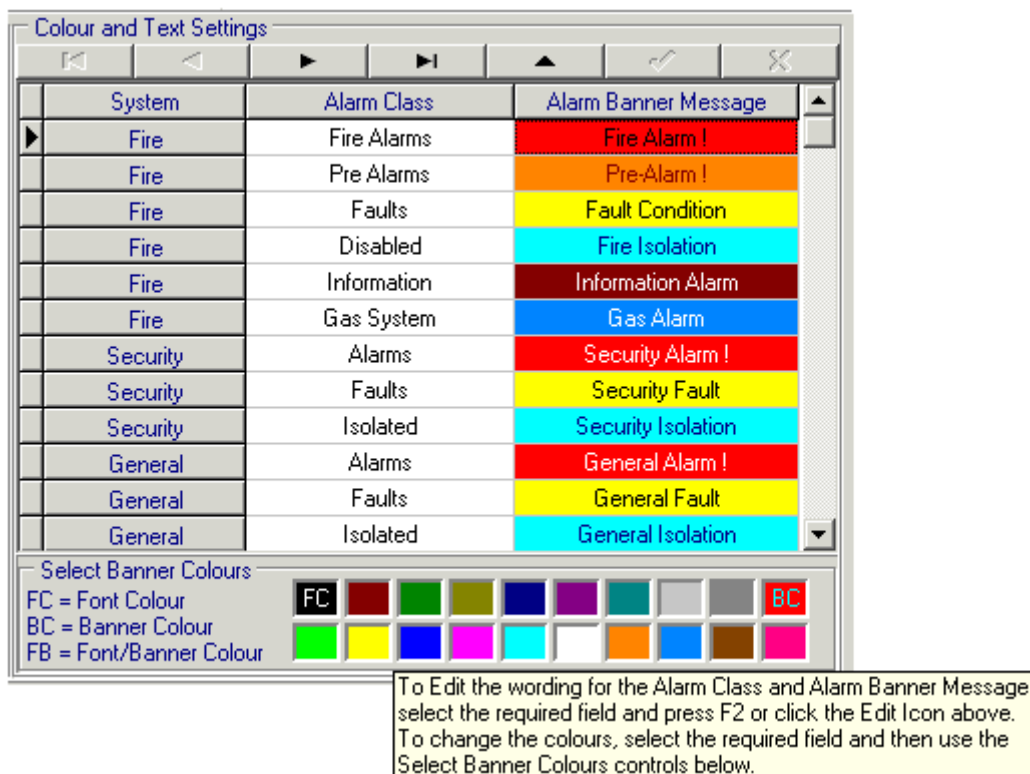

This function enables the user to make changes to the titles of alarm types and change the standard colours attributed to the text and backgrounds of alarm banners, alarm list buttons and alarm type descriptions when displayed in alarm lists on the workstation screen.

The display features three columns.

**System.** Alarm types are listed for Fire, Security and General.

**Alarm Class.** Displays the alarm types displayed by the workstation for each of the above systems.

**Alarm Banner Message.** Shows text and colours of alarm banners for each alarm type.



# Maestro Graphics System

## Maestro Database

The alarm class column allows the alarm type title to be changed. Although any number of characters can be used, names should be kept to a minimum, in order to be easily read by the workstation operator and to ensure that when the title becomes a heading in certain alarm list reports, columns are kept to a practical width.

Alarm type titles are edited by clicking onto the selected name in the Alarm Class column. The title is highlighted and identified by a pointer in the narrow column to the left of the display. A second click opens the window and the new title can be typed in.

After editing the alarm class description the change must be saved in the MAESTRO database, by clicking the post button (displayed as a tick mark), in the navigation toolbar at the top of the Colour and Text Settings display. To cancel a change, click the cancel button (displayed as a cross).

### Select Banner Colours

The Alarm Banner text and background colours can be edited as follows.

Select the Alarm Banner to be edited, by clicking onto the item displayed in the Alarm Banner Message column. A second click opens the window and the new colour can be selected.

To select the text colour, left hand click onto the required colour from the pallet, at the bottom of the Colour and Text Settings display. The text displays the selected colour and the letters FC (font colour) appear on the chosen colour in the colour pallet.

To select the background colour, right hand click onto the required colour from the pallet, at the bottom of the Colour and Text Settings display. The background displays the selected colour and the letters BC (background colour) appear on the chosen colour in the colour pallet. Selecting the same colour for the font and background is possible but not practical.

### 5.7.3. Exit from the database

On the completion of data input or editing, the operator can move to any of the other MAESTRO databases by clicking onto the appropriate database tab from the row displayed at the top of the screen display, or return to the main MAESTRO program Home Page, by clicking on the Done button at the top right of the screen display.

If any changes have been made to any of the databases the workstation user will be prompted to make a backup copy of the data before closing down the configuration editor. It is recommended that this option is always taken to keep the database files as up to date as possible.

### 5.8. Database input sequence

Information can be imported into the MAESTRO database in a variety of sequences. However the following sequence ensures that elements are input in an order that makes full use of the MAESTRO database input functions whilst reducing the amount of work.

In order to successfully complete the database configuration, the following information must be to hand -

1. The fire alarm system PLANNER files - usually stored on floppy disc, or if PLANNER has not been used, printed lists of the devices and zones in the system must be procured.
2. All map files - held on appropriate electronic disc.
3. If custom icons are to replace the standard MAESTRO range, these should be generated and installed in the icon database prior to any database input work commencing.

#### **Stage 1. Information from PLANNER files.**

The fire alarm system information should be installed into MAESTRO from the PLANNER files, as configured at the fire alarm commissioning stage. The information, usually held on floppy discs is downloaded directly into the workstation computer.

#### **Stage 2. Input map files**

Maps should be imported from map files into the Map database. The map directory should be checked against the previously prepared map schedule, ensuring the structure is complete.

#### **Stage 3. Add map navigation functions**

All map buttons, map page buttons and zoom buttons should now be carefully placed onto each map in the directory in turn, via the Map database. On completion each maps links to other maps should be tested.

#### **Stage 4. Zone and device detail**

The Tag database screen can now be completed for each zone and device in the system. The list of tag numbers will be displayed taken by MAESTRO from the PLANNER information. When locating tags to maps the map directory will be displayed as drop down lists, taken by MAESTRO from the map schedule already installed.

The tag information screen for each device and every zone should now be completed.

#### **Stage 5. Check map structure**

The map directory and structure should again be checked, confirming that each tag has been assigned to the correct map.

# Maestro Graphics System

## Maestro Database

### **Stage 6. Check icons**

Icons should now be checked for each device type. Either the standard icon range, or previously completed custom icons, saved in the MAESTRO database. Check that the correct alarm state name and properties are as required.

### **Stage 7. Place icons onto map backgrounds**

Zone and device icons can now be placed onto each map, via the Map Database screen. Zone icons are positioned onto the relevant map backgrounds first. Device icons are then located onto the points maps.

Use the Snap to Grid function to ensure icons are evenly spaced and positioned in level rows. It is often easiest to work down the map structure from level one down to level three.

### **Stage 8. Edit banner and alarm title display**

If standard default Alarm Banner text and background colours and alarm titles and supervisory sounds are to be edited, this should be completed via the Miscellaneous settings screen.

### **Stage 9. Printer settings**

Printer operating parameters can be set from the Printer Settings function displayed on the Miscellaneous settings screen.

### **Stage 10. Complete panel database**

The panel database can now be completed for each panel. MAESTRO numbers the panels in the order of original input. Features and functions can be selected for indication at and control by the workstation user.

Panel function configurations can be tested via the Panel Database Control Centre Screen.

### **Stage 11. Generate user lists**

User information can be captured for each MAESTRO workstation operator. The User database screen allows separate control permissions to be allocated to individual MAESTRO operators.



# Maestro Graphics System Commissioning Manual

## Section 6 Setup

UD1277.6  
Issue 3  
10/01/2005



# Maestro Graphics System

## Setup

### 6.1. Site set up and testing

In order to provide a successful system, with the minimum of site disruption, the majority of the system preparation work should be completed prior to the installation of the workstation hardware on site.

#### 6.1.1. Off site preparations

Most MAESTRO systems are run from a dedicated PC workstation. Whether the project includes the supply of the workstation hardware, or the workstation is to be supplied by the user, the machine should be fully programmed with all databases completed and where possible communication interface options selected prior to delivery to site.

If possible the workstation should be tested off site, by connection to a control panel. Teething problems which may appear serious in situ, often take on a far lesser significance away from site where time is available to check any unsuspected effects of the specific site selected options.

It is most important that all databases are complete prior to arriving on site. A busy control centre, or the period of time prior to a new building being handed over to clients, can often be the least suitable environment for the input of detailed information.

All database information should always be backed up within the MAESTRO workstation. In addition the complete database contents should be copied to an appropriate medium, with copies held by both client and supplier. This provides a high level of security should the database information ever become lost or damaged and enables efficient maintenance and update of the system. It also provides the supplier with accurate records of the original facilities, should the workstation subsequently become modified by the user.

#### 6.1.2. On site activity

The minimum possible preparation should be left for completion on site. The position and location of the MAESTRO workstation should have been agreed during initial site surveys.

Where possible the loaded workstation should be taken to site complete and connected to the fire detection and alarm system (or network) as detailed in Section 6.1.3.

British Standard BS 5839 Part 1 :1988, recommends a 'responsible person' be appointed, by the owner, to take charge of the fire detection and alarm system and this responsibility must be extended to cover the operation of the MAESTRO equipment. The responsible person need not necessarily be the operator of the MAESTRO system, but someone with an overall responsibility must be nominated.

# Maestro Graphics System

## Setup

### 6.1.3. Hardware connections

The MAESTRO workstation is seen by the fire alarm system as another control panel and is connected to either a single panel or multi panel, peer to peer network in an identical way.

The following hardware is required to connect the MAESTRO workstation to the fire alarm control panel. Note that more than one MAESTRO may be connected to the same peer to peer network, but will be assigned different node numbers.

1. **ZG485 Plug in card.** This is installed into the workstation and provides communication to the fire alarm via RS485 protocol. The card sources power from the PC and couples directly into the workstation communications port (COM1 or COM2).
2. **ZP3AB-NET1 RS485 network board.** The PCB is installed into the ZP3 fire alarm control panel, connecting the MAESTRO equipment to the fire alarm system.
3. **DONGLE-M.** A software protection device 'Dongle' is connected directly into the parallel port between the printer and workstation PC. Without the installation of the dongle, the MAESTRO system will operate for a short period of time in demonstration mode only.

TYPICAL MAESTRO PEER TO PEER NETWORK CONFIGURATION

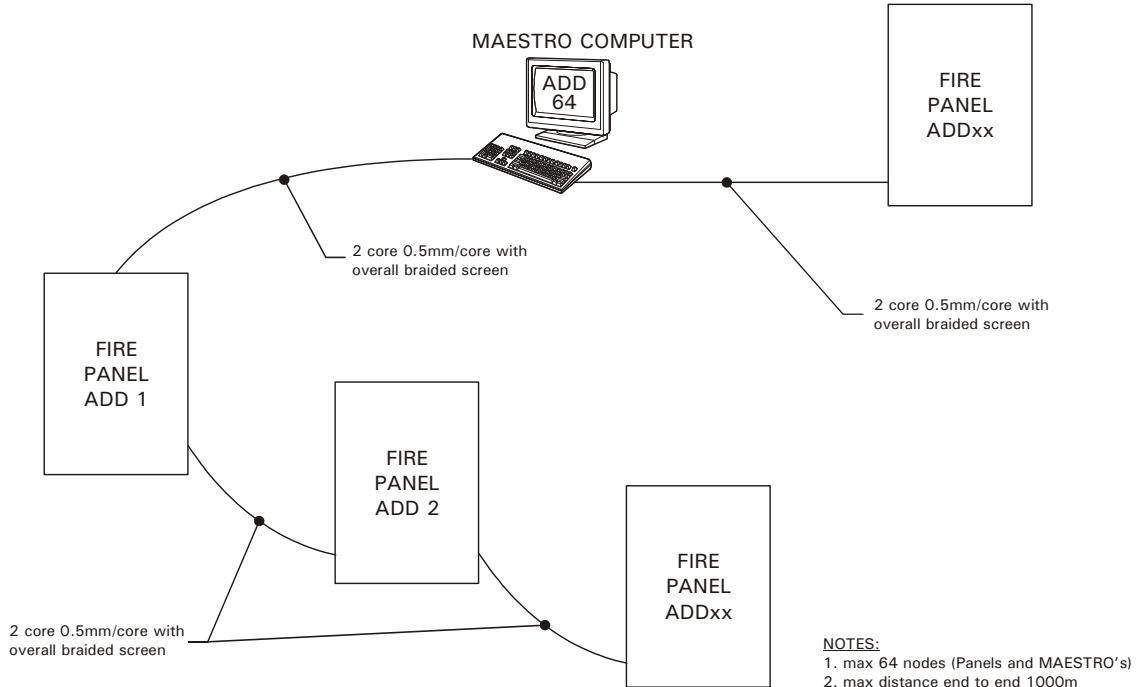



# Maestro Graphics System

## Setup

### 6.1.3.1. ZG485 card installation

The ZG485 card is installed into the workstation as follows.

1. Ensure the workstation pc is disconnected from the power supply.
2. Set SW1 on the ZG485 card as shown below.

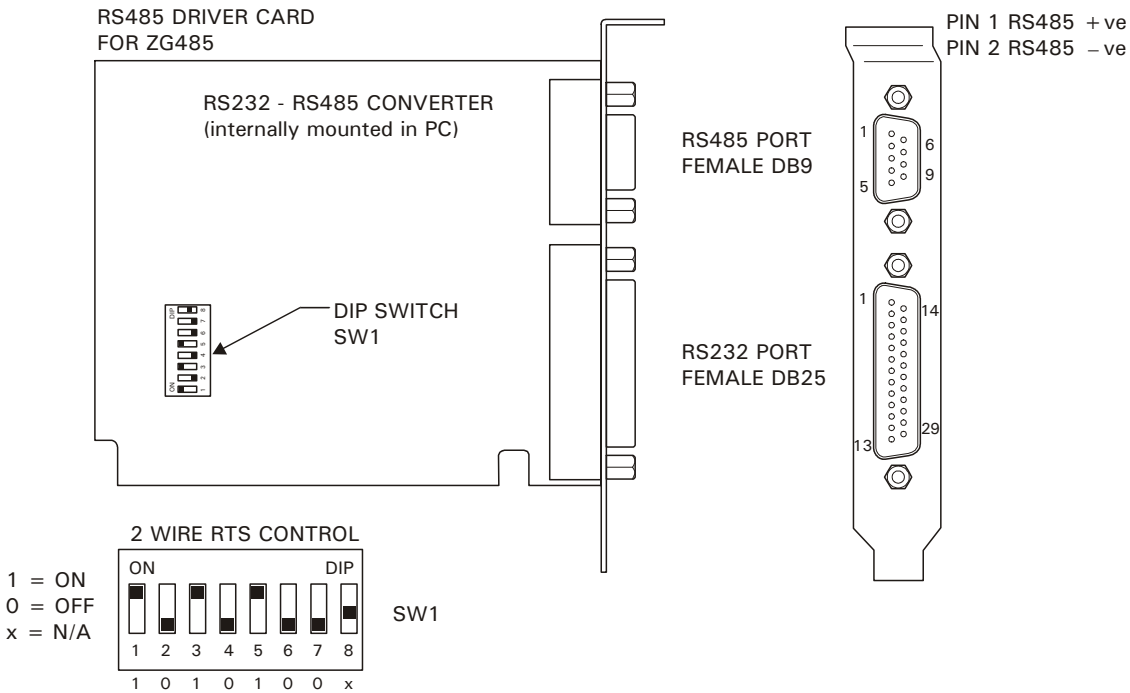

3. Remove the cover of the workstation and locate a spare ISA port. Remove the blanking plate and install the ZG485 card. Note that the card is 'keyed' and must not be forced into place.
4. Secure the ZG485 card with the screw from the blanking plate
5. Replace the workstation cover.

# Maestro Graphics System

## Setup

6. Connect the ribbon cable supplied with the ZG485 card between COMMS2 and the ZG485 card as shown below.

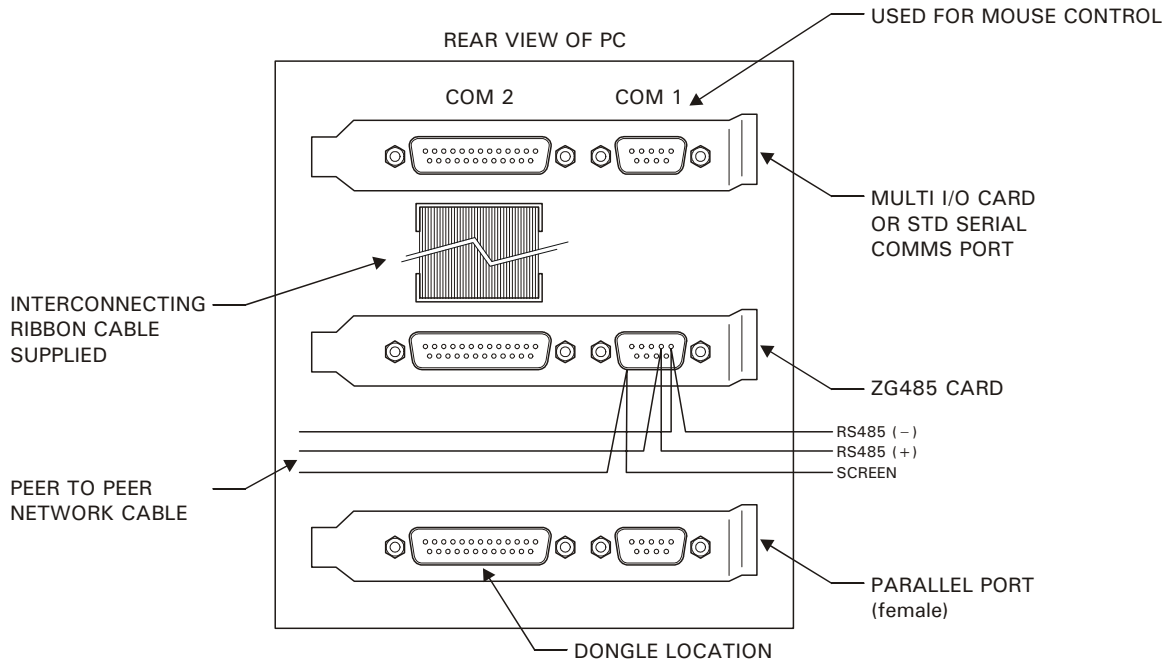

**Note:** *The screen should be connected to the PC chassis via the metal shell of the DB9 connector.*

7. This completes the ZG485 card installation.

### 6.1.3.2. Mouse connection

By default MAESTRO utilises COMMS1 for the mouse connection. The mouse is connected directly into the port via the DB9 connector. On more modern systems a PS2 or USB mouse may be supplied, allowing COM1 to be used for serial communication.

### 6.1.3.3. General configuration

The ZG485 is set to operate in a 2 wire RTS control mode on the RS485 network of the fire alarm control panel system. A maximum of 64 fire alarm control panels and MAESTRO's provided only that each one is uniquely numbered, can be connected onto the network.

With the SW1 switch set as detailed in 6.1.3.1. Paragraph 2. connection of the network cable to the workstation is by a Male DB9 connector.

1. Pin 1. of the DB9 connector is soldered to the RS485 negative.
2. Pin 2. of the DB9 connector is soldered to the RS485 positive.
3. The screen of the network cable should be connected to the workstation chassis. If the workstation is between panels, screen continuity must be maintained. On some sites, problems with earth loops may occur if the screen is connected to the MAESTRO workstation. If these problems are encountered, the services of an electrician may be required to resolve the earthing disparities. If the screen is disconnected from the PC there may be a risk of damaging the ZG485 card if large voltage differences exist between the panels and the PC. Such

# Maestro Graphics System

## Setup

occurrence must be investigated and adequately resolved before MAESTRO will successfully operate.

4. The RS485 network cable is terminated via a ZP3AB-NET1 network card at the selected fire alarm control panel (preferably at the end of the network). See fire alarm control panel manual.
5. The RS485 network should be set to operate at 9600 baud rate, or as high as possible given the limitations of the cables, on all fire alarm control panels (Section 6.1. Site set up and testing).

### **6.1.3.4. Software settings**

As the COMMS Port 2 has been hardware connected to the ZG485 card (Section 6.1.3.2.), all COMMS2 settings are transferred automatically to the ZG485 card.

These settings are all configurable within the MAESTRO 'Set up communications Menu' and detailed in (Section 3.4.2.1.).

MAESTRO 'peer to peer' software is designed to run at up to 56K baud, using 8 data bits, even parity and 1 stop bit, utilising COMMS Port 2 of the workstation to interface onto the network.

The MAESTRO workstation can be assigned any address from 1 to 64 within the network, with the default location being address 64. Double addressing is not permitted.



# Maestro Graphics System Commissioning Manual

## Section 7 Maintenance

UD1277.7  
Issue 3  
10/01/2005



### 7.1. System update and maintenance

Detailed recommendation for the maintenance of fire detection and alarm systems is given in general in British Standard BS 5839 Part1 : 1988. Code of practice for system design, installation and servicing and in particular in the relevant ZP3 control panel manual.

The person on site nominated as the responsible person for the system, should add further responsibilities to the site maintenance schedule, to ensure that the MAESTRO part of the system becomes updated whenever there are modifications made to the fire alarm system itself.

The major areas most likely to require attention are as follows.

1. **Addition and removal of devices.** On larger sites the fire alarm system is continuously being modified in response to changes in building structure and use. This usually involves changes in sensor positions, sensor types, call point locations and the general renaming of specific site areas.

MAESTRO is designed to be easily updated, via its database structure. The system can also be configured to accept untagged events (Section 3.4.1.1.), that is signals from devices assigned to control panels, but not entered onto the MAESTRO system.

Provision should be made for the input of new site data into the relevant MAESTRO databases, as part of the official site procedure whenever a device is effected or a structural description changed.

2. **Addition of new panels or new wiring loops.** When additional areas are added to the original fire detection and alarm system it invariably involves the addition of new maps to cover the increased areas. Care should be taken to ensure that additional maps are produced in a similar style and scale as the original set.

New maps should be compared with the existing map structure to ensure that navigation both within the extended areas and across to the original maps are logical and appear seamless.

3. **Standard and custom icons.** MAESTRO will automatically assign the device type icon design, held in its database, for all new devices of the particular type. That is, the identical icon design will be assigned to all new optical smoke sensors, as that held in the icon database for existing optical smoke sensors.

Changing an icon design changes it globally throughout the fire detection system, effecting both new and existing devices.

4. **Name changes.** Perhaps the most common system modification is the change or renaming of parts of the protected areas. Any name change, especially where the name of the building area forms the location point of the fire alarm device, must be updated within the MAESTRO system immediately any site change takes place. It should be general practice when designating office or zonal descriptions during the original configuration of the fire detection system to, where possible, avoid the use of persons names.

The overall importance of accuracy in the displayed information is obvious, if the MAESTRO system is to be used with total confidence by the operator, especially on sites where some areas may not be familiar to the user.





# Maestro Graphics System Commissioning Manual

## Appendix A

UD1277.A  
Issue 3  
10/01/2005



# Maestro Graphics System

## Appendix A

### Appendix A1: Alarm state control code numbers

A variety of control functions can be assigned in the Device Property and Zone Property Editors to operate from device icon and zone icon information cards, as detailed in Sections 5.5.4, 5.5.5 and 5.5.6.3. Each request is communicated by MAESTRO to the fire alarm panel by a three digit number. The directory of codes is listed below.

- 104** Resets the Panel.
- 105** Sounds evacuation.
- 106** Silences alarm sounders.
- 107** Sends a request to the panel to update the status of gas control panels and updates all gas panel icons.
- 108** Sends a request to the panel for a service report on all sensors and updates all sensor icons.
- 109** Requests a status report from the panel and updates all sensor and zone icons.
- 110** Sets the panel clock to the MAESTRO clock.
- 111** Sends a request to the panel to re-send a list of all disabled zones, devices and outputs.
- 112** Sends a request to the panel to accept an alarm condition.
- 117** Disables a device or zone.
- 118** Enables a device or zone.



# Maestro Graphics System Commissioning Manual

## Appendix B

UD1277.B  
Issue 3  
10/01/2005



### Appendix B1: Preliminary operations - Windows NT

1. Create a NEW USER, which will be the usual Windows NT Logon user.  
Logon as "Administrator" with the appropriate password.  
Select and Run : Start Menu / Administrative Tools (Common) / User Manager.  
Select : User / New user.  
Enter a new user name, e.g. "Operator". If this user is always required to logon to Windows NT with a Password, then enter the initial logon password.

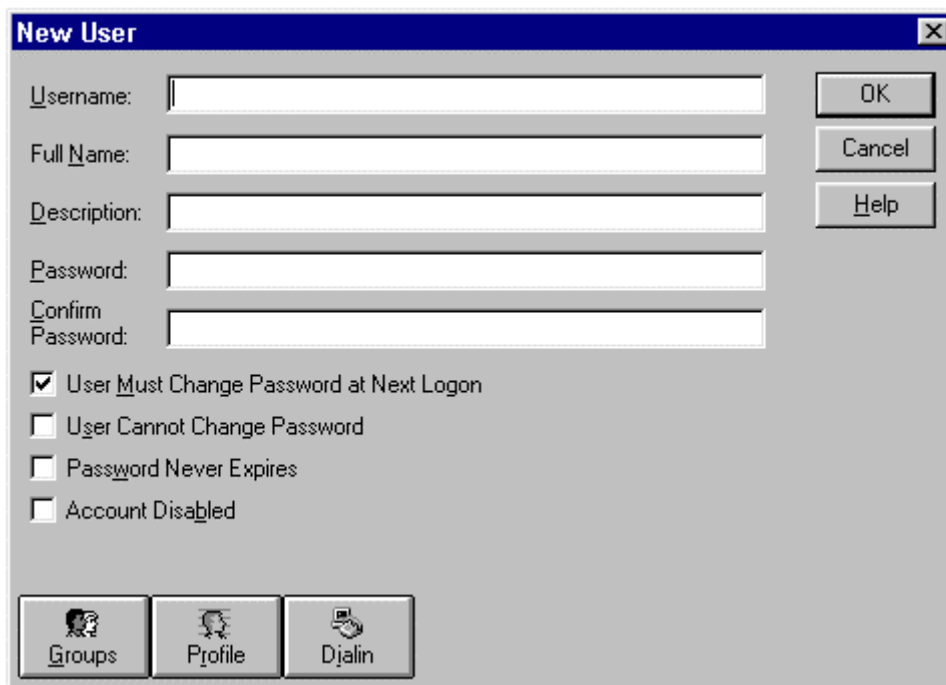

Set "User Must Change Password at Next Logon", "User Cannot Change Password", "Password Never Expires" and "Account Disabled" as required. The actual requirements for these settings will be determined by the polices enforced on each particular installation site.

Select : "Groups".

Confirm that the new user belongs only to the group "Users".

2. Select : "Okay". (twice)

**Note:** *The creation of this user is only for the purpose of starting up the Windows NT workstation operating program. The MAESTRO program will then be started automatically. If this feature is not required, then special additional steps will need to be taken after MAESTRO has been installed.*

This user need not be the same user who will ultimately logon to the MAESTRO system.

3. Select : Start menu / Shut Down / Close all programs and logon as a different user.
4. Logon as "Operator", using the password, which was specified in stage 1. (if any).

# Maestro Graphics System

## Appendix B

### Appendix B2: Changing default configurations

The representation of dates and times can be altered to suit local conventions. By default MAESTRO uses a date format of "dd/mm/yyyy", using a 24 hour clock. This can be changed to another format and a 12 hour clock.

The changes are made via Windows regional settings (Appendix B3).

It is important that the BDE Administrator utility is checked to ensure that the LOCAL SHARE parameter is set to TRUE. To check the parameter, the utility is located in the Start Menu/Programs/(All Users)/Maestro menu. LOCAL SHARE is located under Systems/INIT.

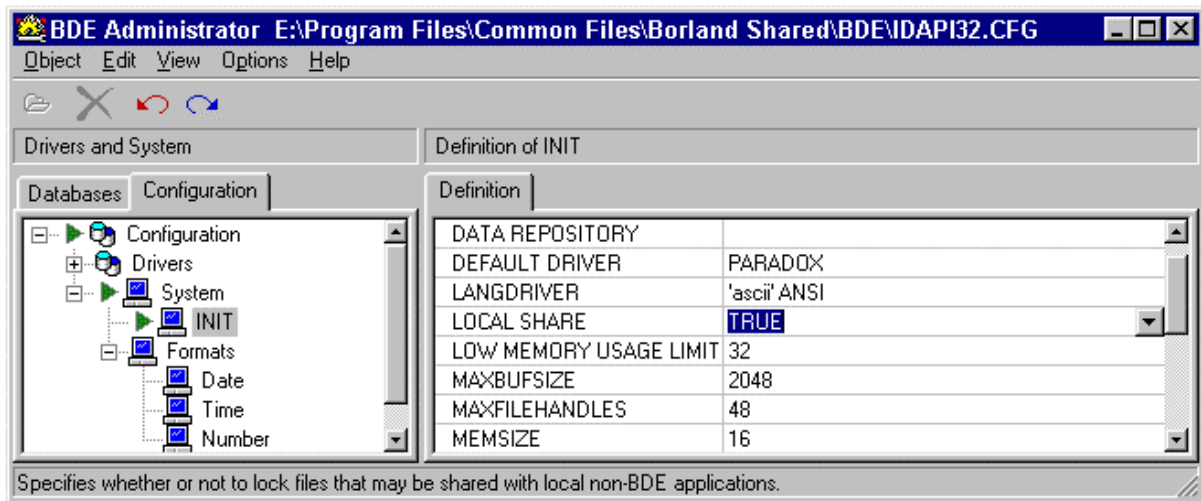

Once all changes to the database configuration have been completed the settings will be applied when the utility is terminated. Any changes made will only become apparent once the MAESTRO application is restarted.

It is strongly advised that no other parameters are changed unless the installer is fully trained and sufficiently knowledgeable to do so, as there may be serious consequences of Fire Detection and Alarm System malfunction due to incorrect or inappropriate database configuration settings.



### Appendix B3: Windows regional settings

#### Windows regional options.

The Windows regional options are set via the Regional Options utility (found in Start Menu/Settings/Control Panel/Regional Options). Variables for example number, time and date formats can be adjusted using the utility.

As there are differences in the utilities option display, both the Windows 2000 and the Windows NT versions are illustrated below.

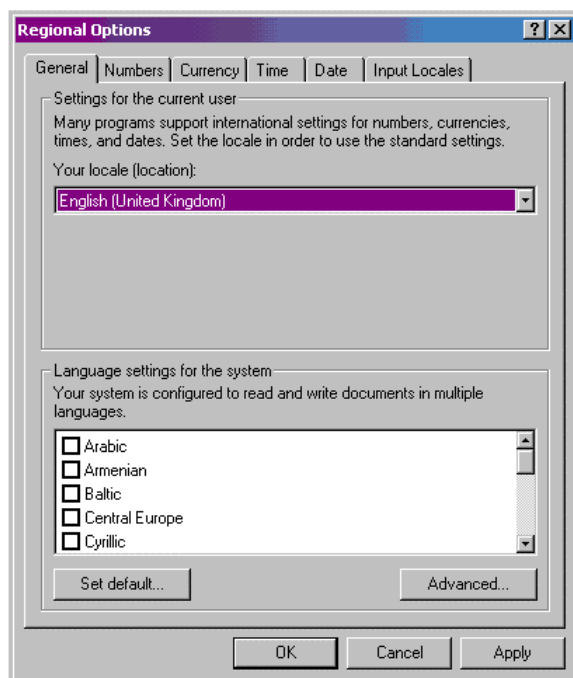

**Windows 2000 Utility**

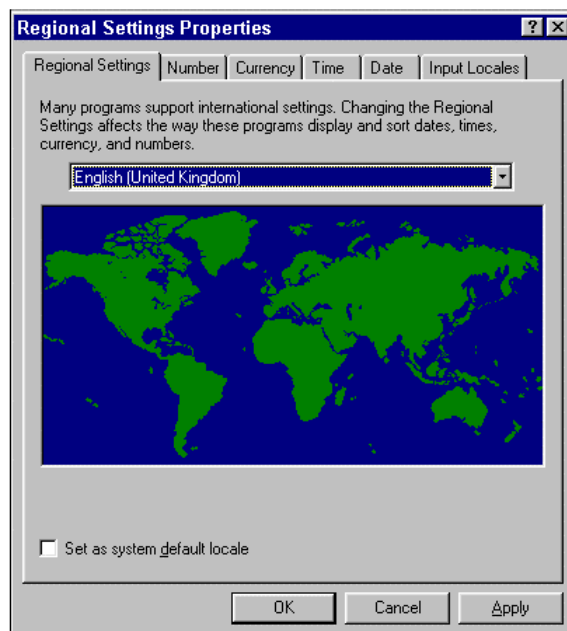

**Windows NT Utility**

MAESTRO will use the System Default settings for date and time, rather than the settings for a particular user. Therefore it is necessary to install the current location as the system default.

The regional default settings are changed by -

1. Launch the Regional Options Utility.
2. Select the Language Locale from the list of available options. e.g. English (United Kingdom).
3. To set this as the Default Locale, Click Set default. Click "OK"

# Maestro Graphics System

## Appendix B

4. Windows will now either request for the Windows CD to be inserted into the appropriate workstation drive, or will display a warning message, informing that the files are already on the system which may be used or be replaced by new ones from the CD. After making a selection, Windows requires the machine to be shut down and restarted for the changes to be made. This happens automatically when the "Yes" option is selected in response to the Shutdown message dialog box.
5. After Windows restarts, logon as Administrator.
6. Launch the Regional Options Utility again.
7. Select the Date tab. Set the Short Date Style to an appropriate style using the format specifiers d for day, M for month and y for year. For example, a setting of "d/mm/yyyy" will specify dates in day month year format with 4 digits for the year.
8. Other regional settings may be changed in a similar manner to the above sequence.
9. Select OK.
10. Windows should not need to be restarted, but if prompted this should be done.